



HESTORE.HU

elektronikai alkatrész áruház

EN: This Datasheet is presented by the manufacturer.

Please visit our website for pricing and availability at www.hestore.hu.



SGS-THOMSON

30E D

GENERAL-PURPOSE SINGLE OP-AMPS

- LARGE INPUT VOLTAGE RANGE
- NO LATCH-UP
- HIGH GAIN
- SHORT-CIRCUIT PROTECTION
- NO FREQUENCY COMPENSATION REQUIRED
- SAME PIN CONFIGURATION AS THE UA709

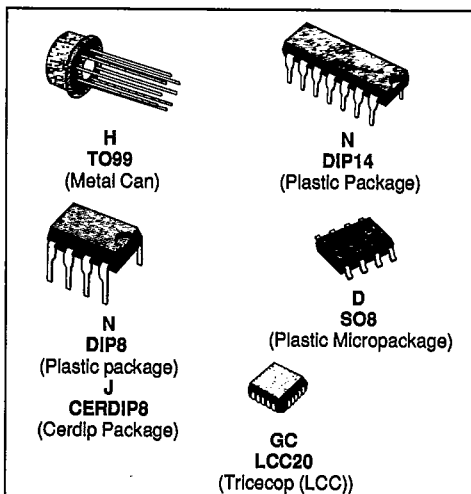

DESCRIPTION

The UA741 is a high performance monolithic operational constructed on a single silicon chip. It is intended for a wide range of analog applications.

- Summing amplifier
- Voltage follower
- Integrator
- Active filter
- Function generator.

The high gain and wide range of operating voltages provides superior performance integrator, summing amplifier, and general feedback applications. the internal compensation network (6 dB/octave) insures stability in closed loop applications.

ORDER CODES

Part Number	Temperature Range	Package					
		H	J	GC	N	N14	D
UA741C/E	0 °C to + 70 °C	•	•		•	•	•
UA741I	-40 °C to + 105 °C	•			•	•	
UA741M/A	-55 °C to + 125 °C	•	•	•			

Note : Hi-Rel Versions Available
Examples : UA741CN, UA741IH

PIN CONNECTIONS (top views)

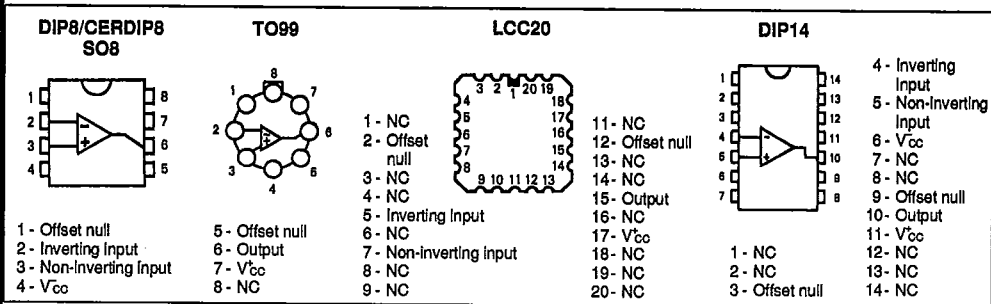

ABSOLUTE MAXIMUM RATINGS S G S-THOMSON

30E D

Symbol	Parameter	Value			Unit
		UA741M, A	UA741I	UA741C, E	
V _{CC}	Supply Voltage	± 22	± 22	± 22	V
V _I	Input Voltage	± 15	± 15	± 15	V
V _{id}	Differential Input Voltage	± 30	± 30	± 30	V
P _{tot}	Power Dissipation	500	500	500	mW
	Output Short-circuit Duration	Infinite			
T _{oper}	Operating Free-air Temperature Range	- 55 to + 125	- 40 to + 105	0 to + 70	°C
T _{stg}	Storage Temperature Range	- 65 to 150	- 65 to 150	- 65 to 150	°C

SCHEMATIC DIAGRAM

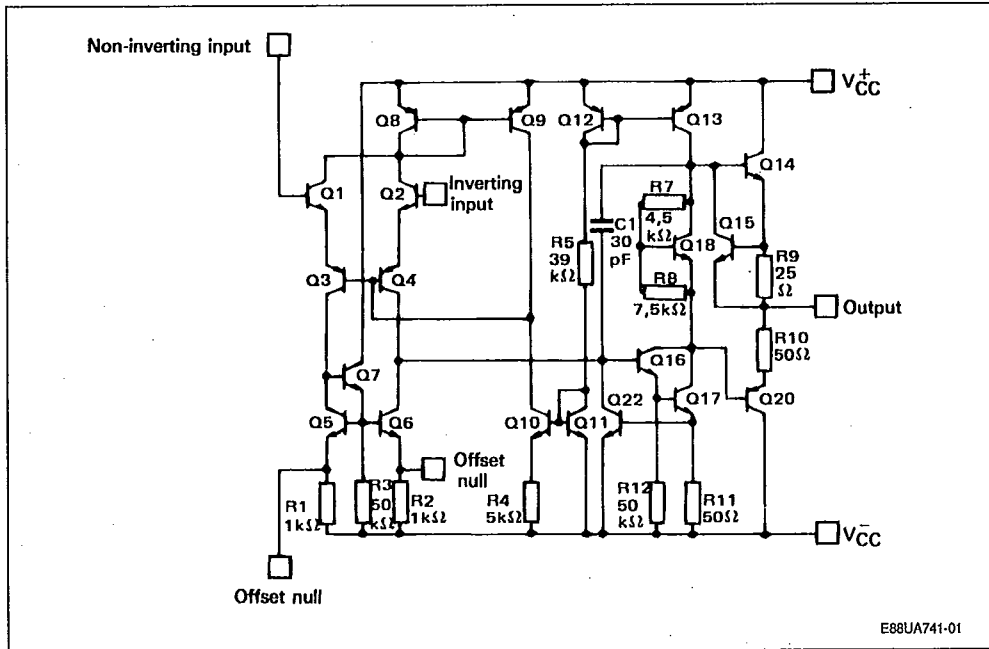

E88UA741-01

Case	Offset Null	Inverting Input	Non-Inverting Input	V _{CC}	V _{CC}	Output	N.C.
TO99/DIP8/CERDIP8/SO8	1, 5	2	3	4	7	6	8
DIP14	3, 9	4	5	6	11	10	*
LCC20	2, 12	5	7	10	17	15	*

* TO116, LCC20 : Other pins are not connected.

ELECTRICAL CHARACTERISTICS S G S-THOMSON

30E D

UA741M/A : -55 °C ≤ T_{amb} ≤ +125 °C, V_{CC} = ±15 VUA741I : -40 °C ≤ T_{amb} ≤ +105 °C, V_{CC} = ±15 VUA741C/E : 0 °C ≤ T_{amb} ≤ +70 °C, V_{CC} = ±15 V

T-79-05-10

(unless otherwise specified)

Symbol	Parameter	UA741C, E, I, M, A			Unit
		Min.	Typ.	Max.	
V _{IO}	Input Offset Voltage R _S ≤ 10 kΩ T _{amb} = 25 °C T _{min} ≤ T _{amb} ≤ T _{max} UA741E, A T _{amb} = 25 °C T _{min} ≤ T _{amb} ≤ T _{max}		1	5 6 2 4	mV
I _{IO}	Input Offset Current T _{amb} = 25 °C T _{min} ≤ T _{amb} ≤ T _{max}		2	20 40	nA
I _B	Input Bias Current T _{amb} = 25 °C T _{min} ≤ T _{amb} ≤ T _{max}		10	100 200	nA
A _{VD}	Large Signal Voltage Gain (V _O = ±10 V, R _L = 2 kΩ) T _{amb} = 25 °C T _{min} ≤ T _{amb} ≤ T _{max}	50 25	200		V/mV
SVR	Supply Voltage Rejection Ratio (R _S ≤ 10 kΩ) T _{amb} = 25 °C T _{min} ≤ T _{amb} ≤ T _{max}	77 77	90		dB
I _{CC}	Supply Current, no Load T _{amb} = 25 °C T _{min} ≤ T _{amb} ≤ T _{max}		1.7	2.8 3.3	mA
V _I	Input Voltage Range T _{amb} = 25 °C T _{min} ≤ T _{amb} ≤ T _{max}	-12 -12		+12 +12	V
CMR	Common Mode Rejection Ratio (R _S ≤ 10 kΩ) T _{amb} = 25 °C T _{min} ≤ T _{amb} ≤ T _{max}	70 70	90		dB
I _{OS}	Output Short-circuit Current T _{amb} = 25 °C	10	25	40	mA
±V _{OPP}	Output Voltage Swing T _{amb} = 25 °C R _L = 10 kΩ R _L = 2 kΩ T _{min} ≤ T _{amb} ≤ T _{max} R _L = 10 kΩ R _L = 2 kΩ	12 10 12 10	14 13		V
S _{VO}	Slew-rate (V _I = ±10 V, R _L = 2 kΩ, C _L ≤ 100 pF, T _{amb} = 25 °C, unity gain)	0.25	0.5		V/μs
t _r	Rise Time (V _I = ±20 mV, R _L = 2 kΩ, C _L ≤ 100 pF, T _{amb} = 25 °C, unity gain)		0.3		μs
K _{OV}	Overshoot (V _I = ±20 mV, R _L = 2 kΩ, C _L ≤ 100 pF, T _{amb} = 25 °C, unity gain)		5		%
R _I	Input Resistance, T _{amb} = 25 °C	0.3	2		mΩ

ELECTRICAL CHARACTERISTICS (continued)

Symbol	Parameter	UA741C, E, I, M, A			Unit
		Min.	Typ.	Max.	
GPB	Gain Bandwidth Product ($V_I = 10\text{ mV}$, $R_L = 2\text{ k}\Omega$, $C_L \leq 100\text{ pF}$, $f = 100\text{ kHz}$, $T_{\text{amb}} = 25\text{ }^\circ\text{C}$)	0.7	1	1.6	MHz
THD	Total Harmonic Distortion ($f = 1\text{ kHz}$, $A_V = 20\text{ dB}$, $R_L = 2\text{ k}\Omega$, $V_O = 2\text{ V}_{pp}$, $C_L \leq 100\text{ pF}$, $T_{\text{amb}} = 25\text{ }^\circ\text{C}$)		0.06		%
V_N	Equivalent Input Noise Voltage ($f = 1\text{ kHz}$, $R_G = 100\text{ }\Omega$)		23		$\text{nV}/\sqrt{\text{Hz}}$
	Phase Margin		50		Degrees

SGS-THOMSON

OPEN LOOP VOLTAGE GAIN (Typ.)

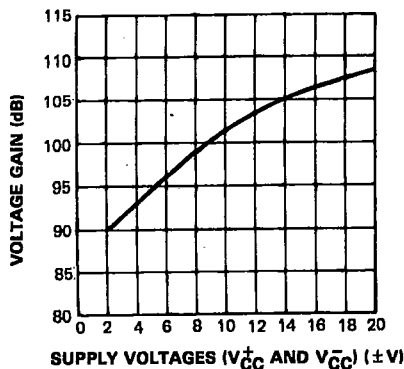

E88UA741-02

30E D

OPEN LOOP FREQUENCY RESPONSE (Typ.)

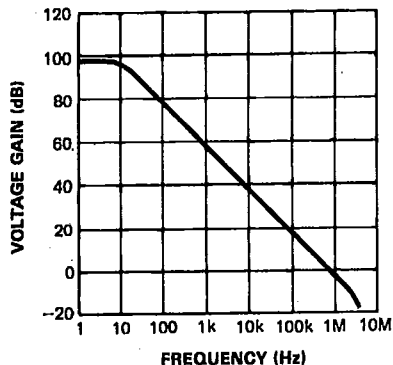

E88UA741-03

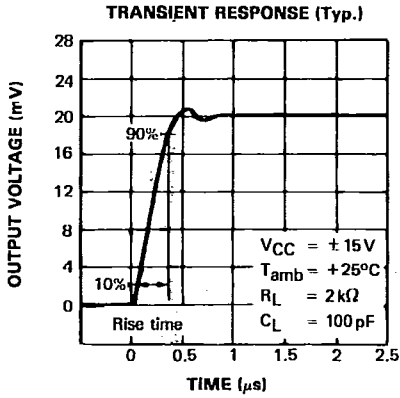

E88UA741-04

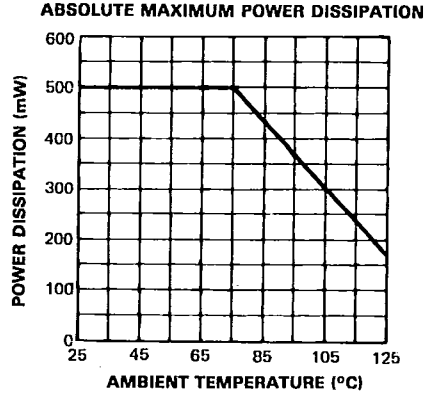

E88UA741-05

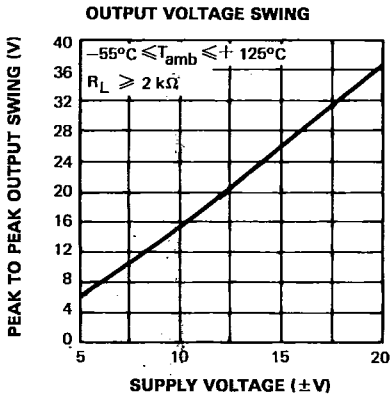

E88UA741-06

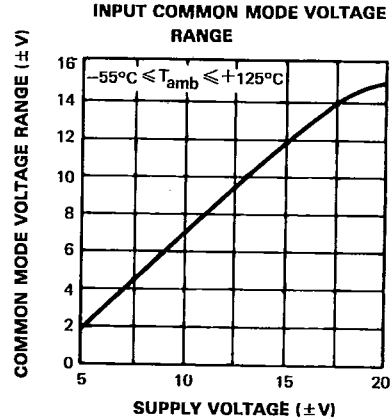

E88UA741-07

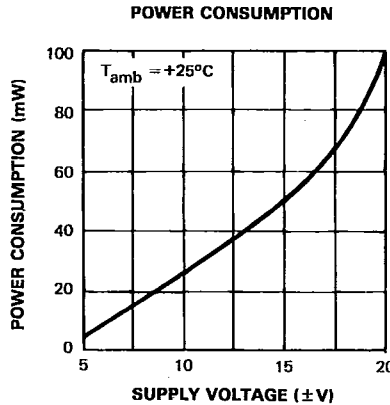

E88UA741-08

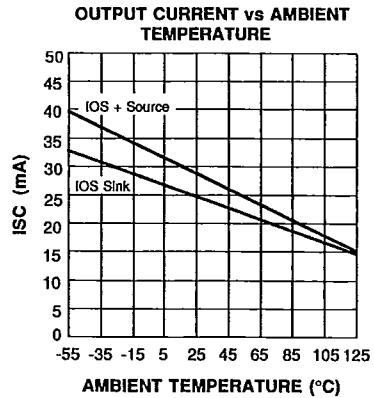

E88UA741-09

SGS-THOMSON

30E D



OUTPUT VOLTAGE SWING

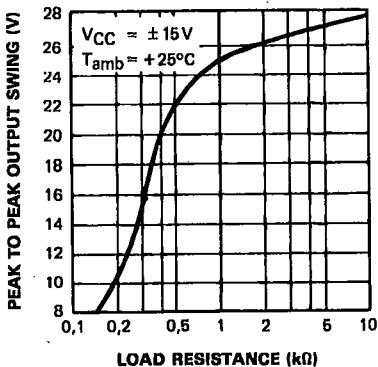

E88UA741-10

OUTPUT VOLTAGE SWING

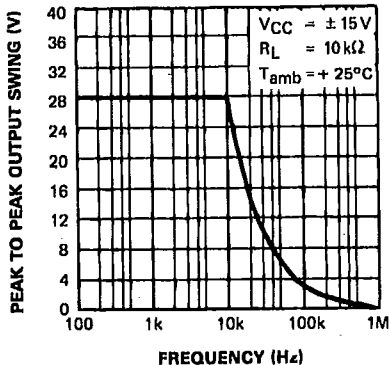

E88UA741-11

EQUIVALENT INPUT NOISE vs FREQUENCY
 $R_g = 100 \Omega$

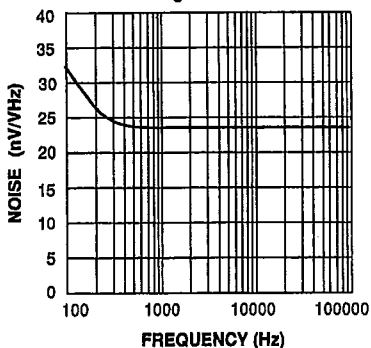

E88UA741-12

INPUT NOISE CURRENT

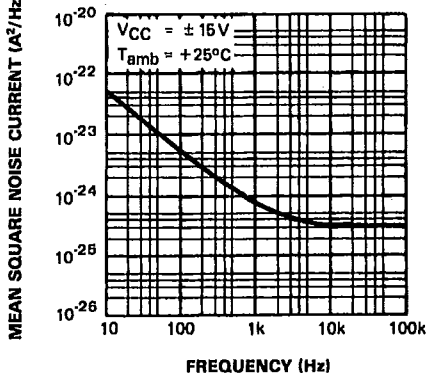

E88UA741-13

EQUIVALENT INPUT NOISE vs AMBIENT TEMPERATURE

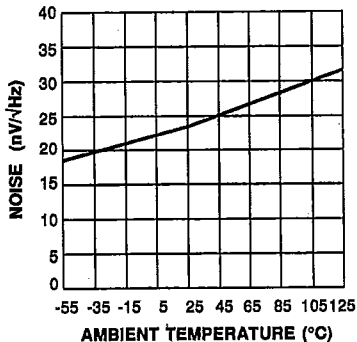

E88UA741-14

LARGE SIGNAL VOLTAGE GAIN vs AMBIENT TEMPERATURE

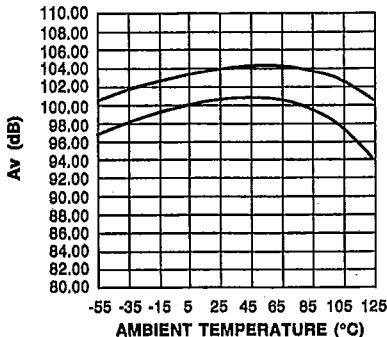

E88UA741-15

SGS-THOMSON

30E D

GAIN BANDWIDTH PRODUCT vs AMBIENT TEMPERATURE

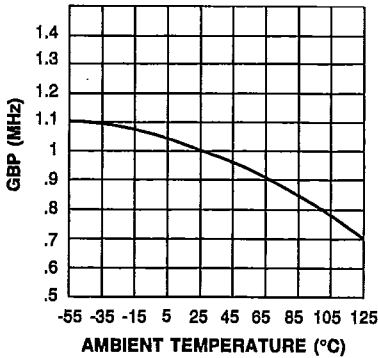

E88UA741-16

POWER SUPPLY & COMMON MODE REJECTION RATIO vs AMBIENT TEMPERATURE

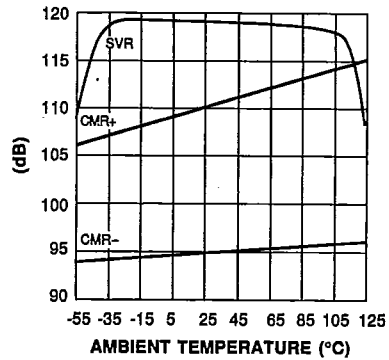

E88UA741-17

INPUT BIAS CURRENT vs AMBIENT TEMPERATURE

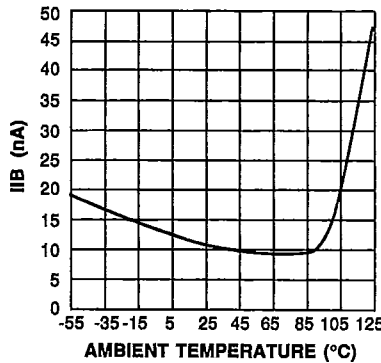

E88UA741-18

MEASUREMENT DIAGRAMS

SGS-THOMSON

30E D

VOLTAGE OFFSET NULL CIRCUIT

TRANSIENT RESPONSE TEST CIRCUIT

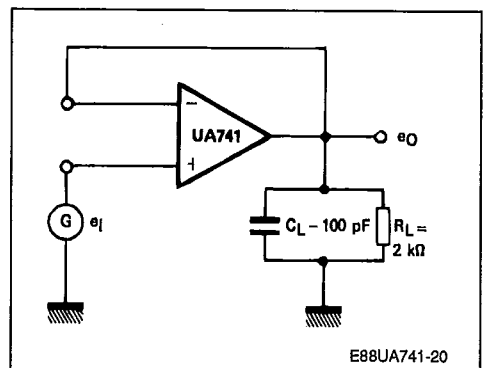
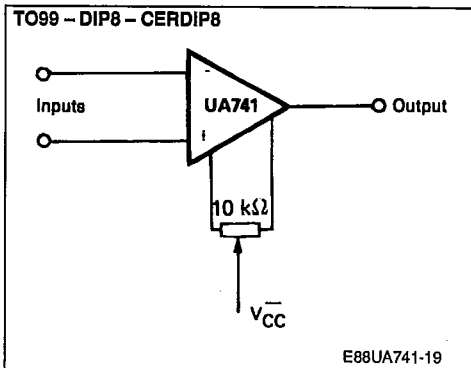

MEASUREMENT DIAGRAMS (continued)

CURRENT TO VOLTAGE CONVERTER

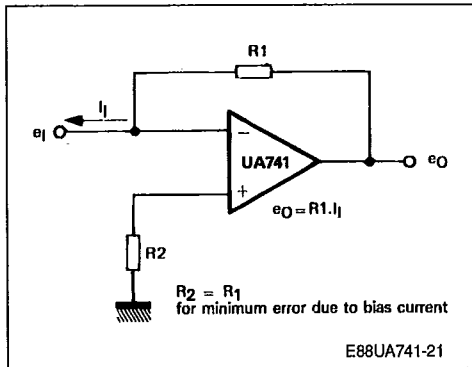

NEUTRALIZING INPUT CAPACITANCE TO OPTIMIZE RESPONSE TIME

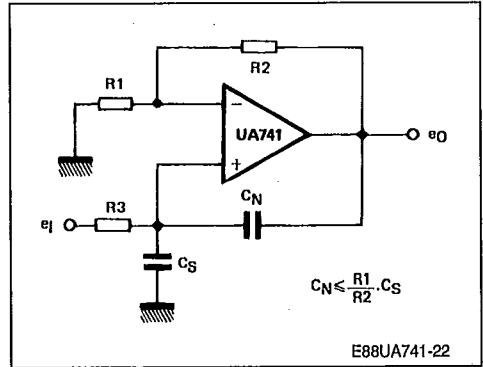

POSITIVE VOLTAGE REFERENCE

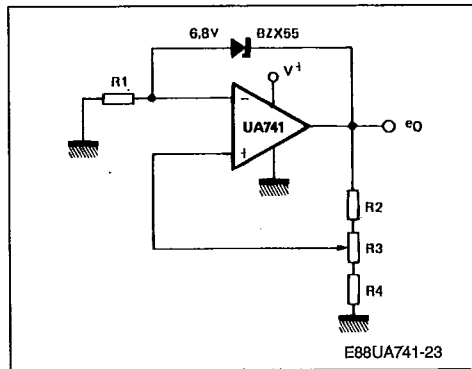

NEGATIVE VOLTAGE REFERENCE

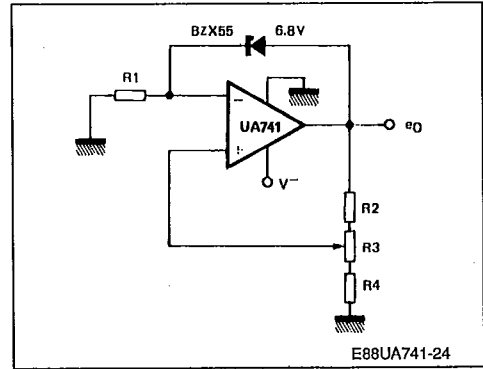

S G S-THOMSON

30E D

PACKAGE MECHANICAL DATA

S G S-THOMSON

30E D

8 PINS - TO99 - METAL CAN

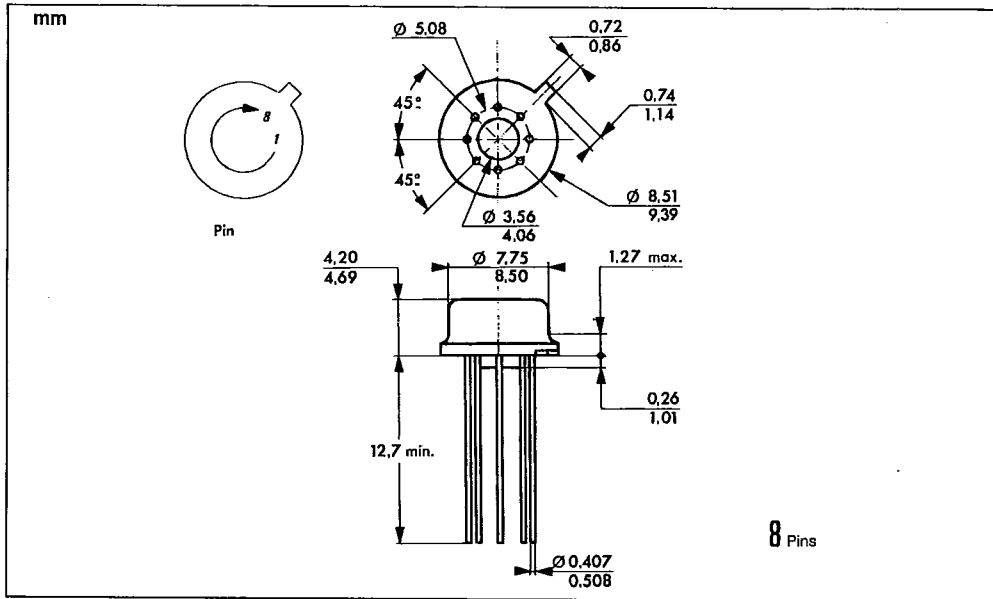

14 PINS - PLASTIC DIP

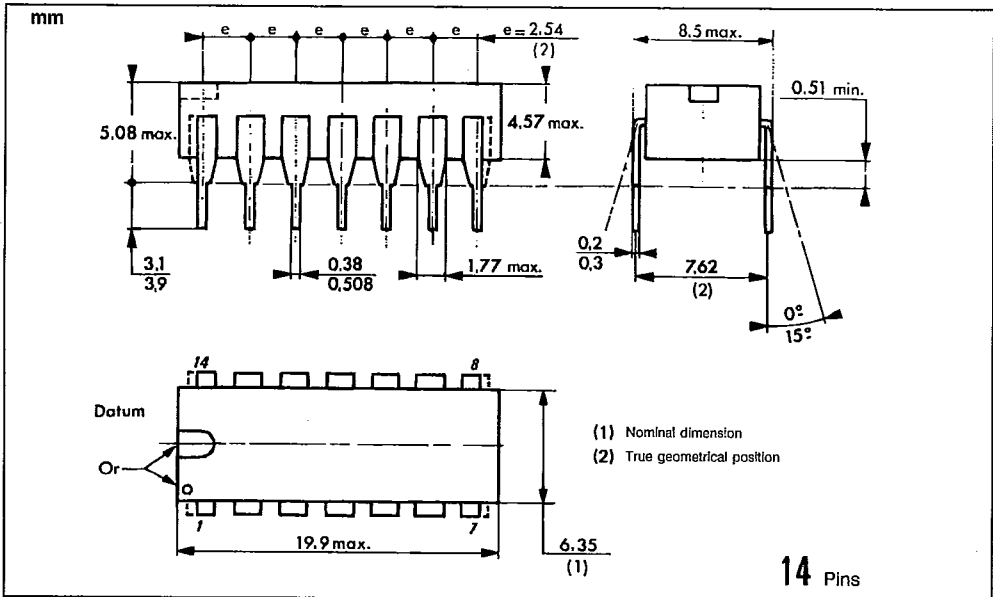

PACKAGE MECHANICAL DATA (continued)

8 PINS - PLASTIC DIP OR CERDIP S G S-THOMSON

30E D

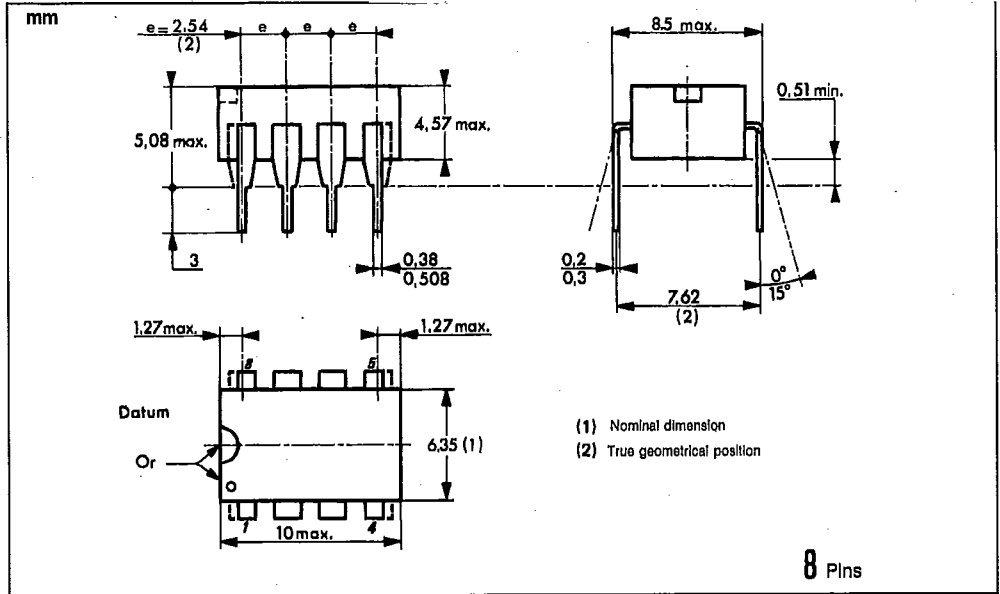

20 PINS - TRICECOP (LOC)

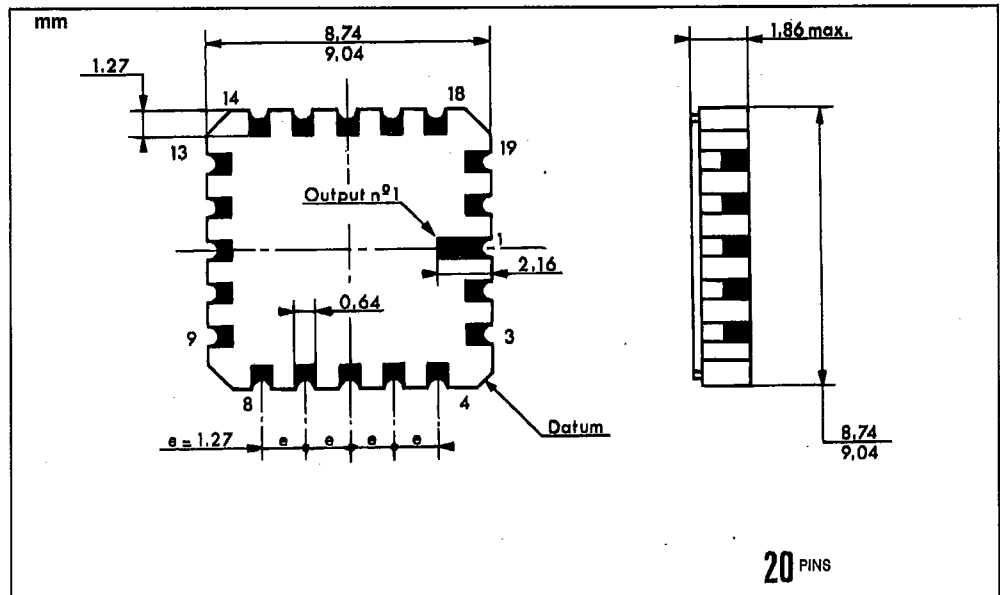

PACKAGE MECHANICAL DATA (continued)

8 PINS - PLASTIC MICROPACKAGE (SO) S G S-THOMSON

30E D

