



HESTORE.HU

elektronikai alkatrész áruház

EN: This Datasheet is presented by the manufacturer.

Please visit our website for pricing and availability at www.hestore.hu.



SIDE VIEW OF BOX

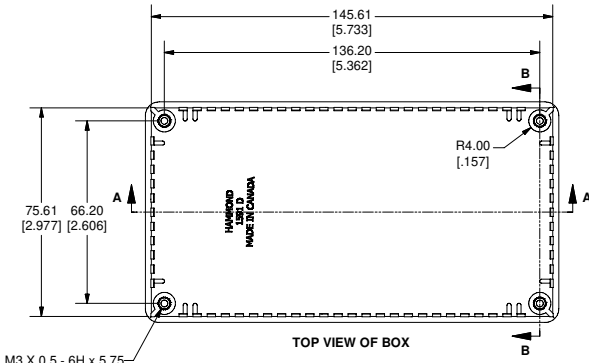

TOP VIEW OF BOX

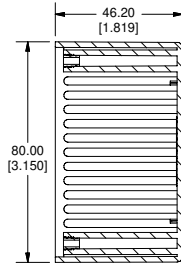

SECTION B-B

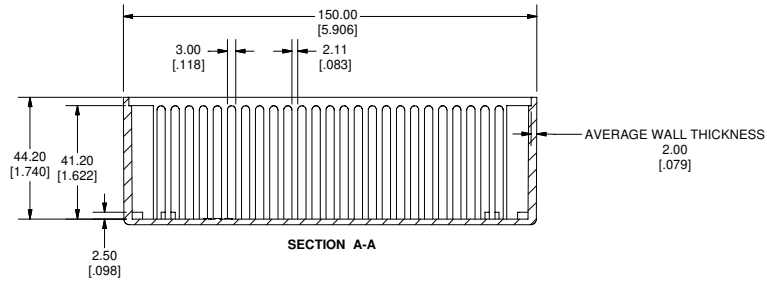

SECTION A-A

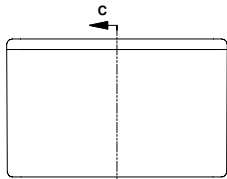

END VIEW OF ASSEMBLY

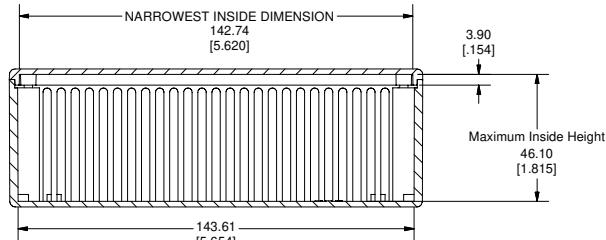

SECTION C-C

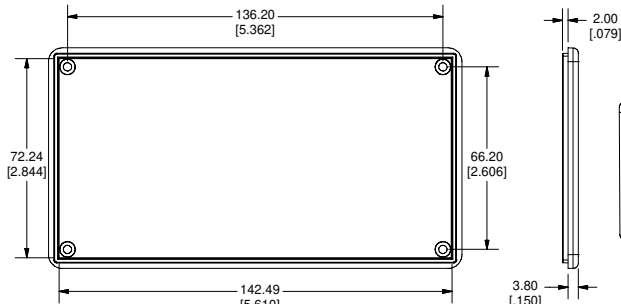

BOTTOM ON LID

SIDE OF LID

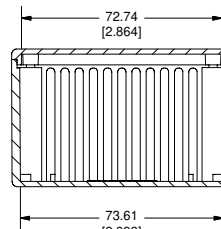
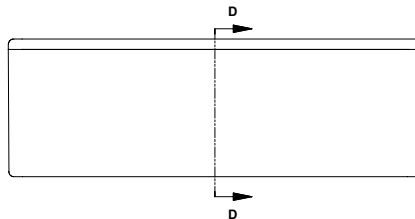

SECTION D-D

Note:
Enclosures can be Factory Modified (Milling, Drilling, Printing etc.)
Contact Factory mjm@hammondmfg.com for quotes
Solid models of this enclosure available in STEP or IGES Format.

PART NUMBERS		
1591D Enclosures		
Material	Colour	Part Number
FR ABS	Beige	1591DBG
	Black	1591DBK
	Blue	1591DBU
UL94 - V0	Grey	1591DGY
	Black RAL 9011	1591DSBK
GP ABS	Grey RAL7035	1591DSGY
	Ice Blue	1591DTBU
Translucent Polycarbonate	IR Red	1591DTRD
	Crystal Clear	1591DTCL
Accessories		
	Description	Part Number
Universal Use	PC Board Card Adapters	See Accessories Section
	Clear Lids - clear, flame retardant polycarbonate - Lid ONLY	1591DC
FR ABS	Replacement Screws, Flat Head Phillips	1591MS100
	Nickel Plated Pkg of 100	1591TS100 (Black)
GP ABS	Self Tapping Pkg of 100	1591TS100
		1591TS100BK (Black)
Recommended Torque on Fasteners (no lubrication)		
	M3 - 0.5 x 10mm Screws	30-40 cN*m
	#4 x 0.5 Screws	30-40 cN*m

