



**HESTORE.HU**

elektronikai alkatrész áruház

**EN:** This Datasheet is presented by the manufacturer.

Please visit our website for pricing and availability at [www.hestore.hu](http://www.hestore.hu).

## General Description

QX5305 is a high efficient boost type LED driver IC. It is especially suited to drive several high power and high luminance LEDs in series.

QX5305 uses fixed off-time control scheme, and 1MHz switching frequency can be achieved.

QX5305 set the off-time by an external capacitor, the minimum off-time is 620ns and the off-time can be adjusted by changing the external capacitor, and the operating frequency also can be adjusted according to the need of customers.

QX5305 regulates the current flowing through LEDs to set the luminance of LEDs by changing the external resistor, on the other hand, the luminance of LEDs also can be regulated by a PWM signal applied to EN pin.

## Features

- High Efficiency: up to 95%
- Switching Frequency: up to 1MHz
- Wide Range Input Voltage: 3.6V to 100V
- UVLO Voltage: 2.5V
- Peak Current Sense Voltage: 250mV
- Adjustable Luminance With PWM Signal Applied to EN Pin
- Adjustable Off-time
- Internal Current Sampling Leading Edge Blanking Circuit

## Applications

- Battery-powered LED lights
- Flat panel display LED backlight
- Constant current charger control
- Power LED lighting

## Typical Application

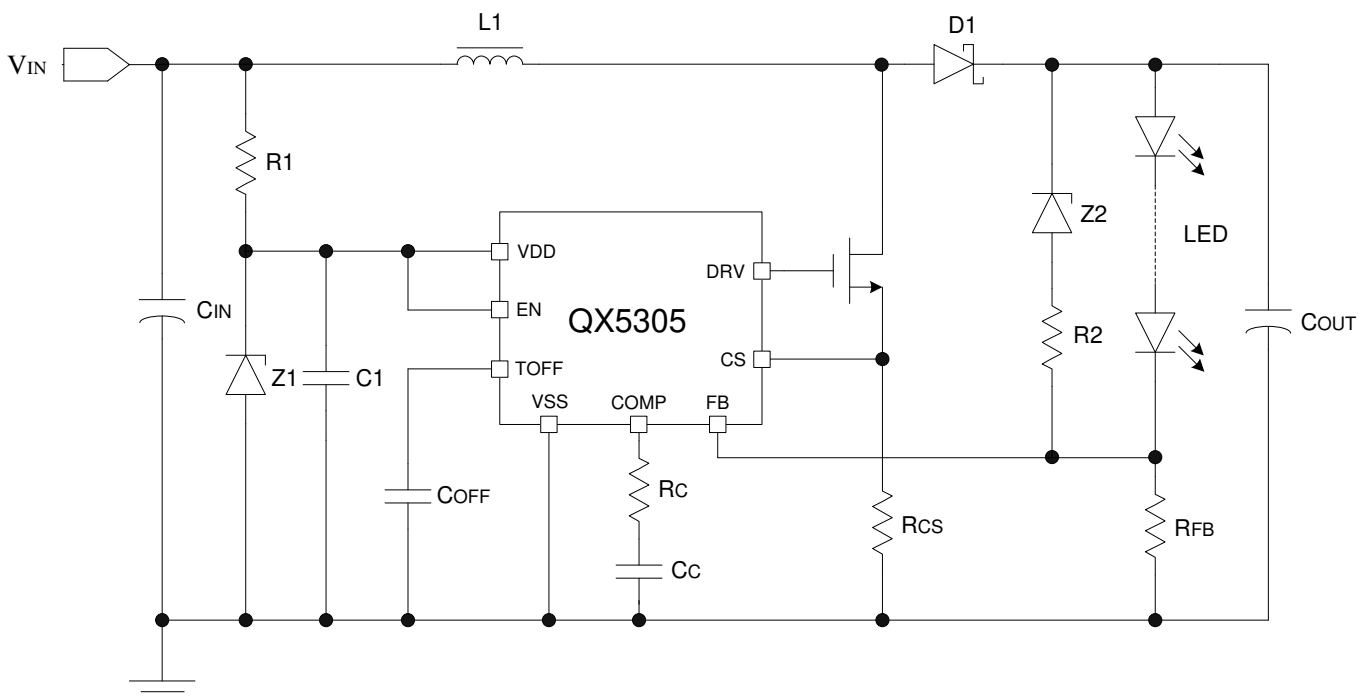

Figure 1: Typical Application Circuit Diagrams of QX5305

## Ordering Information

Type Number

# QX5305

## Package Marking

5305  
XXXX

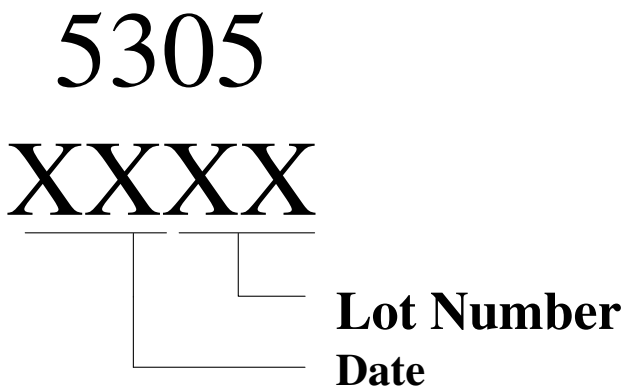

Lot Number  
Date

## Pin Assignments

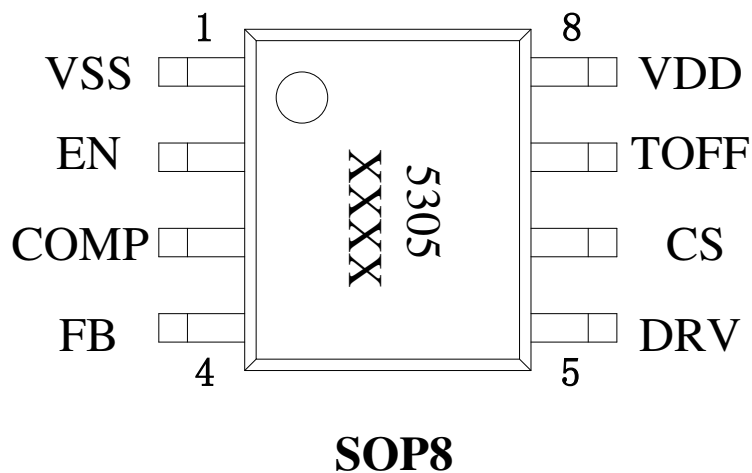

## Pin Description

Pin	Pin Name	Pin Type	Description
1	VSS	Ground	Chip Ground Pin
2	EN	Input	Chip Enable Pin (Active High)
3	COMP	Output	Compensation
4	FB	Input	Voltage Feedback pin
5	DRV	Output	Driver pin
6	CS	Input	Current sense
7	TOFF	Input	Off time set pin
8	VDD	Power	Chip Power Pin

## Functional Block Diagram

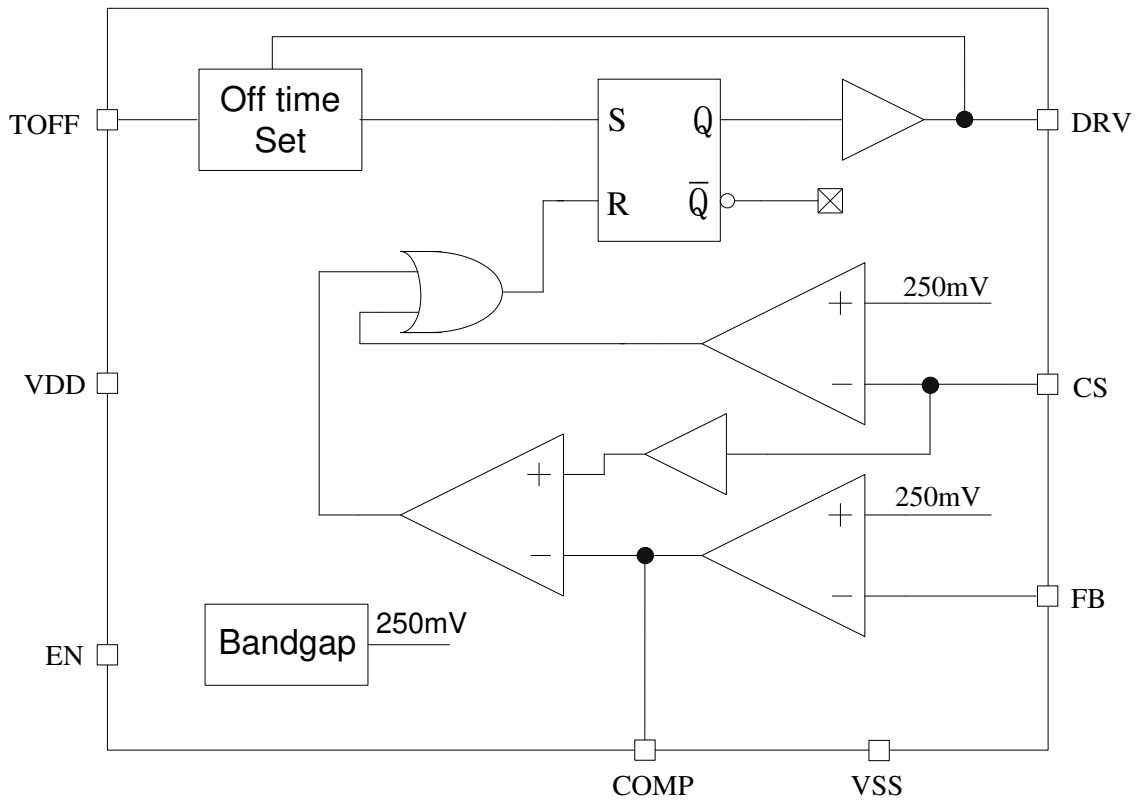

Figure 2: Functional Block Diagram of QX5305

## Absolute Maximum Ratings (Note 1)

Parameter	Symbol	Description	Min	Max	Unit
Voltage	V <sub>MAX</sub>	Maximum Voltage On VDD Pins		7	V
	V <sub>MIN_MAX</sub>	The Voltage On EN,COMP,FB,DRV,CS and TOFF Pin	-0.3	V <sub>DD</sub> +0.3	V
Power Dissipation	P <sub>SOP8</sub>	Maximum Power Dissipation for P <sub>SOP8</sub> Package		0.75	W
Thermal	T <sub>J</sub>	Junction Temperature Range	-20	125	°C
	T <sub>A</sub>	Operating Temperature Range	-20	85	°C
	T <sub>STG</sub>	Storage Temperature Range	-40	120	°C
	T <sub>SD</sub>	Soldering Temperature Rang (less than 30 sec)	230	240	°C
ESD	V <sub>ESD</sub>	ESD Voltage for Human Body Mode		2000	V

Note 1: Absolute Maximum Ratings indicate limits beyond which damage to the device may occur. Exposure to Absolute Maximum Rating conditions for extended periods may affect device reliability.

## Recommended Operating Conditions (Note 2)

Parameter	Symbol	Min	Typ	Max	Unit
VDD Voltage	V <sub>DD</sub>	2.5	5	5.5	V
OSC frequency	F <sub>OP</sub>	20	200	1000	KHz

Note 2: The Recommended Operating Conditions are required in order to ensure the normal operation of the IC, but does not guarantee completely meeting the individual performance characteristics.

## Electronic Characteristics

$T_A = 25^\circ\text{C}$ ,  $V_{DD} = 5\text{V}$ , unless otherwise specified

Parameter	Symbol	Test Conditions	Min	Typ	Max	Unit
<b>Supply Voltage</b>						
Maximum Input Voltage	$V_{IN\_MAX}$			5	6	V
UVLO Voltage	$V_{UVLO}$	$V_{DD}$ rises from 0V		2.5		V
<b>Supply Current</b>						
Current Limiting	$I_{OP}$	FOP = 200KHz		1.3		mA
Standby Input Current	$I_{INQ}$	Without Load, EN = "Low"		220		uA
<b>MOSFET Parameters</b>						
Over current threshold	$V_{CS\_TH}$		240	250	260	mV
Shut down delay	$T_D$			61		ns
<b>DRV Time</b>						
DRV rise time	$T_{RISE}$	DRV connect a 500pF capacitor			50	ns
DRV fall time	$T_{FALL}$	DRV connect a 500pF capacitor			50	ns
<b>Output Current Sense</b>						
FB Pin Voltage	$V_{FB}$		240	250	260	mV
<b>T-Off Time</b>						
Minimum Off Time	$T_{OFF\_MIN}$	TOFF without capacity		620		ns
<b>Enable Input On EN Pin</b>						
"High" Voltage Level On EN Pin			$0.4 \times V_{DD}$			V
"Low" Voltage Level On EN Pin					0.8	V
<b>OSC</b>						
Maximum frequency	$F_{MAX}$				1000	KHz

## Typical Electrical Curves

$V_{IN} = 5V$ ,  $T_A = 25^\circ C$ , unless otherwise specified

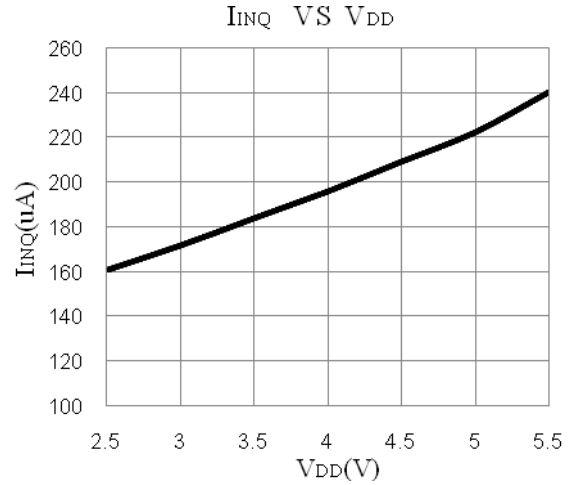
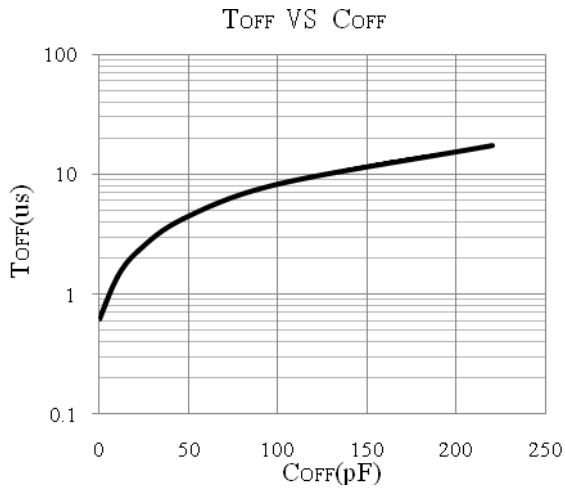

## Applications Information

### Detailed Description

QX5305 is a highly efficient constant current driver for high luminance LED with built-in high accuracy comparator, fixed off-time controller and constant current driver etc.

QX5305 uses fixed off-time and peak current control mode, and the system of circuit operates with a switching transistor in the turn-on or turn-off states.

QX5305 works in two states, that is, ON State and OFF State. In ON State, the external switch is on until one of the comparators outputs a high level voltage, QX5305 goes to OFF state. In OFF State, the external switch remains off until a fixed off time and the outputs of the two comparators are low, QX5305 goes to ON state and repeat the ON and OFF process.

QX5305 works like a traditional current mode PWM DC-DC converter except that the off time is fixed and the working frequency is variable due to the values of VIN and VOUT. The comparator connected to CS pin is used for current limiting and the comparator connected to FB is used for voltage feedback.

### T<sub>OFF</sub> Setting

The fixed off-time T<sub>OFF</sub> is determined by the capacitor C<sub>OFF</sub> connected to the pin T<sub>OFF</sub>:

$$T_{OFF} = 0.51 * 150K\Omega * (C_{OFF} + 7.3pF) + T_D$$

where T<sub>D</sub> equals 61ns. If T<sub>OFF</sub> pin is left open, the typical value of T<sub>OFF</sub> is 620us.

### Output Current Setting

The LED current is determined by the formula below:

$$I_{LED} = \frac{0.25}{R_{FB}}$$

where R<sub>FB</sub> is the feedback resistance.

### R<sub>CS</sub> Setting

R<sub>CS</sub> should be set reasonable to prevent the input current is limited on normal load conditions, R<sub>CS</sub> is determined by the formula below:

$$V_{IN} \times I_{IN} \times \eta = V_{OUT} \times I_{LED}$$

$$I_{IN} = \frac{V_{CS}}{R_{CS}} - \frac{\Delta I_L}{2}$$

$$I_{IN} = \frac{V_{CS}}{R_{CS}} - \frac{V_{LED} - V_{IN}}{2L} \times T_{OFF}$$

R<sub>CS</sub> should be less than the theoretical value in practical applications.

### Inductor Selection

To ensure the system output constant current, the inductor must operate in CCM mode, the minimum inductance needed is

$$L_{critical} > \frac{V_{IN} * (V_{OUT} - V_{IN}) * T_{OFF}}{2V_{OUT} * I_{LED}}$$

### Operating Frequency of System

The operating frequency of system is determined by the formula below:

$$F_S = \frac{V_{IN}}{V_{OUT} * T_{OFF}}$$

### MOS Selection

The MOS withstand voltage requires more than 1.5 times the maximum output voltage. And the MOS should be selected according to the LED current and maximum peak inductor current, the maximum I<sub>DS</sub> should be more than 2 times the maximum peak inductor current. In addition, chip operating voltage determines the DRV drive voltage, typical chip drive voltage is 5V, it should ensure that the MOS conduction resistance is low enough.



## Package Information

Physical Dimensions for SOP8 Package:

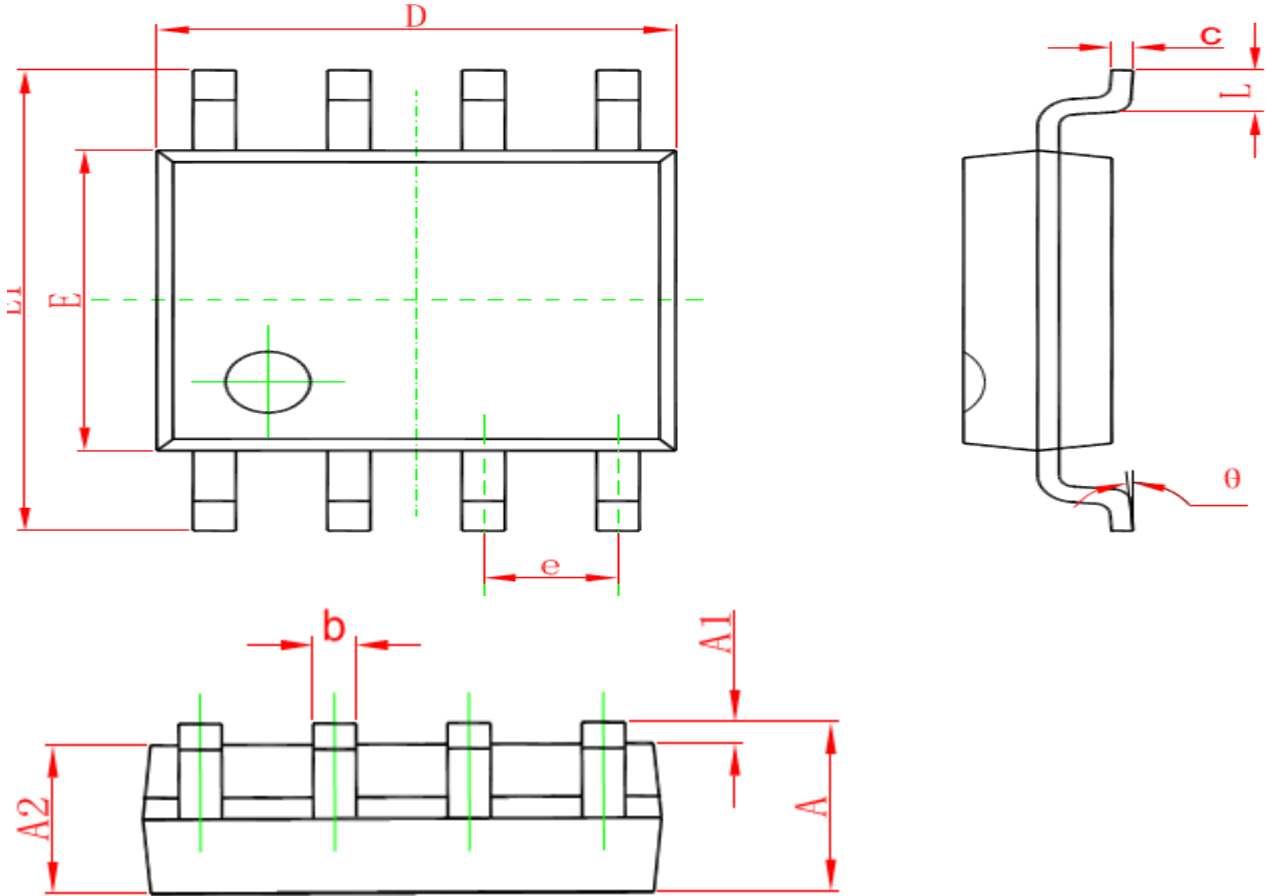

Symbol	Dimensions In Millimeters		Dimensions In Inches	
	Min	Max	Min	Max
A	1.350	1.750	0.053	0.069
A1	0.100	0.250	0.004	0.010
A2	1.350	1.550	0.053	0.061
b	0.330	0.510	0.013	0.020
c	0.170	0.250	0.006	0.010
D	4.700	5.100	0.185	0.200
E	3.800	4.000	0.150	0.157
E1	5.800	6.200	0.228	0.244
e	1.270 (BSC)		0.050 (BSC)	
L	0.400	1.270	0.016	0.050
θ	0°	8°	0°	8°

## Declaration

- QXMD reserves the right to make changes to improve technical design and semiconductor products, and may do so without further notice. Buyers should obtain the latest relevant information before placing orders and should verify that such information is current and complete.
- QXMD is continually working to improve the quality and reliability of its products. Nevertheless, semiconductor devices in general can malfunction or fail due to their inherent electrical sensitivity and vulnerability to physical stress. It is the responsibility of the buyers, when utilizing QXMD products, to comply with the standards of safety in making a safe design for the entire system, and to avoid situations in which a malfunction or failure of such QXMD products could cause loss of human life, bodily injury or damage to property.

In developing your designs, please ensure that QXMD products are used within specified operating ranges as set forth in the most recent QXMD products specifications.

- The QXMD products listed in this document are intended for usage in consumer electronics applications. These QXMD products are neither intended nor warranted for usage in equipment that requires extraordinarily high quality and/or reliability or a malfunction or failure of which may cause loss of human life or bodily injury (“Unintended Usage”). Unintended Usage include atomic energy control instruments, airplane or spaceship instruments, transportation instruments, traffic signal instruments, combustion control instruments, medical instruments, all types of safety devices, etc.. Unintended Usage of QXMD products listed in this document shall be made at the customer’s own risk.
- The information contained herein is presented only as a guide for the applications of our products. QXMD cannot assume responsibility for use of any circuitry other than circuitry entirely embodied in a QXMD product. No circuit patent licenses are implied.

## Customer Service Center

QX Micro Devices Co., Ltd.

Add: 4th Floor, Building 22, Zhiheng Hi-Tech Park, Nantou Guangkou 2nd Road, Nanshan, Shenzhen, Guangdong, China

ZIP Code: 518052

Tel: +86-0755-88852177

Fax: +86-0755-86350858

Web Site: [www.qxmd.com.cn](http://www.qxmd.com.cn)