



**HESTORE.HU**

elektronikai alkatrész áruház

**EN:** This Datasheet is presented by the manufacturer.

Please visit our website for pricing and availability at [www.hestore.hu](http://www.hestore.hu).



**Extractor Tool  
Instruction Sheet  
Order No. 11-03-0043  
Engineering No. HT60923A**

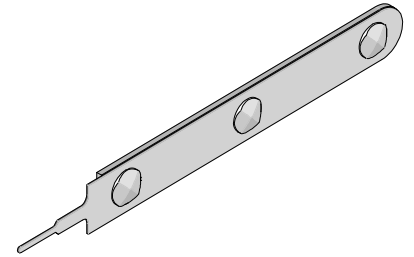

**FEATURES**

- This tool is designed to extract many different terminal series from various plug and receptacle housings. See Chart below.

**SCOPE**

Products:

Terminal Series No.	Description	Housings Series No.	Terminal Order No.				
43030	Micro-Fit 3.0™ Crimp Terminal 20-24 AWG	43025 43645 44133	43030-0001	43030-0002	43030-0003	43030-0004	43030-0005
			43030-0006	43030-0007	43030-0008	43030-0009	43030-0010
			43030-0011	43030-0012	43030-0051	43030-0052	43030-0053
			43030-0056	43030-0057	43030-0058	43030-0059	43030-0080
			43030-0081	43030-1001			
43031		43020 43640 44300	43031-0001	43031-0002	43031-0003	43031-0004	43031-0005
			43031-0006	43031-0007	43031-0008	43031-0009	43031-0010
			43031-0011	43031-0012	43031-0016	43031-0017	43031-0018
			43031-0019	43031-0051	430310052	430310053	43031-0057
			43031-0059	43031-0102	43031-0103	43031-0106	
44372	Micro-Fit 3.0™ High Force Crimp Terminal 20-24 AWG	43025 43645 44133	44372-0002				
46235	Micro-Fit 3.0™ Crimp Terminal 20-24 AWG	43025 43645 44133	46235-0001	46235-0002	46235-0003	46235-0004	
50011	2.0mm (.079") Low Profile Receptacle Terminal 24-34 AWG	51004 51049	50011-8000	50011-8100	39-00-0422		
50031		51004 51049	50031-8000	50031-8100			
50058	1.25mm (.049") Pitch PicoBlade™ Crimp Terminal 26-32 AWG	51021	50058-8000	50058-8099	50058-8100	50058-8200	50058-8300
50061	1.25mm (.049") Pitch Board-In Crimp Terminal 28-32 AWG	51022	50061-8000	50061-8018	50061-8028	50061-8099	50061-8100
			50061-8118	50061-8128			
50079	1.25mm (.049") Pitch PicoBlade™ Crimp Terminal 26-28 AWG	51021	50079-8000	50079-8053	50079-8099	50079-8100	50079-8153
50080			39-00-0413	39-00-0414			
50125			51022	50080-8000	50080-8100		
50133	1.25mm (.049") Pitch PicoBlade™ Crimp Terminal 28-32 AWG	51047	50133-8000	50133-8100			
50147	2.50mm (.098") Pitch Splash Proof Crimp Terminal 20-22 AWG	52266	50147-8000	50147-8100			
50148		52213	50148-8000	50148-8100			

Terminal Series No.	Description	Housings Series No.	Terminal Order No.				
50200	2.0mm (.079") Low Profile Receptacle Terminal 22-32 AWG	51004 51049	50200-8000	50200-8100			
50212	Micro-Latch™ 2.00mm (.079") Pitch Crimp Terminal 24-30 AWG	5109 51065 51090	50212-8000	50212-8100	50212-8200	50212-8300	39-00-0424
50372	2.00mm (.079") Pitch Crimp Terminal 22-26 AWG	5109 51065 51090	50372-8000	50372-8100			
50420	4.00mm (.157") Pitch OBD-II Wire-to-Wire Crimp Terminal	51115 51116	50420-8000	50420-8100	50420-8200		
502438	2.00mm (.079") Pitch CLIK-Mate™ Wire-to-Board Crimp Terminal, 22-26 AWG	502443 502494	502438-0000	502438-0100			

Note: All Individual terminals may be extracted from the housing using this Tool.

**OPERATION:**

**For 43030, 43031, 44372, and 46235 Terminal Series:**

1. Insert the tip of the tool on either side of the terminal until it stops. See Figure 1.
2. Rotate tool clockwise then counter-clockwise approximately 25° to 30° in each direction, once or twice.
3. Repeat steps 1 and 2 on the opposite side of terminal.
4. Pull on the wire and remove the terminal from the housing. See Figure 2.

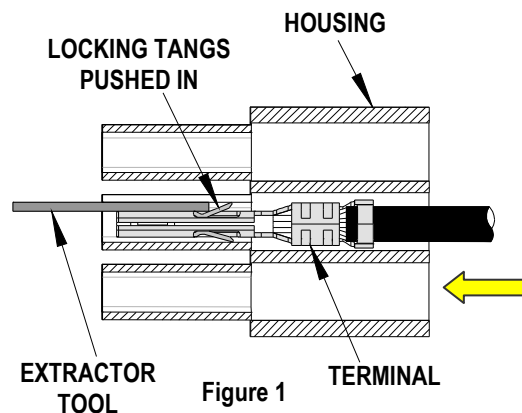

Figure 1

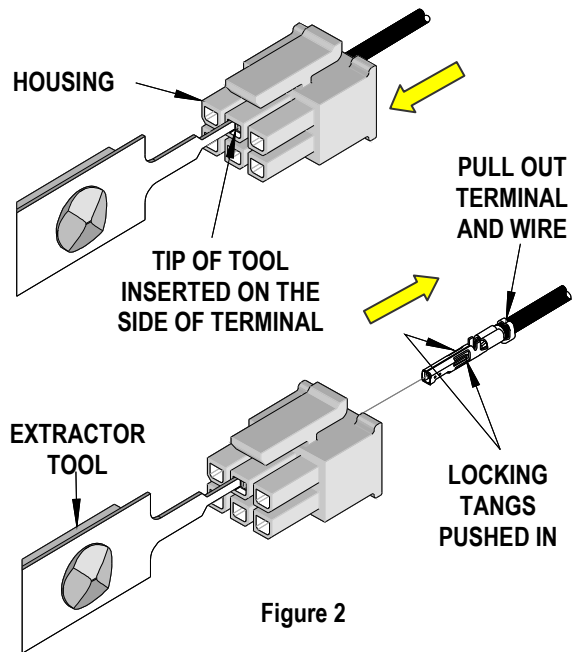

Figure 2

**NOTE:** When a terminal is removed in this manner the locking tangs are damaged and the terminal is not reusable.

**For 50011, 50031, 50058, 50061, 50079, 50080, 50125, 50133, 50200, 50212 and 50372 Terminal Series:**

1. Hold the housing with the locking tang facing up. Bend the wire down and insert the tip of the tool into the housing under the locking tang. See Figure 3.
2. Hold the wire against the extractor tool and pull out the wire and the extractor tool at the same time. See Figure 4.

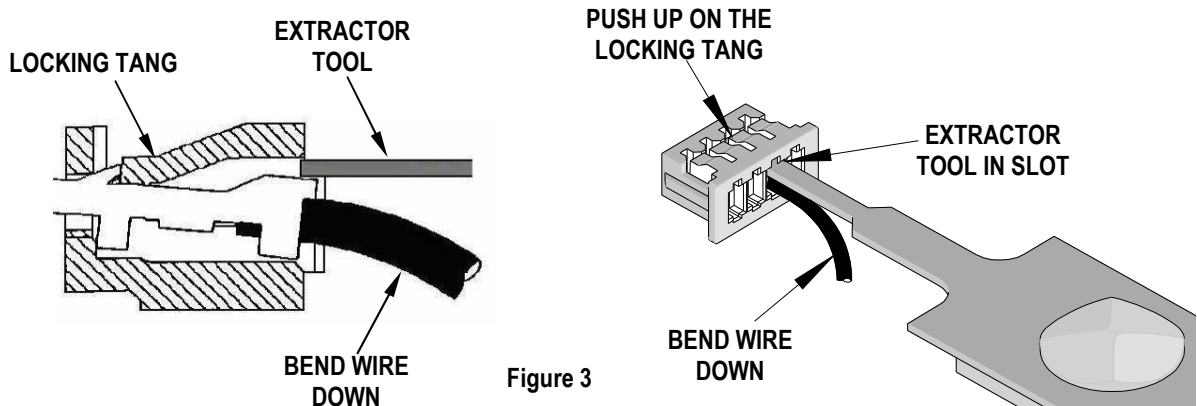

Figure 3

**NOTE:** When re-using the housing remember to bend back the locking tang when inserting another terminal.

**For 50147 and 50148 Terminal Series:**

1. For terminal series 50147, push the terminal forward in the arrow direction before using the Extractor Tool.
2. Insert the tip of the Extractor Tool on an angle above the terminal into the slot on the top of the connector housing.
3. While rotating the extraction tool down, bend the terminal locking tang down and push the terminal back through the connector slot. Make sure that the terminated wire is pulled out at the same time. See Figure 5.

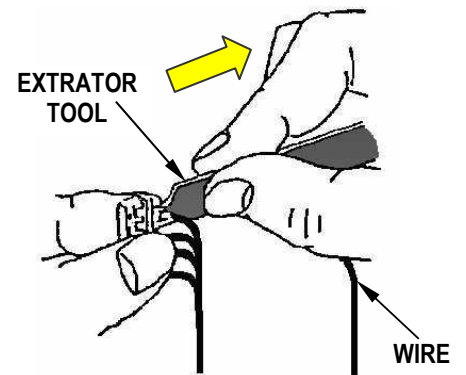

Figure 4

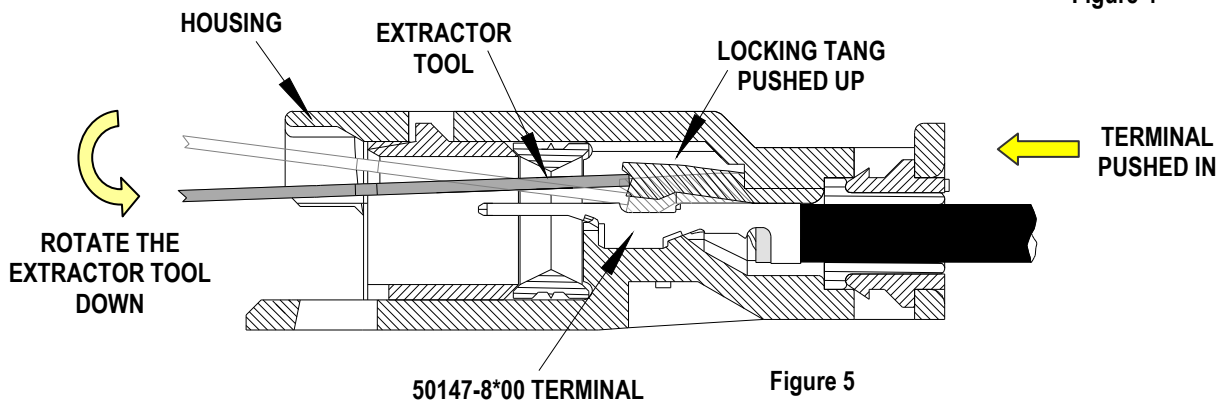

Figure 5

4. For terminal series 50148, push the terminal forward in the arrow direction before using the Extractor Tool.

5. Insert the tip of the Extractor Tool on an angle above the terminal into the slot on the bottom of the connector housing.
6. While rotating the extraction tool up, bend the terminal locking tang down and push the terminal back through the connector slot. Make sure that the terminated wire is pulled out at the same time. See Figure 6.

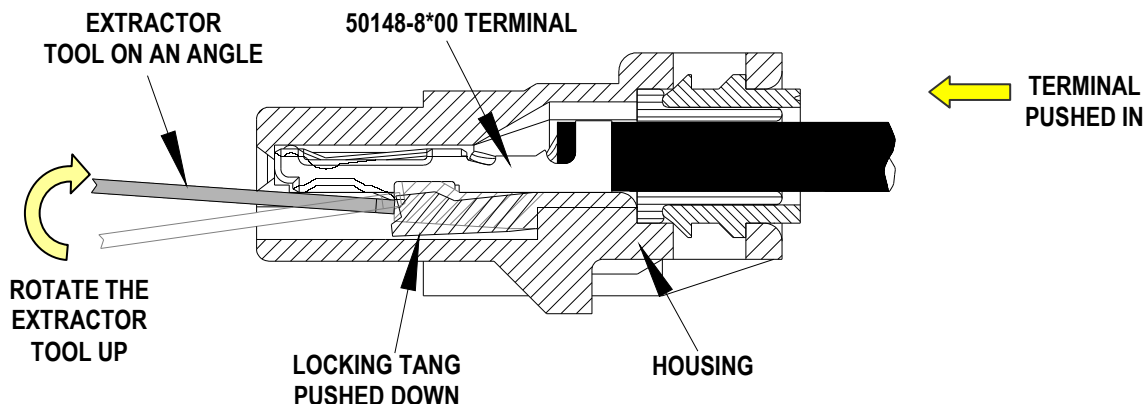

FIGURE 6

**For 50420 Terminal Series:**

1. Push the terminal forward in the arrow direction before using the Extractor Tool.
2. Insert the tip of the Extractor Tool on an angle above the terminal into the slot on the top of the connector housing.
3. While rotating the extraction tool down, bend the terminal locking tang down and push the terminal back through the connector slot. Make sure that the terminated wire is pulled out at the same time. See Figure 7.

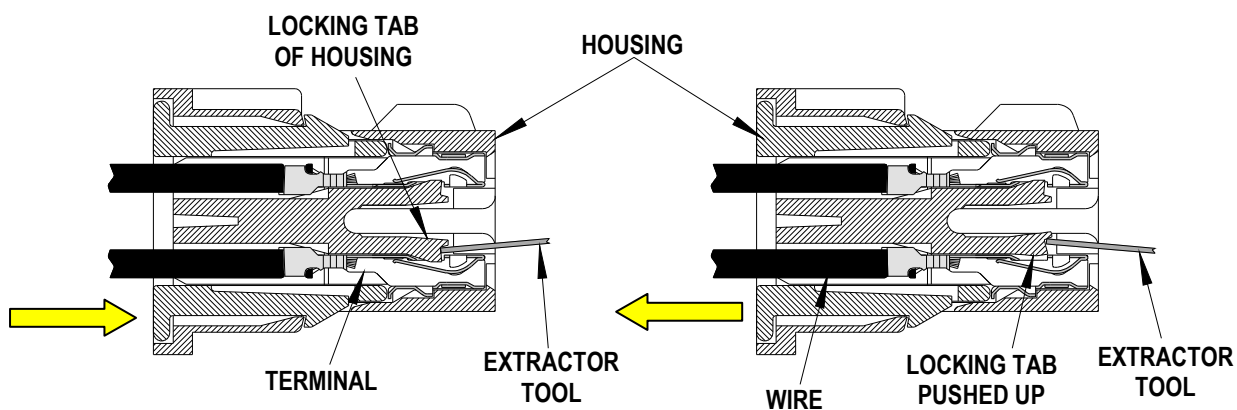

Figure 7

**For 502438 Terminal Series:**

1. Push the terminal forward in the arrow direction before using the Extractor Tool.
2. Insert the Extractor Tool into the slot above the terminal in the connector housing as shown in Figure 8.
3. Gently push the extractor tool till it stops. The housing locking tab should be bent up.
4. Pull the terminal and the terminated wire back through the Connector slot along with the extractor tool in the arrow direction as shown.

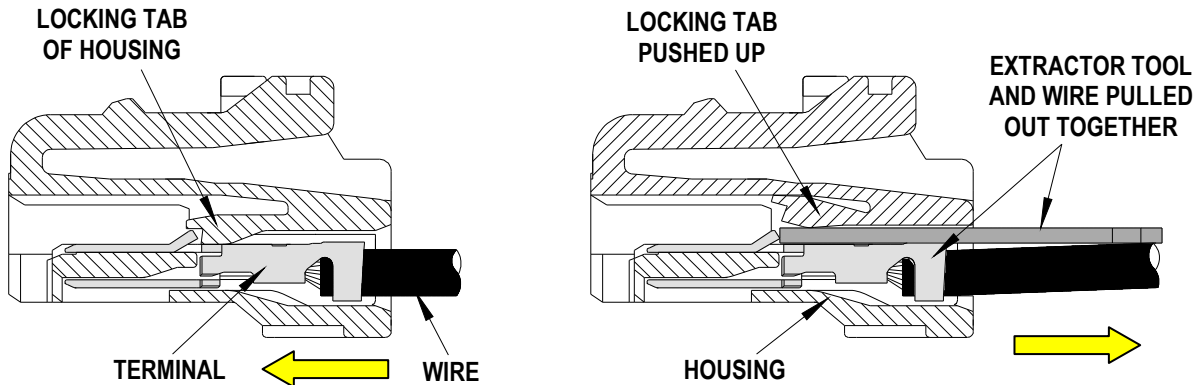

Figure 8

Molex does not offer repair parts for this Tools due to the inexpensive nature of the tool

**CAUTION:** Molex specifications are valid only when used with Molex terminals, applicators and tooling.

**Americas Headquarters**  
 Lisle, Illinois 60532 U.S.A.  
 1-800-78MOLEX  
 amerinfo@molex.com

**Far East North Headquarters**  
 Yamato, Kanagawa, Japan  
 81-462-65-2324  
 feninfo@molex.com

**Far East South Headquarters**  
 Jurong, Singapore  
 65-6-268-6868  
 fesinfo@molex.com

**European Headquarters**  
 Munich, Germany  
 49-89-413092-0  
 eurinfo@molex.com

**Corporate Headquarters**  
 2222 Wellington Ct.  
 Lisle, IL 60532 U.S.A.  
 630-969-4550  
 Fax: 630-969-1352

Visit our Web site at <http://www.molex.com>