



**HESTORE.HU**

elektronikai alkatrész áruház

**EN:** This Datasheet is presented by the manufacturer.

Please visit our website for pricing and availability at [www.hestore.hu](http://www.hestore.hu).

PRODUCT NUMBER  
95278-YXX-XXLF

- RoHS COMPATIBLE, NOTE 6.
- TOTAL NB OF POSITIONS 04 TO 50
- PACKAGING OPTIONS, NOTE 3.
- PIN STYLE SEE SHEET 2
- PLATING SEE SHEET 2

NOTES:

1. HOUSING MAT'L : HIGH TEMPERATURE THERMOPLASTIC. UL94V-0 COLOR: BLACK
2. PIN MATERIAL : PHOSPHOR BRONZE
- 3 - PACKAGING OPTIONS:  
 - = POLY BAGS  
 B = TUBE + CAP  
 A = TAPE & REEL WITH CAP, AS AVAILABLE  
 TR = CUSTOM TAPE & REEL WITH CAP, SEE TA840 ONLY FOR P/N 95278-102TR04LF AND P/N 95278-101TR10LF  
 T = TUBE WITHOUT PICK UP CAP  
 K = TAPE & REEL WITHOUT PICK UP CAP, AS AVAILABLE

4. 9N MIN RETENTION IN EITHER DIRECTION
5. TO DETERMINE DIMENSIONS :  
N = NUMBER OF POSITIONS PER ROW
6. RoHS COMPATIBLE PRODUCT SPECIFICATIONS

- a - PLATING:  
 - "LF" MEANS THE PRODUCT IS LEAD-FREE, 2µm MINIMUM MATTE TIN OVER 1.27µm MINIMUM NICKEL UNDERPLATE.
- b - MANUFACTURING PROCESS COMPATIBILITY  
 - THE HOUSING WILL WITHSTAND EXPOSURE TO 260°C PEAK TEMPERATURE FOR 30 SECONDES IN A CONVECTION, INFRA-RED OR VAPOR PHASE REFLOW OVEN.
- c - LABELING:  
 - MEETS PACKAGING SPECS AS PER GS-14-920
- d - LEGAL STATEMENT: SEE GS-47-0004

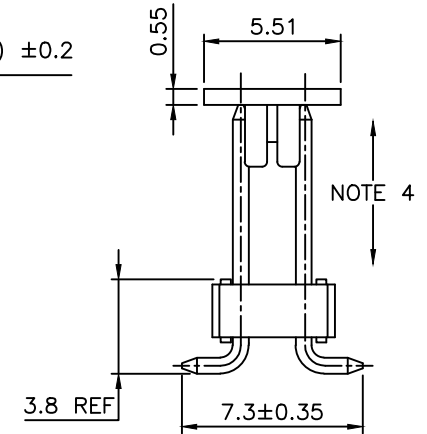
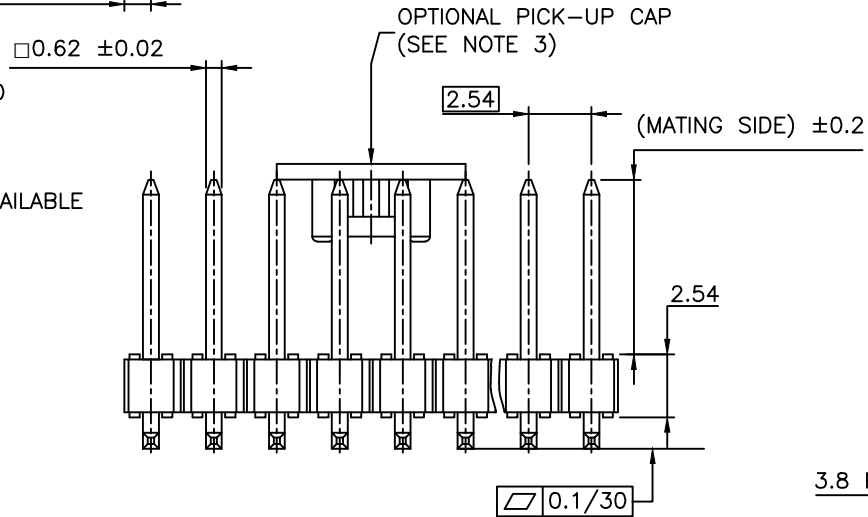
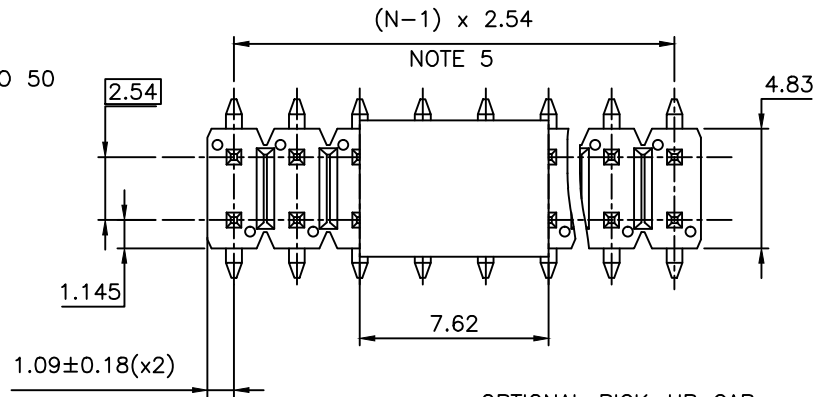

mat'l. code		surface		tolerance		projection		product family	
		ISO 1302		ISO 406 ISO 1101		mm		BERGSTIK	
ltr		ecn no		date		tolerances unless otherwise specified		title	
W		F-22120		BVE 15.10.09		x.x ± 0.3		UNSHR.HEADER DR SMT	
X		F-22217		BVE 15.10.19		x.xx ± 0.13			
Y		F-23055		AMA 16.01.15		x.xxx ± 0.05			
AA		F-23246		AMA 16.02.12		dr		scale 5:1	
AB		F-23258		AMA 16.02.15		enrg		D.LE 01.01.24	
AC		F-23474		JJU 16.03.08		chr		JM.C 01.01.24	
V		B-20561		AMA 15.03.26		appd		JF.N 01.01.24	
sheet		revision		AC		U		dwg no	
index		sheet		1		2		sheet 1 of 2	
								95278	
								A3	
								type	
								CUSTOMER Drawing	

PIN STYLE	MATING
01	5.9
02	8
03	9.9
04	11.4
05	9.2
06	10.4
07	5.3
09	17.00
10	8.10
11	8.50
12	3.05
13	14.35
14	4.00
15	6.60

PLATING

- 1 = 0.76µm GOLD/GXT ON CONTACT AREA, 2µm TIN MIN ON TAIL
- 4 = 2µm TIN MIN FULL PLATED
- 5 = 0.25µm GOLD/GXT ON CONTACT AREA, 2µm TIN MIN ON TAIL
- 8 = 0.38µm GOLD/GXT ON CONTACT AREA, 2µm TIN MIN ON TAIL
- 1.27µm NICKEL MIN UNDERLAYER FOR ALL PLATING VERSIONS

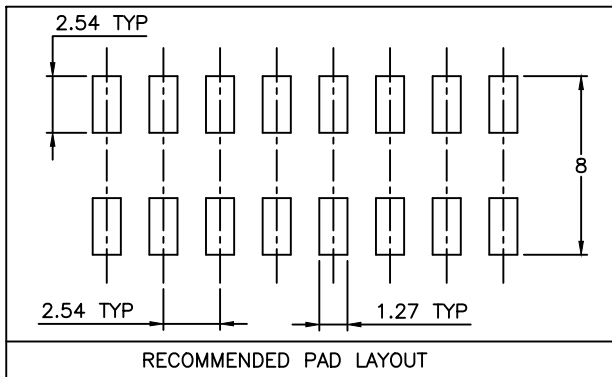

mat'l. code		surface		tolerance		projection		product family	
		ISO 1302 ✓		ISO 406 ISO 1101				BERGSTIK	
ltr	ecn no	dr	date	tolerances unless otherwise specified		mm		title	
N	F08-0253	LMU	08.12.10	angles		linear		UNSHR.HEADER	
P	B-18789	LMU	14.09.11					DR SMT	
R	B-18983	LMU	14.10.03			scale N/A		dwg no	
S	B-20276	LMU	15.02.16	dr	D.LE	01.01.24	sheet 2 of - size		
T	B-20561	AMA	15.03.26	enr	JM.C	01.01.24	95278 A3		
U	F-22120	BVE	15.10.09	chr	JM.C	01.01.24	type CUSTOMER Drawing		
				appd	JF.N	01.01.24			
sheet index	revision sheet								