



HESTORE.HU

elektronikai alkatrész áruház

EN: This Datasheet is presented by the manufacturer.

Please visit our website for pricing and availability at www.hestore.hu.



2.7 V to 5.5 V Serial Infrared Transceiver Module Family (SIR, 115.2 kbit/s)



Description

The TFDU4100, TFDS4500, and TFDT4500 are a family of low-power infrared transceiver modules compliant to the IrDA 1.2 standard for serial infrared (SIR) data communication, supporting IrDA speeds up to 115.2 kbit/s. Integrated within the transceiver modules are a photo PIN diode, infrared emitter (IRED), and a low-power analog control IC to provide a total front-end solution in a single package. Telefunken's SIR transceivers are available in three package options, including our BabyFace package (TFDU4100), the smallest SIR transceiver available

on the market. This wide selection provides flexibility for a variety of applications and space constraints. The transceivers are capable of directly interfacing with a wide variety of I/O chips which perform the pulse-width modulation/demodulation function, including Telefunken's TOIM3000/TOIM3232. At a minimum, a current-limiting resistor in series with the infrared emitter and a V_{CC} bypass capacitor are the only external components required to implement a complete solution.

Features

- Compliant to IrDA 1.2 (Up to 115.2 kbit/s)
- 2.7 to 5.5 V Wide Operating Voltage Range
- Low-Power Consumption (1.3 mA Supply Current)
- Power Sleep Mode Through V_{CC1} /SD Pin (5 nA Sleep Current)
- Long Range (Up to 3.0 m at 115.2 kbit/s)
- Three Surface Mount Package Options
 - Universal ($9.7 \times 4.7 \times 4.0$ mm)
 - Side View ($13.0 \times 5.95 \times 5.3$ mm)
 - Top View ($13.0 \times 7.6 \times 5.95$ mm)
- BabyFace (Universal) Package Capable of Surface Mount Solderability to Side and Top View Orientation
- Directly Interfaces with Various Super I/O and Controller Devices and Telefunken's TOIM3000 and TOIM3232 I/Os
- Built-In EMI Protection – No External Shielding Necessary
- Few External Components Required
- Backward Compatible to all Telefunken SIR Infrared Transceivers

Applications

- Notebook Computers, Desktop PCs, Palmtop Computers (Win CE, Palm PC), PDAs
- Digital Still and Video Cameras
- Printers, Fax Machines, Photocopiers, Screen Projectors
- Telecommunication Products (Cellular Phones, Pagers)
- Internet TV Boxes, Video Conferencing Systems
- External Infrared Adapters (Dongles)
- Medical and Industrial Data Collection Devices

Package Options

TFDU4100
Baby Face (Universal)



TFDS4500
Side View



TFDT4500
Top View



Ordering Information

| Part Number | Qty / Reel | Description |
|--------------|------------|---|
| TFDU4100-TR3 | 1000 pcs | Oriented in carrier tape for side view surface mounting |
| TFDU4100-TT3 | 1000 pcs | Oriented in carrier tape for top view surface mounting |
| TFDS4500-TR3 | 750 pcs | |
| TFDT4500-TR3 | 750 pcs | |

Functional Block Diagram

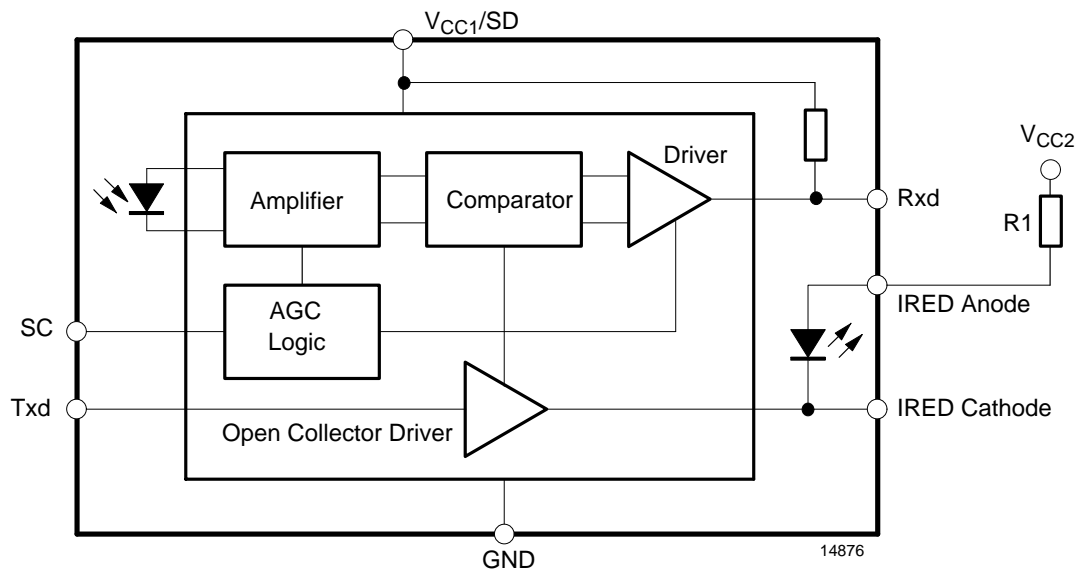
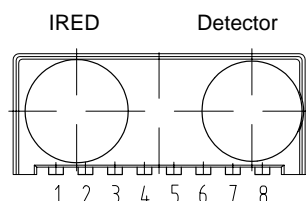

Figure 1. Functional Block Diagram

Pin Description

| Pin Number | | Function | Description | I/O | Active |
|--------------------|------------|----------------|---|-----|--------|
| "U" and "T" Option | "S" Option | | | | |
| 1 | 8 | IRED Anode | IRED anode, should be externally connected to V_{CC2} through a current control resistor | | |
| 2 | 1 | IRED Cathode | IRED cathode, internally connected to driver transistor | | |
| 3 | 7 | Txd | Transmit Data Input | I | HIGH |
| 4 | 2 | Rxd | Received Data Output, open collector. No external pull-up or pull-down resistor is required (20 k Ω resistor internal to device). Pin is inactive during transmission. | O | LOW |
| 5 | 6 | NC | Do not connect | | |
| 6 | 3 | V_{CC1} / SD | Supply Voltage / Shutdown | | |
| 7 | 5 | SC | Sensitivity control | I | HIGH |
| 8 | 4 | GND | Ground | | |

“U” Option BabyFace (Universal)



14885

“S” Option Side View

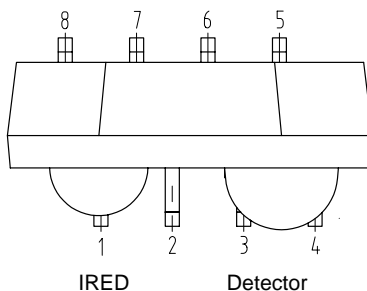

“T” Option Top View

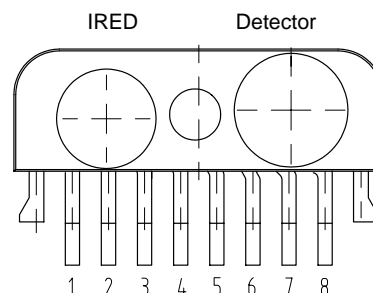

Figure 2. Pinnings

Absolute Maximum Ratings

Reference point Pin GND unless otherwise noted.

Typical values are for DESIGN AID ONLY, not guaranteed nor subject to production testing.

| Parameters | Test Conditions | Symbol | Min. | Typ. | Max. | Unit |
|--|-------------------------------------|-----------------|-------|------|---------------|-------|
| Supply Voltage Range | | V_{CC1} | - 0.5 | | 6 | V |
| Input Currents | For all Pins, except IRED Anode Pin | | | | 10 | mA |
| Output Sink Current | | | | | 25 | mA |
| Power Dissipation | See Derating Curve | P_D | | | 200 | mW |
| Junction Temperature | | T_J | | | 125 | °C |
| Ambient Temperature Range (Operating) | | T_{amb} | -25 | | +85 | °C |
| Storage Temperature Range | | T_{stg} | -25 | | +85 | °C |
| Soldering Temperature | See Recommended Solder Profile | | | 215 | 240 | °C |
| Average IRED Current | | $I_{IRED (DC)}$ | | | 100 | mA |
| Repetitive Pulsed IRED Current | $t < 90 \mu s, t_{on} < 20\%$ | $I_{IRED (RP)}$ | | | 500 | mA |
| IRED Anode Voltage | | $V_{IRED A}$ | - 0.5 | | $V_{CC1}+0.5$ | V |
| Transmitter Data Input Voltage | | V_{Txd} | - 0.5 | | $V_{CC1}+0.5$ | V |
| Receiver Data Output Voltage | | V_{Rxd} | - 0.5 | | $V_{CC1}+0.5$ | V |
| Virtual Source Size | Method: (1-1/e) encircled energy | d | 2.5 | 2.8 | | mm |
| Maximum Intensity for Class 1 Operation of IEC825-1 or EN60825-1 (worst case IrDA SIR pulse pattern *) | EN60825, 1997 | | | | 400 | mW/sr |

* Note:

Transmitted data: continuously transmitted “0”. In normal data transfer operation “0” and “1” will be transmitted with the same probability. Therefore, for that case, about a factor of two of safety margin is included. However, for worst case thermal stress testing such data pattern are often used and for this case the 400 mW/sr value has to be taken.



Electrical Characteristics

$T_{amb} = 25^{\circ}\text{C}$, $V_{CC} = 2.7\text{ V}$ to 5.5 V unless otherwise noted.

Typical values are for DESIGN AID ONLY, not guaranteed nor subject to production testing.

| Parameters | Test Conditions / Pins | Symbol | Min. | Typ. | Max. | Unit |
|---|--|----------------|------------|------------|------------|---------------|
| Transceiver | | | | | | |
| Supply Voltage | Receive Mode Transmit Mode, $R_2 = 47\ \Omega$ (see Recommended Application Circuit) | V_{CC1} | 2.7 2.0 | | 5.5 5.5 | V V |
| Supply Current Pin V_{CC1} (Receive Mode) | $V_{CC1} = 5.5\text{ V}$ $V_{CC1} = 2.7\text{ V}$ | I_{CC1} (Rx) | | 1.3 1.0 | 2.5 1.5 | mA mA |
| Supply Current Pin V_{CC1} (avg) (Transmit Mode) | $I_{IRED} = 210\text{ mA}$ (at IRED Anode Pin) $V_{CC1} = 5.5\text{ V}$ $V_{CC1} = 2.7\text{ V}$ | I_{CC1} (Tx) | | 5.0 3.5 | 5.5 4.5 | mA mA |
| Leakage Current of IR Emitter, IRED Anode Pin | $V_{CC1} = \text{OFF}$, $T_{XD} = \text{LOW}$, $V_{CC2} = 6\text{ V}$, $T = 25\text{ to }85^{\circ}\text{C}$ | I_L (IREDA) | | 0.005 | 0.5 | μA |
| Transceiver Power On Settling Time | | T_{PON} | | 50 | | μs |

Optoelectronic Characteristics

$T_{amb} = 25^{\circ}\text{C}$, $V_{CC} = 2.7\text{ V}$ to 5.5 V unless otherwise noted.

Typical values are for DESIGN AID ONLY, not guaranteed nor subject to production testing.

| Parameters | Test Conditions | Symbol | Min. | Typ. | Max. | Unit |
|---|--|-------------|-----------------|------|------|------------------------|
| Receiver | | | | | | |
| Minimum Detection Threshold Irradiance | BER = 10^{-8} (IrDA Specification) | | | | | |
| | $\alpha = \pm 15^{\circ}$, SIR Mode, SC = LOW | E_e | | 20 | 35 | mW/m^2 |
| | $\alpha = \pm 15^{\circ}$, SIR Mode, SC = HIGH | E_e | 6 | 10 | 15 | mW/m^2 |
| Maximum Detection Threshold Irradiance | $\alpha = \pm 90^{\circ}$, SIR Mode, $V_{CC1} = 5\text{ V}$ | E_e | 3.3 | 5 | | kW/m^2 |
| | $\alpha = \pm 90^{\circ}$, SIR Mode, $V_{CC1} = 3\text{ V}$ | E_e | 8 | 15 | | kW/m^2 |
| Logic LOW Receiver Input Irradiance | SC = HIGH or LOW | E_e | | | 4 | mW/m^2 |
| Output Voltage – Rxd | Active, C = 15 pF, R = 2.2 k Ω | V_{OL} | | 0.5 | 0.8 | V |
| | Non-active, C = 15 pF, R = 2.2 k Ω | V_{OH} | $V_{CC1} - 0.5$ | | | V |
| Output Current – Rxd | $V_{OL} < 0.8\text{ V}$ | I_{OL} | | 4 | | mA |
| Rise Time – Rxd | C = 15 pF, R = 2.2 k Ω | t_r (Rxd) | 20 | | 1400 | ns |
| Fall Time – Rxd | C = 15 pF, R = 2.2 k Ω | t_f (Rxd) | 20 | | 200 | ns |
| Pulse Width – Rxd Output | Input pulse width = 1.6 μs , 115.2 kbit/s | t_{PW} | 1.41 | | 8 | μs |
| Jitter, Leading Edge of Output Signal | Over a Period of 10 bit, 115.2 kbit/s | t_j | | | 2 | μs |
| Latency | | t_L | | 100 | 500 | μs |

**Optoelectronic Characteristics**

$T_{amb} = 25^{\circ}\text{C}$, $V_{CC} = 2.7\text{ V}$ to 5.5 V unless otherwise noted.

Typical values are for DESIGN AID ONLY, not guaranteed nor subject to production testing.

| Parameters | Test Conditions | Symbol | Min. | Typ. | Max. | Unit |
|---|--|----------------------------|------|----------|---------------|---------------|
| Transmitter | | | | | | |
| IRED Operating Current | IRED Operating Current can be adjusted by Variation of R1. Current Limiting Resistor is in Series to IRED: $R1 = 14\ \Omega$, $V_{CC2} = 5.0\text{ V}$ | I_{IRED} | | 0.2 | 0.28 | A |
| Logic LOW Transmitter Input Voltage | | $V_{IL}(\text{Txd})$ | 0 | | 0.8 | V |
| Logic HIGH Transmitter Input Voltage | | $V_{IH}(\text{Txd})$ | 2.4 | | $V_{CC1}+0.5$ | V |
| Output Radiant Intensity | In Agreement with IEC825 Eye Safety Limit, if Current Limiting Resistor is in Series to IRED: $R1 = 14\ \Omega$, $V_{CC2} = 5.0\text{ V}$, $\alpha = \pm 15^{\circ}$ | I_e | 45 | 140 | 200 | mW/sr |
| | Txd Logic LOW Level | I_e | | | 0.04 | mW/sr |
| Angle of Half Intensity | | α | | ± 24 | | $^{\circ}$ |
| Peak Wavelength of Emission | | λ_p | 880 | | 900 | nm |
| Half-Width of Emission Spectrum | | | | 60 | | nm |
| Optical Rise Time, Fall Time | | t_{ropt} , t_{fopt} | | 200 | 600 | ns |
| Optical Overshoot | | | | | 25 | % |
| Rising Edge Peak-to-Peak Jitter of Optical Output Pulse | Over a Period of 10 bits, Independent of Information content | | | | 0.2 | μs |



Recommended Circuit Diagram

The only required components for designing an IrDA 1.2 compatible design using Telefunken SIR transceivers are a current limiting resistor to the IRED. However, depending on the entire system design and board layout, additional components may be required (see figure 3).

It is recommended that the capacitors C1 and C2 are positioned as near as possible to the transceiver power supply pins. A tantalum capacitor should be used for C1, while a ceramic capacitor should be used for C2 to suppress RF noise. Also, when connecting the described circuit to the power supply, low impedance wiring should be used.

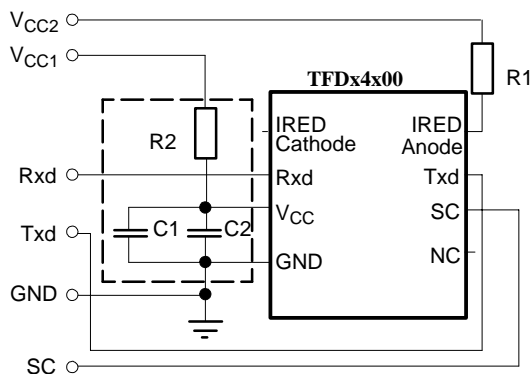

Note: Outlined components are optional depending on the quality of the power supply.

14877

Figure 3. Recommended Application Circuit

R1 is used for controlling the current through the IR emitter. For increasing the output power of the IRED, the value of the resistor should be reduced. Similarly, to reduce the output power of the IRED, the value of the resistor should be increased. For typical values of R1 (see figures 4 and 5), e.g. for IrDA compliant operation ($V_{CC2} = 5\text{ V} \pm 5\%$), a current control resistor of $14\ \Omega$ is recommended. The upper drive current limitation is dependent on the duty cycle and is given by the absolute maximum ratings on the data sheet and the eye safety limitations given by IEC825-1.

R2, C1 and C2 are optional and dependent on the quality of the supply voltage V_{CC1} and injected noise. An unstable power supply with dropping voltage during transmission may reduce sensitivity (and transmission range) of the transceiver.

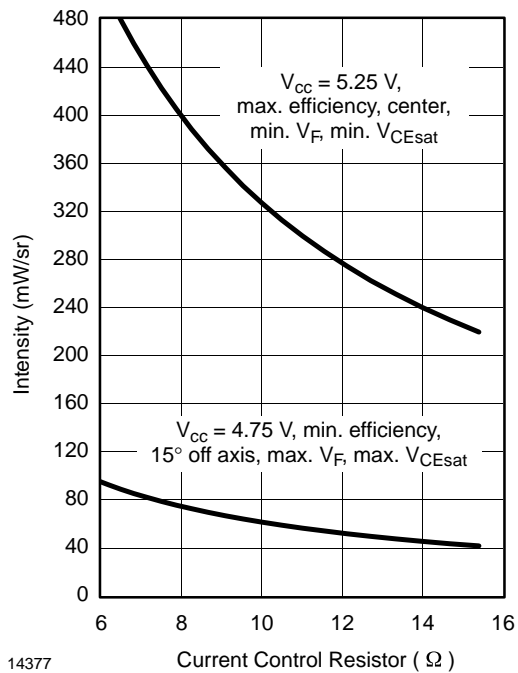

14377

Figure 4. I_e vs. R_I

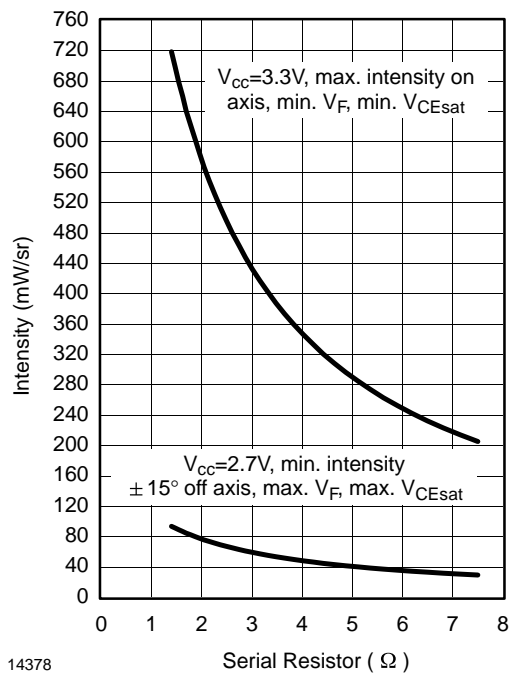

14378

Figure 5. I_e vs. R_I

Table 1. Recommended Application Circuit Components

| Component | Recommended Value |
|-----------|---|
| C1 | 4.7 μF , Tantalum |
| C2 | 0.1 μF , Ceramic |
| R1 | 14 Ω , 0.25 W (recommend using two 7 Ω , 0.125 W resistors in series) |
| R2 | 47 Ω , 0.125 W |

The sensitivity control (SC) pin allows the minimum detection irradiance threshold of the transceiver to be lowered when set to a logic HIGH. Lowering the irradiance threshold increases the sensitivity to infrared signals and increases transmission range up to 3 meters. However, setting the Pin SC to logic HIGH also makes the transceiver more susceptible to transmission errors due to an increased sensitivity to fluorescent light disturbances. It is recommended to set the Pin SC to logic LOW or left open if the increased range is not required or if the system will be operating in bright ambient light.

The guide pins on the side-view and top-view packages are internally connected to ground but should not be connected to the system ground to avoid ground loops. They should be used for mechanical purposes only and should be left floating.

Shutdown

The internal switch for the IRED in Telefunken SIR transceivers is designed to be operated like an open collector driver. Thus, the V_{CC2} source can be an unregulated power supply while only a well regulated power source with a supply current of 1.3 mA connected to V_{CC1}/SD is needed to provide power to the remainder of the transceiver circuitry in receive mode. In transmit mode, this current is slightly higher (approximately 4 mA average at 3 V supply current) and the voltage is not required to be kept as stable as in receive mode. A voltage drop of V_{CC1} is acceptable down to about 2.0 V when buffering the voltage directly from the Pin V_{CC1} to GND see figure 3).

This configuration minimizes the influence of high current surges from the IRED on the internal analog control circuitry of the transceiver and the application circuit. Also board space and cost savings can be achieved by eliminating the additional linear regulator normally needed for the IRED's high current requirements.

The transceiver can be very efficiently shutdown by keeping the IRED connected to the power supply V_{CC2} but switching off V_{CC1}/SD . The power source to V_{CC1}/SD can be provided directly from a microcontroller (see figure 6). In shutdown, current loss is realized only as leakage current through the current limiting resistor to the IRED (typically 5 nA). The settling time after switching V_{CC1}/SD on again is

approximately 50 μ s. Telefunken's TOIM3232 interface circuit is designed for this shutdown feature. The V_{CC_SD} , S0 or S1 outputs on the TOIM3232 can be used to power the transceiver with the necessary supply current.

If the microcontroller or the microprocessor is unable to drive the supply current required by the transceiver, a low-cost SOT23 npn transistor can be used to switch voltage on and off from the regulated power supply (see figure 7). The additional component cost is minimal and saves the system designer additional power supply costs.

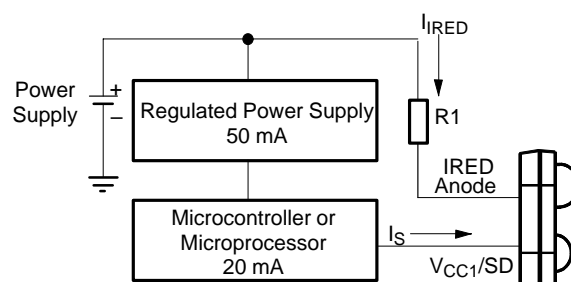

TFDU4100 (Note: Typical Values Listed)
Receive Mode

@ 5 V: $I_{IRED} = 210$ mA, $I_S = 1.3$ mA

@ 2.7 V: $I_{IRED} = 210$ mA, $I_S = 1.0$ mA

Transmit Mode

@ 5 V: $I_{IRED} = 210$ mA, $I_S = 5$ mA (Avg.)

@ 2.7 V: $I_{IRED} = 210$ mA, $I_S = 3.5$ mA (Avg.) 14878

Figure 6.

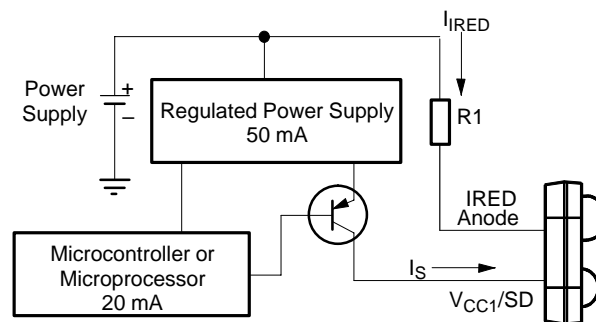

TFDU4100 (Note: Typical Values Listed)
Receive Mode

@ 5 V: $I_{IRED} = 210$ mA, $I_S = 1.3$ mA

@ 2.7 V: $I_{IRED} = 210$ mA, $I_S = 1.0$ mA

Transmit Mode

@ 5 V: $I_{IRED} = 210$ mA, $I_S = 5$ mA (Avg.)

@ 2.7 V: $I_{IRED} = 210$ mA, $I_S = 3.5$ mA (Avg.) 14879

Figure 7.

Recommended SMD Pad Layout

The leads of the device should be soldered in the center position of the pads.

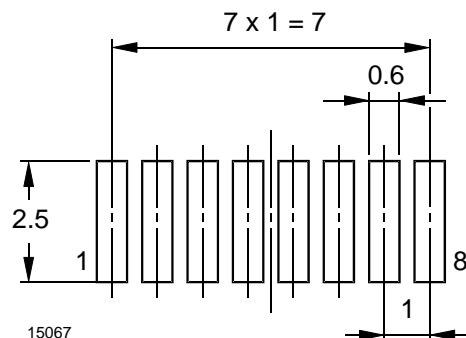

Figure 8. TFDU4100 BabyFace (Universal)

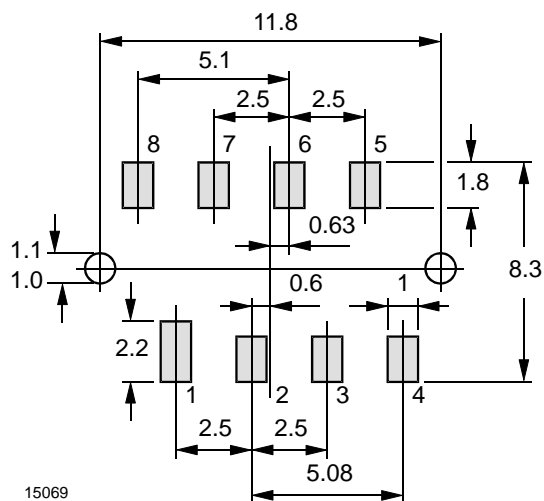

Figure 9. TFDS4500 Side View Package

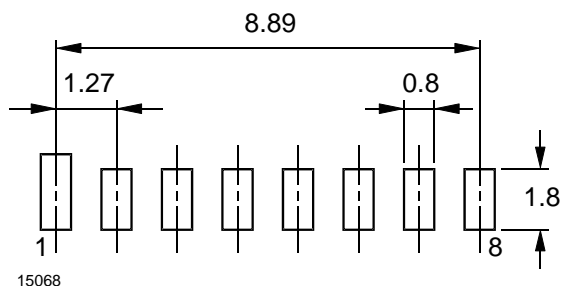

Figure 10. TFDT4500 Top View Package

Note: Leads of the device should be at least 0.3 mm within the ends of the pads.
Pad 1 is longer to designate Pin 1 connection to transceiver.



Recommended Solder Profile

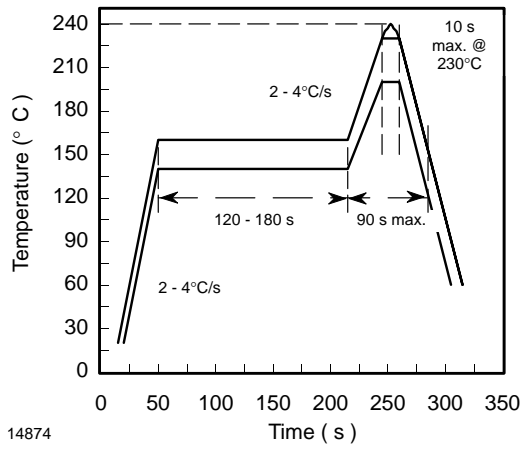

Figure 11. Recommended Solder Profile

Current Derating Diagram

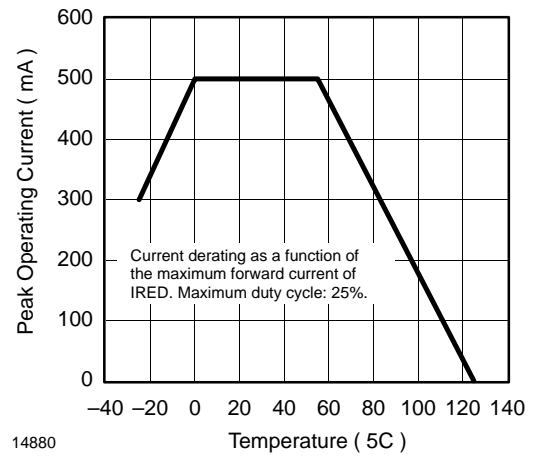
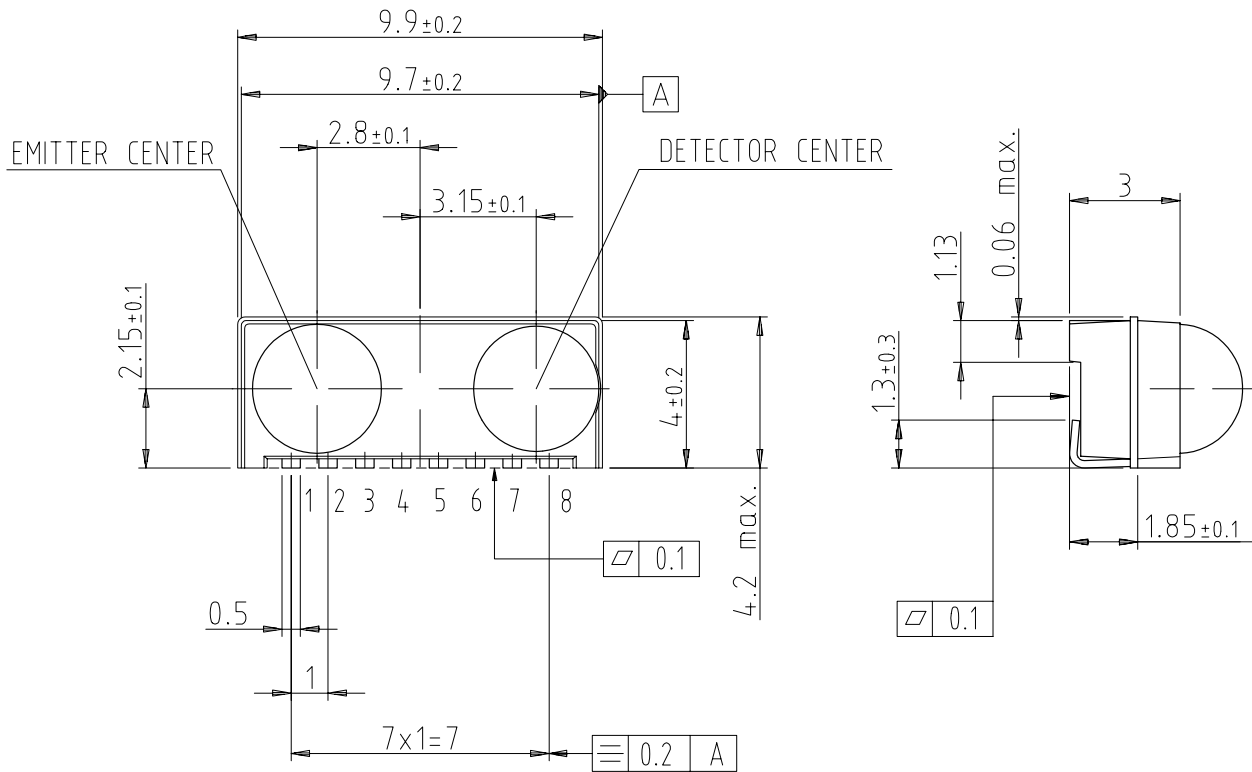

Figure 12. Current Derating Diagram



TFDU4100 – BabyFace (Universal) Package (Mechanical Dimensions)



* MARKING SAMPLE ONLY

PICK + PLACE AREA

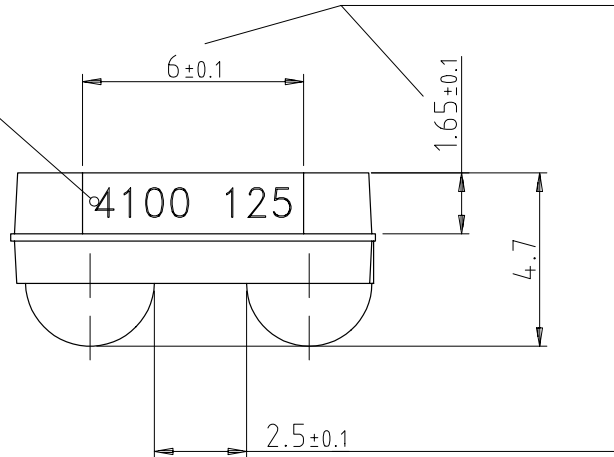

* MARKING ORIENTATION
180 DEGREES ALLOWED

Drawing-No.: 6.550-5148.01-4
Issue: 7; 19.05.98

12249

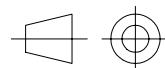

technical drawings
according to DIN
specifications

TFDS4500 – Side View Package (Mechanical Dimensions)

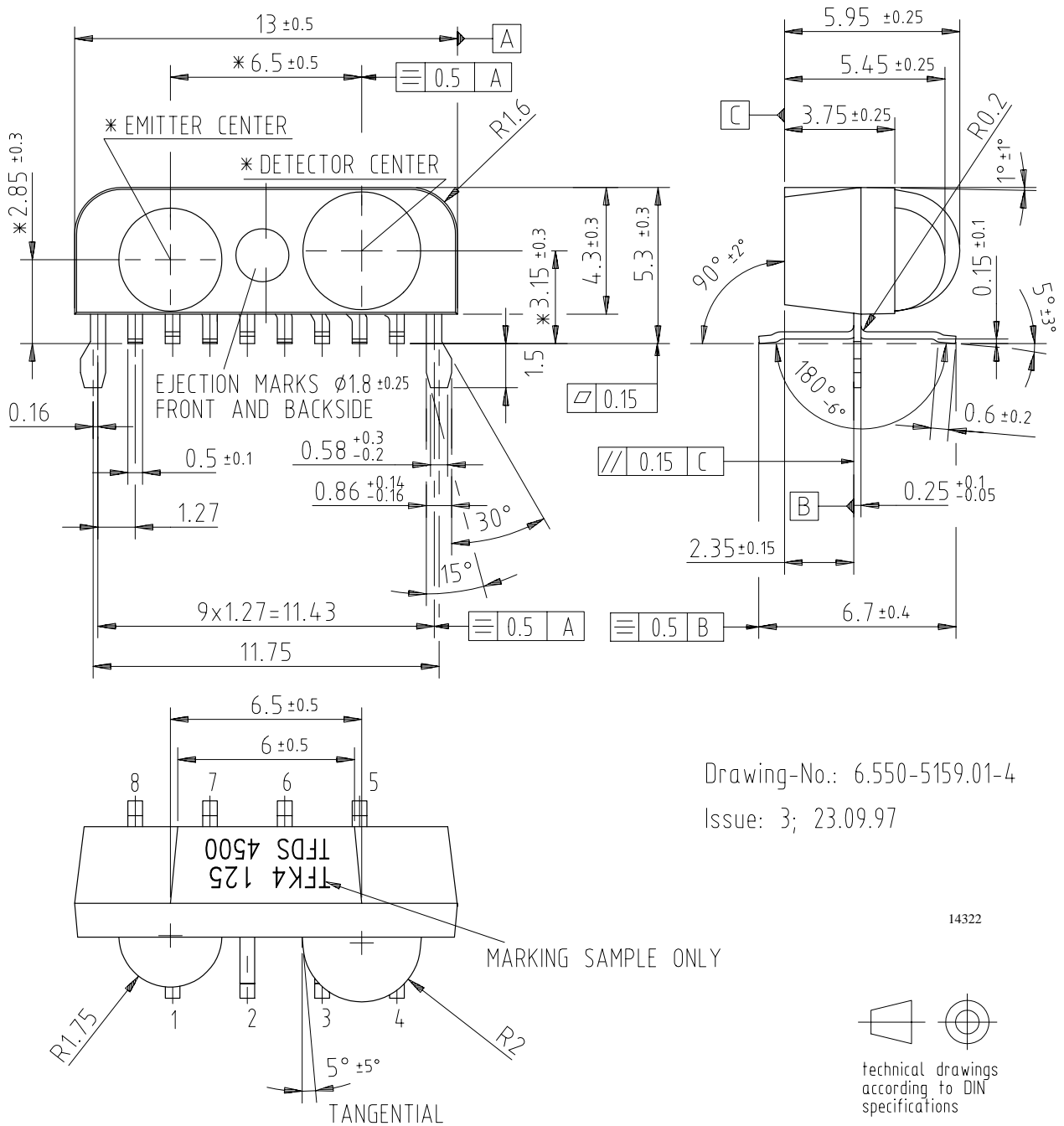

Drawing-No.: 6.550-5159.01-4

Issue: 3; 23.09.97

14322

technical drawings
according to DIN
specifications

TFDT4500 – Top View Package (Mechanical Dimensions)

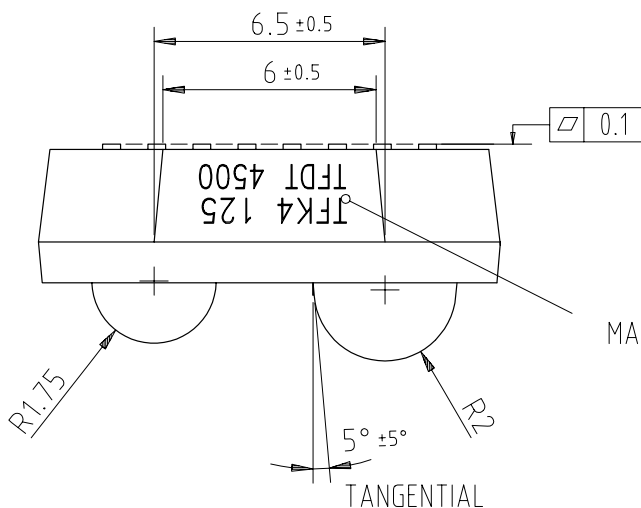
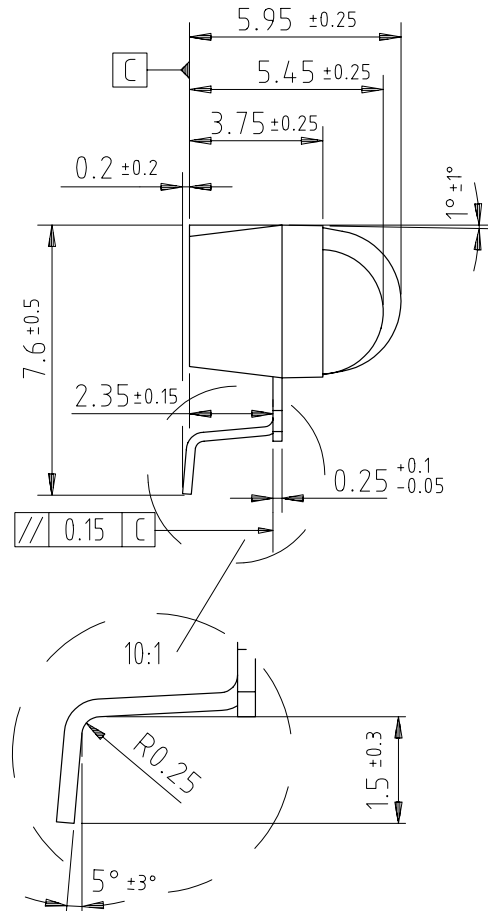
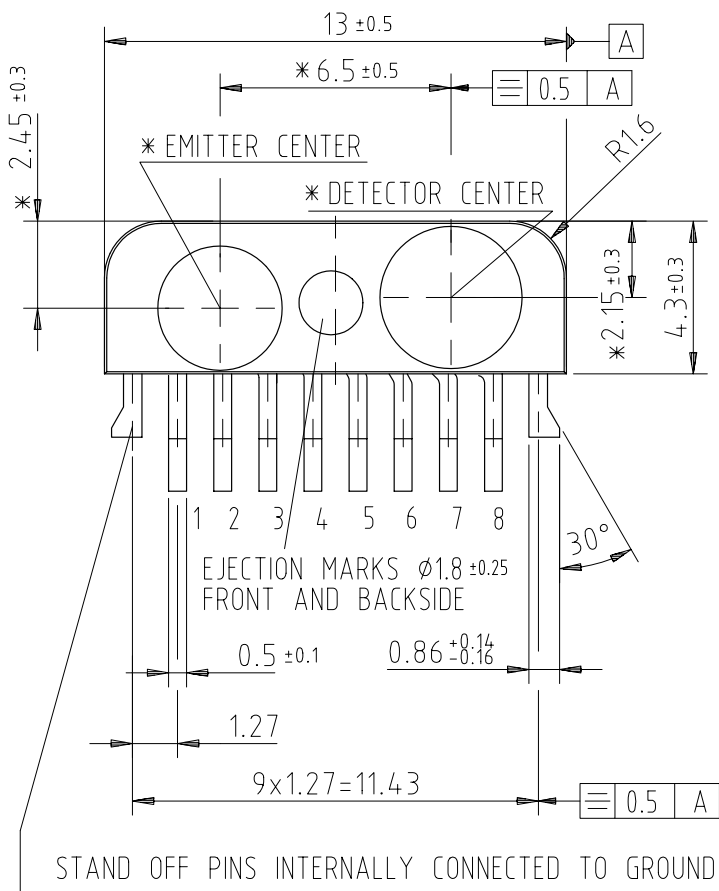

Drawing-No.: 6.550-5160.01-4
Issue: 3; 23.09.97

14325

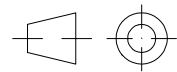

technical drawings
according to DIN
specifications



Ozone Depleting Substances Policy Statement

It is the policy of **Vishay Semiconductor GmbH** to

1. Meet all present and future national and international statutory requirements.
2. Regularly and continuously improve the performance of our products, processes, distribution and operating systems with respect to their impact on the health and safety of our employees and the public, as well as their impact on the environment.

It is particular concern to control or eliminate releases of those substances into the atmosphere which are known as ozone depleting substances (ODSs).

The Montreal Protocol (1987) and its London Amendments (1990) intend to severely restrict the use of ODSs and forbid their use within the next ten years. Various national and international initiatives are pressing for an earlier ban on these substances.

Vishay Semiconductor GmbH has been able to use its policy of continuous improvements to eliminate the use of ODSs listed in the following documents.

1. Annex A, B and list of transitional substances of the Montreal Protocol and the London Amendments respectively
2. Class I and II ozone depleting substances in the Clean Air Act Amendments of 1990 by the Environmental Protection Agency (EPA) in the USA
3. Council Decision 88/540/EEC and 91/690/EEC Annex A, B and C (transitional substances) respectively.

Vishay Semiconductor GmbH can certify that our semiconductors are not manufactured with ozone depleting substances and do not contain such substances.

We reserve the right to make changes to improve technical design and may do so without further notice.

Parameters can vary in different applications. All operating parameters must be validated for each customer application by the customer. Should the buyer use Vishay Telefunken products for any unintended or unauthorized application, the buyer shall indemnify Vishay Telefunken against all claims, costs, damages, and expenses, arising out of, directly or indirectly, any claim of personal damage, injury or death associated with such unintended or unauthorized use.

Vishay Semiconductor GmbH, P.O.B. 3535, D-74025 Heilbronn, Germany
Telephone: 49 (0) 7131 67 2831, Fax number: 49 (0) 7131 67 2423