



HESTORE.HU

elektronikai alkatrész áruház

EN: This Datasheet is presented by the manufacturer.

Please visit our website for pricing and availability at www.hestore.hu.



Product information MAB 5 SH schwarz/black

Industrial Connecting Solutions: Circular Connectors: Audio/Video Connectors: DIN EN 60 130-09 Connectors (MAS/MAK series): without locking screw: Panel-mounted sockets: MAB 5 SH schwarz/black
<http://www.e-catalog.beldensolutions.com/link/57078-24228-256281-256282-24384-24385-24386-34514/en/conf/ui/state>

Name	MAB 5 SH schwarz/black
	
	panel-mounted socket for PCBs; not shielded; plug-in direction parallel to the PCB, recommended board thickness 1.5 mm; additionally fixing with screws (DIN 40081)
Delivery informations	
Availability	available
Product description	
Type	MAB 5 SH schwarz/black
Order No.	931 744-500
Type of contact	female
Description	panel-mounted socket for PCBs; not shielded; plug-in direction parallel to the PCB, recommended board thickness 1.5 mm; additionally fixing with screws (DIN 40081)
Colour	black
Number of contacts	5
Conductor size	$\leq 0.34 \text{ mm}^2$
Technical data	
LF output "Phone"	EN 60 130-09
Pole arrangement DIN	DIN 41 524
Rated current	4 A
Rated voltage	AC/DC 34 V
Type of termination	solder
Material	
Contact material (socket)	brass
Contact surface material	tin plated
Contact bearer material	PBT/UL standard 94 V-0
Housing material	PBT/UL standard 94 V-0
Environmental conditions	
Protection class (IEC 60529)	IP 30
Temperature range	-20 °C to +60 °C

Picture
Drawing

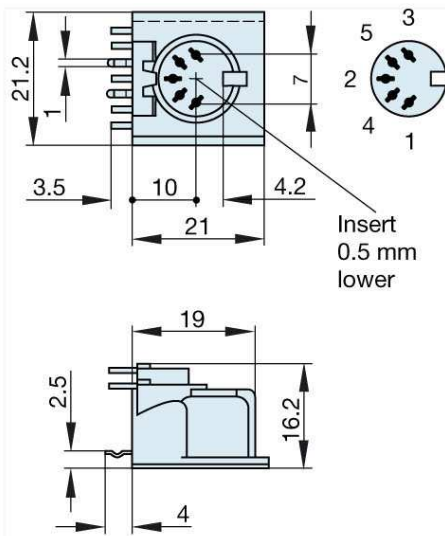

Arrangement of the soldering points on the components side

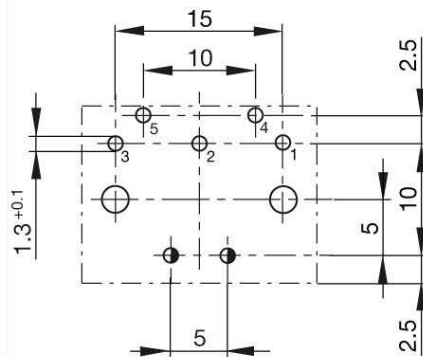

- : Two holes 2.4 in diameter for additional fixing with pan-head tapping screws, size ST 2.2 ... DIN ISO 1481.
- : Recommended hole diameter for locking spike 1.3 ± 0.05.



HIRSCHMANN

A **BELDEN** BRAND

Belden Deutschland GmbH

Im Gewerbepark 2

58579 Schalksmühle

Germany

Phone: +49 7127/14-1806

E-Mail: icos-sales@belden.com

The information published in the websites has been compiled as carefully as possible. It is subject to alteration without notice in technical as well as in price-related/commercial respect. The complete information and data were available on user documentation. Mandatory information can only be obtained by a concrete query.