



**HESTORE.HU**

elektronikai alkatrész áruház

**EN:** This Datasheet is presented by the manufacturer.

Please visit our website for pricing and availability at [www.hestore.hu](http://www.hestore.hu).



# Shenzhen Fine Offset Electronics Co., Ltd 深圳市欧赛特电子有限公司

Address: 4/F, Block C, Jiujiu Industrial City, Shajing Town, Bao'an District, Shenzhen City, China

This kit includes a wind vane ,cup anemometer, and tipping bucket rain gauge, with associated mounting hardware .These sensors contain no active electronics, instead using sealed magnetic reed switches and magnets to take measurements. A voltage must be supplied to each instrument to produce an output.

## Assembly

The wind sensor arm mounts on top of the two-piece metal and supports the wind vane and anemometer. A short cable connects the two win sensors. Plastic clips on the underside of the arm hold this cable in place. Screws are provided to secure the sensors to the arm. The rain gauge may be mounted lower on the mast using its own mounting arm and screw, or it may be mounted independently.

## Rain Gauge

雨量计为翻斗式的，每次发生一次翻斗为 0.3mm 的雨量。当雨斗翻转时会造成干簧管的一次闭合，可通过微处理器中断输入来记录翻斗次数,在 RJ11 水晶头的一端需连接一个电阻电容，如图所示：

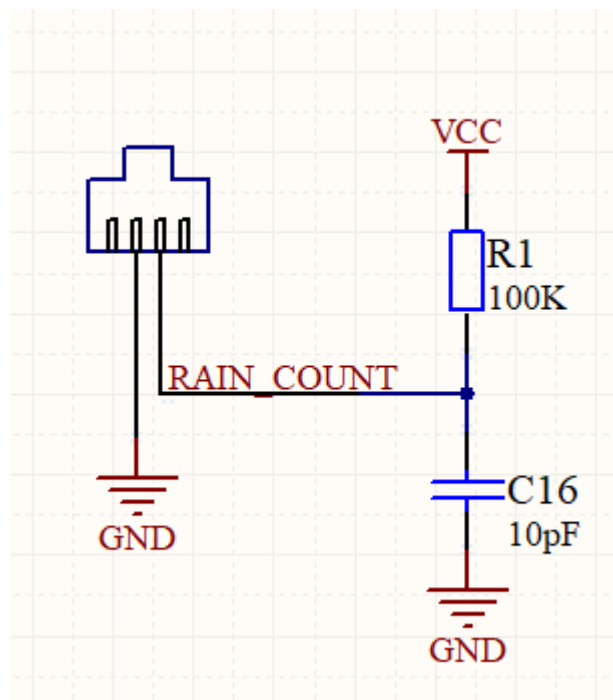

The rain gauge is a self-emptying tipping bucket type. Each 0.2794mm of rain cause one momentary contact closure that can be recorded with a digital counter or microcontroller interrupt input. The gauge's switch is connected to the two center conductors of the attached RJ 11-terminated cable.

## Anemometer

杯式风速计测量风速的方法是当磁铁通过开关时关闭触点。风速 0.33m/s 导致开关关闭一次。风速计将连接到风向计上，与风向计公用 RJ11 电缆，风速计占用 RJ11 水晶头的 2、3 脚。

The cup-type anemometer measures wind speed by closing a contact as a magnet moves past a switch. A wind speed of 2.4km/h causes the switch to close once per second.

The anemometer switch is connected to the inner two conductors of the RJ 11 cable shared by



the anemometer and wind vane(pins 2 and 3)

Wind Vane

风向计它有八个开关，每个开关连接到一个不同的电阻器。叶片的磁铁可以同时关闭两个开关，使多达 16 个不同的位置被指示。外部电阻可以用来形成一个分压器，产生一个电压输出，可以用 a/d 转换器来测量，如下所示。

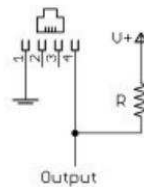
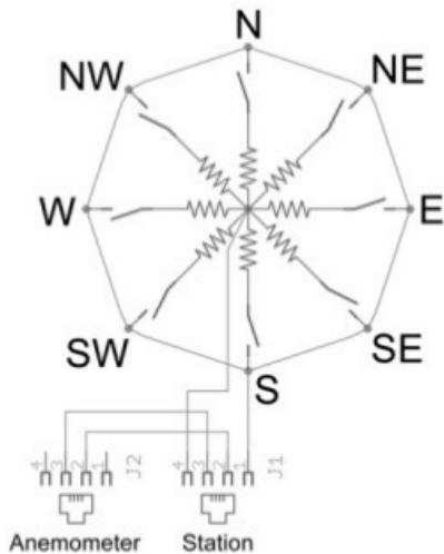

Example wind vane interface circuit. Voltage readings for a 5 volt supply and a resistor value of 10k ohms are given in the table.

Direction (degrees)	Resistance (ohms)
0	33K
22.5	6.57K
45	8.2K
67.5	891
90	1K
112.5	688
135	2.2K
157.5	1.41K
180	3.9K
202.5	3.14K
225	16K
247.5	14.12K
270	120K
292.5	42.12K
315	64.9K
337.5	21.88K

表中给出了所有 16 个可能位置的电阻值。

The wind vane is the most complicated of the three sensors. It has eight switches, each connected to a different resistor. The vane's magnet may close two switches at once, allowing up



# Shenzhen Fine Offset Electronics Co., Ltd

## 深圳市欧赛特电子有限公司

Address: 4/F, Block C, Jiujiu Industrial City, Shajing Town, Bao'an District, Shenzhen City, China

---

to 16 different positions to be indicated . An external resistor can be used to form a voltage divider , producing a voltage output that can be measured with an analog to digital converter, as shown below.

The switch and resistor arrangement is shown in the diagram to the right. Resistance values for all 16 possible positions are given in the table.

Resistance values for positions between those shown in the diagram are the result of two adjacent resistors connected in parallel when the vane's magnet activates two switches simultaneously.