



HESTORE.HU

elektronikai alkatrész áruház

EN: This Datasheet is presented by the manufacturer.

Please visit our website for pricing and availability at www.hestore.hu.

High speed CAN transceiver

FEATURES

- Fully compatible with the “ISO 11898” standard
- High speed (up to 1 Mbaud)
- Transmit Data (TXD) dominant time-out function
- Bus lines protected against transients in an automotive environment
- Silent mode in which the transmitter is disabled
- Differential receiver with wide common-mode range for high ElectroMagnetic Immunity (EMI)
- Input levels compatible with 3.3 V devices
- Thermally protected
- Short-circuit proof to battery and ground
- An unpowered node does not disturb the bus lines
- At least 110 nodes can be connected.

GENERAL DESCRIPTION

The HGA1050 is the interface between the CAN protocol controller and the physical bus. The device provides differential transmit capability to the bus and differential receive capability to the CAN controller.

The HGA1050 is the successor to the PCA82C250 high speed CAN transceiver. The most important improvements are:

- Much lower ElectroMagnetic Emission (EME) due to optimal matching of the CANH and CANL output signals
- Improved behaviour in case of an unpowered node.

QUICK REFERENCE DATA

SYMBOL	PARAMETER	CONDITIONS	MIN.	MAX.	UNIT
V_{CC}	supply voltage		4.75	5.25	V
V_{CANH}	DC voltage at CANH	$0 < V_{CC} < 5.25$ V; no time limit	-27	+40	V
V_{CANL}	DC voltage at CANL				
$V_{i(dif)(bus)}$	differential bus input voltage	dominant	1.5	3	V
$t_{PD(TXD-RXD)}$	propagation delay TXD to RXD; see Fig.4	$V_S = 0$ V	-	250	ns
T_{amb}	operating ambient temperature		-40	+125	°C

BLOCK DIAGRAM

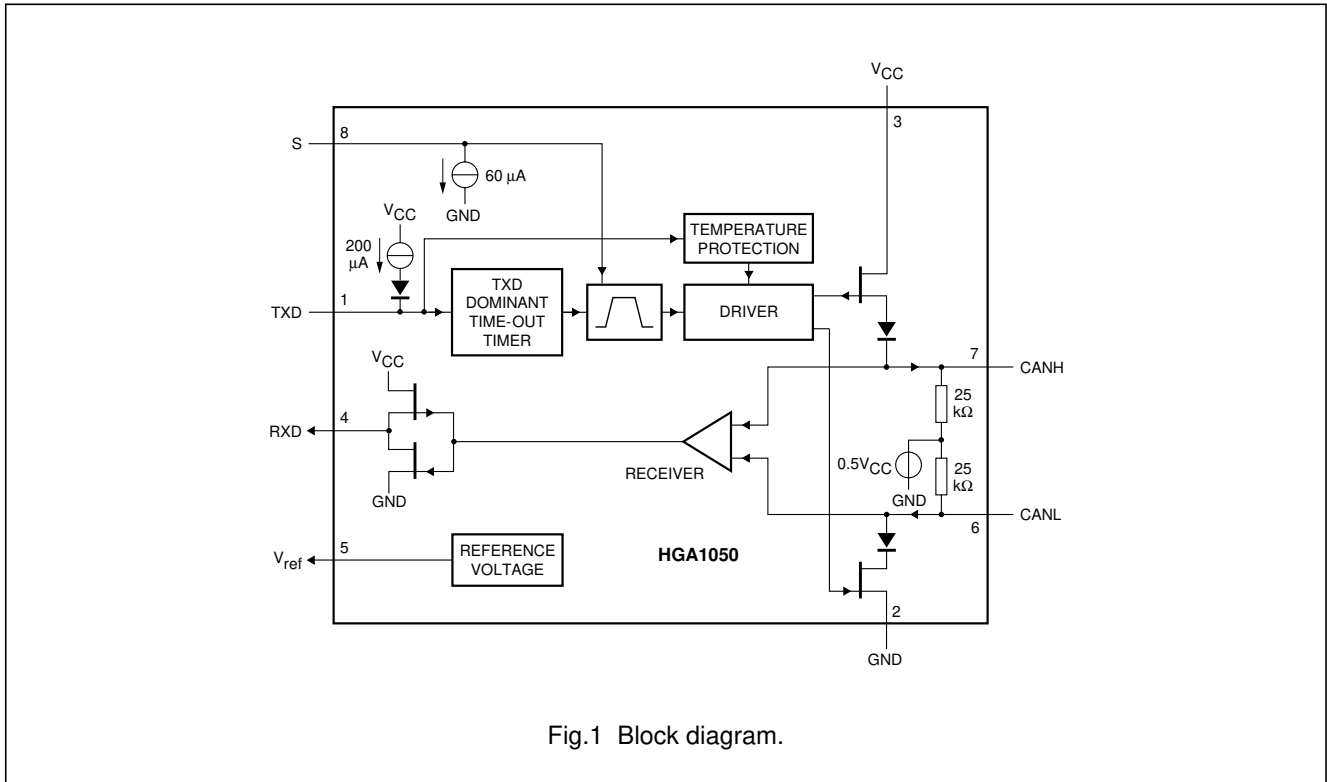

Fig.1 Block diagram.

PINNING

SYMBOL	PIN	DESCRIPTION
TXD	1	transmit data input; reads in data from the CAN controller to the bus line drivers
GND	2	ground
V _{CC}	3	supply voltage
RXD	4	receive data output; reads out data from the bus lines to the CAN controller
V _{ref}	5	reference voltage output
CANL	6	LOW-level CAN bus line
CANH	7	HIGH-level CAN bus line
S	8	select input for high speed mode/silent mode

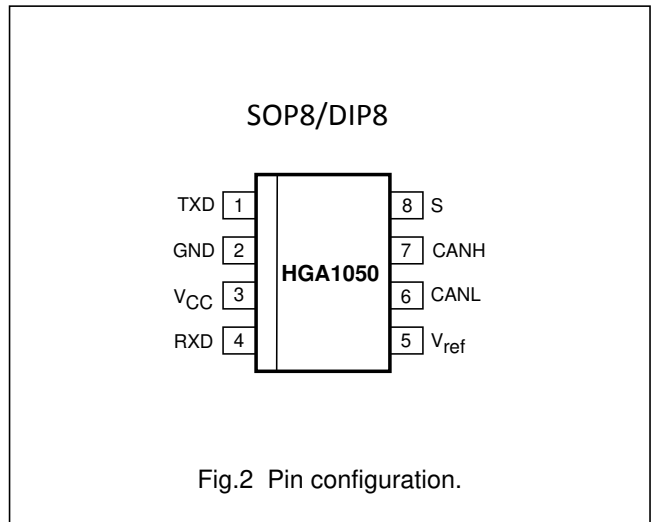

Fig.2 Pin configuration.

FUNCTIONAL DESCRIPTION

The HGA1050 is the interface between the CAN protocol controller and the physical bus. It is primarily intended for high speed automotive applications using baud rates from 40 kbaud up to 1 Mbaud. It provides differential transmit capability to the bus and differential receiver capability to the CAN protocol controller. It is fully compatible to the "ISO 11898" standard.

A current-limiting circuit protects the transmitter output stage from damage caused by accidental short-circuit to either positive or negative battery voltage, although power dissipation increases during this fault condition.

A thermal protection circuit protects the IC from damage by switching off the transmitter if the junction temperature exceeds a value of approximately 165 °C. Because the transmitter dissipates most of the power, the power dissipation and temperature of the IC is reduced. All other IC functions continue to operate. The transmitter off-state resets when TXD goes HIGH. The thermal protection circuit is particularly needed when a bus line short-circuits.

The CANH and CANL lines are protected from automotive electrical transients (according to "ISO 7637"; see Fig.6) and are also protected from Electro-Static-Discharge (ESD) of up to 4 kV from the human body.

Control line S (pin 8) allows two operating modes to be selected; high speed mode or silent mode.

High speed mode is the normal operating mode and is selected by connecting pin S to ground. It is the default mode if pin S is unconnected.

In the silent mode, the transmitter is disabled. All other IC functions continue to operate. The silent mode is selected by connecting pin S to V_{CC} .

A 'TXD Dominant Time-out' timer circuit prevents the bus lines being driven to a permanent dominant state (blocking all network communication) if TXD is forced permanently LOW by a hardware and/or software application failure. The timer is triggered by a negative edge on TXD. If the duration of the LOW-level on TXD exceeds the internal timer value, the transmitter is disabled, driving the bus into a recessive state. The timer is reset by a positive edge on TXD.

Table 1 Function table of the CAN transceiver
(X = don't care)

V_{CC}	TXD	S	CANH	CANL	BUS STATE	RXD
4.75 to 5.25 V	0	0 (or floating)	HIGH	LOW	dominant	0
4.75 to 5.25 V	X	1	$0.5 \times V_{CC}$	$0.5 \times V_{CC}$	recessive	1
4.75 to 5.25 V	1 (or floating)	X	$0.5 \times V_{CC}$	$0.5 \times V_{CC}$	recessive	1
<2 V (not powered)	X	X	$0 V < CANH < V_{CC}$	$0 V < CANL < V_{CC}$	recessive	X
$2 V < V_{CC} < 4.75 V$	>2 V	X	$0 V < CANH < V_{CC}$	$0 V < CANL < V_{CC}$	recessive	X

LIMITING VALUES

In accordance with the Absolute Maximum Rating System (IEC 134). All voltages are referenced to GND (pin 2). Positive currents flow into the IC.

SYMBOL	PARAMETER	CONDITIONS	MIN.	MAX.	UNIT
V_{CC}	supply voltage		-0.3	+5.25	V
V_{CANL} , V_{CANH}	DC voltage at CANL and CANH	$0 < V_{CC} < 5.25$ V; no time limit	-27	+40	V
V_{TXD} , V_{RXD} , V_{ref} and V_S	DC voltage at TXD, RXD, V_{ref} and S		-0.3	$V_{CC} + 0.3$	V
$V_{trt(CANH)}$, $V_{trt(CANL)}$	transient voltage at CANH and CANL	time limit is 1 μ s	-55	+55	V
		note 1	-200	+200	V
V_{esd}	electrostatic discharge at CANH; CANL	note 3	-4	+4	kV
	electrostatic discharge at TXD; V_{CC} ; RXD; V_{ref} and S	note 3	-2	+2	kV
	electrostatic discharge at all pins	note 4	-200	+200	V
T_{stg}	storage temperature		-55	+150	$^{\circ}$ C
T_{amb}	operating ambient temperature		-40	+125	$^{\circ}$ C
T_j	junction temperature	note 2	-40	+150	$^{\circ}$ C

Notes

- The waveforms of the applied transients shall be in accordance with "ISO 7637 part 1", test pulses 1, 2, 3a and 3b, (see Fig.6).
- In accordance with "IEC 747-1". An alternative definition of T_j is: $T_j = T_{amb} + P \times R_{th(j-a)}$, where $R_{th(j-a)}$ is a fixed value to be used for the calculation of T_j . The rating for T_j limits the allowable combinations of power dissipation (P) and ambient temperature (T_{amb}).
- Human body model; C = 100 pF R = 1.5 k Ω .
- Machine model; C = 200 pF R = 25 Ω .

THERMAL CHARACTERISTICS

According to IEC 747-1.

SYMBOL	PARAMETER	CONDITIONS	VALUE	UNIT
$R_{th(j-a)}$	thermal resistance from junction to ambient; HGA1050 (SOP8)	in free air	160	K/W

CHARACTERISTICS

$V_{CC} = 4.75$ to 5.25 V; $T_{amb} = -40$ to $+125$ °C; $R_L = 60$ Ω unless specified otherwise; all voltages are referenced to GND (pin 2); positive currents flow into the IC; all parameters are guaranteed over the ambient temperature range by design, but only 100% tested at $T_{amb} = 25$ °C unless specified otherwise.

SYMBOL	PARAMETER	CONDITIONS	MIN.	TYP.	MAX.	UNIT
Supply (V_{CC})						
I_{CC}	supply current	dominant; $V_{TXD} = 0$ V	tbf	–	75	mA
		recessive; $V_{TXD} = V_{CC}$	tbf	–	13	mA
Transmitter data input (TXD)						
V_{IH}	HIGH-level input voltage	output recessive	2.0	–	$V_{CC} + 0.3$	V
V_{IL}	LOW-level input voltage	output dominant	–0.3	–	+0.8	V
I_{IH}	HIGH-level input current	$V_{TXD} = V_{CC}$	–30	0	+30	μ A
I_{IL}	LOW-level input current	$V_{TXD} = 0$ V	–100	–200	–300	μ A
$C_{i(TXD)}$	TXD input capacitance	not tested	–	–	tbf	pF
Mode select input (S)						
V_{IH}	HIGH-level input voltage	silent mode	2.0	–	$V_{CC} + 0.3$	V
V_{IL}	LOW-level input voltage	high speed mode	–0.3	–	+0.8	V
I_{IH}	HIGH-level input current	$V_S = V_{CC}$	30	60	100	μ A
I_{IL}	LOW-level input current	$V_S = 0$ V	–30	0	+30	μ A
Receiver data output (RXD)						
I_{OH}	HIGH-level output current	$V_{RXD} = 0.7 V_{CC}$	tbf	tbf	tbf	mA
I_{OL}	LOW-level output current	$V_{RXD} = 0.45$ V	2	8.5	20	mA
V_{ref}						
V_{ref}	reference output voltage	$-50 \mu\text{A} < I_{Vref} < 50 \mu\text{A}$	$0.45V_{CC}$	$0.5V_{CC}$	$0.55V_{CC}$	V
Bus lines (CANH; CANL)						
$V_{CANH(reces)}$; $V_{CANL(reces)}$	recessive bus voltage	$V_{TXD} = V_{CC}$; no load	2.0	–	3.0	V
$I_{o(CANH)(reces)}$; $I_{o(CANL)(reces)}$	recessive output current	$-27 \text{ V} < V_{CANH}$; $V_{CANL} < 32 \text{ V}$; $0 \text{ V} < V_{CC} < 5.25 \text{ V}$	–2.5	–	+2.5	mA
$V_{o(CANH)}$	CANH dominant output voltage	$V_{TXD} = 0$ V	2.8	–	4.5	V
$V_{o(CANL)}$	CANL dominant output voltage		0.5	–	2.0	V
$V_{i(dif)(bus)}$	differential bus input voltage ($V_{CANH} - V_{CANL}$)	$V_{TXD} = 0$ V; $42.5 < R_L < 60 \Omega$ (dominant)	1.5	–	3.0	V
		$V_{TXD} = V_{CC}$; no load (recessive)	–500	–	+50	mV
$I_{o(sc)(CANH)}$	CANH short-circuit output current	$V_{CANH} = 0$ V; $V_{TXD} = 0$ V	–35	–	–95	mA
$I_{o(sc)(CANL)}$	CANL short-circuit output current	$V_{CANL} = 36$ V; $V_{TXD} = 0$ V	35	–	150	mA

SYMBOL	PARAMETER	CONDITIONS	MIN.	TYP.	MAX.	UNIT
$V_{dif(th)}$	differential receiver threshold voltage	$-12\text{ V} < V_{CANH}$, $V_{CANL} < 12\text{ V}$; see Fig.5	0.5	0.7	0.9	V
$V_{i(dif)(hys)}$	differential receiver input voltage hysteresis	see Fig.5	100	–	200	mV
$R_{i(cm)(CANH)}$; $R_{i(cm)(CANL)}$	CANH; CANL common mode input resistance		10	25	50	k Ω
$R_{i(cm)(m)}$	matching between CANH and CANL common mode input resistance	$V_{CANH} = V_{CANL}$	–3	–	+3	%
$R_{i(dif)}$	differential input resistance		20	50	100	k Ω
$C_{i(CANH)}$; $C_{i(CANL)}$	CANH; CANL input capacitance	$V_{TXD} = V_{CC}$; not tested	–	–	20	pF
$C_{i(dif)}$	differential input capacitance		–	–	10	pF
$I_{LI(CANH)}$; $I_{LI(CANL)}$	CANH; CANL input leakage current	$V_{CC} = 0\text{ V}$; $V_{CANH} = V_{CANL} = 5\text{ V}$	–	–	500	μA
Thermal shutdown						
$T_{j(sd)}$	shutdown junction temperature		155	165	180	$^{\circ}\text{C}$
Timing characteristics (see Figs 3 and 4)						
$t_{d(TXD-BUSon)}$	delay TXD to bus active	$V_S = 0\text{ V}$	tbf	tbf	150	ns
$t_{d(TXD-BUSoff)}$	delay TXD to bus inactive					
$t_{d(BUSon-RXD)}$	delay bus active to RXD		tbf	tbf	100	ns
$t_{d(BUSoff-RXD)}$	delay bus inactive to RXD					

TEST AND APPLICATION INFORMATION

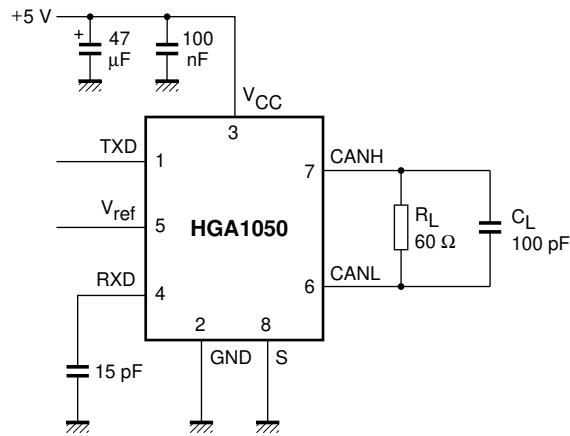
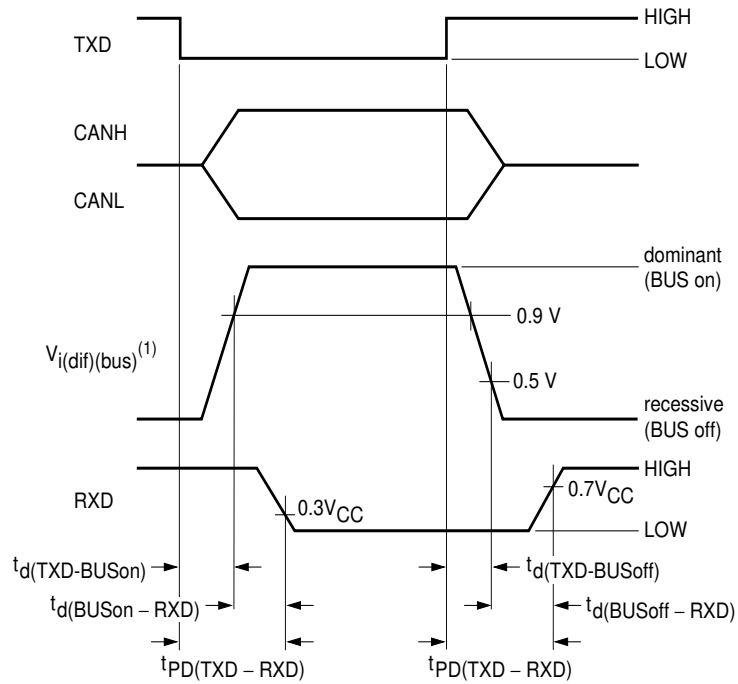

Fig.3 Test circuit for timing characteristics.



(1) $V_{i(dif)(bus)} = V_{CANH} - V_{CANL}$

Fig.4 Timing diagram for AC characteristics.

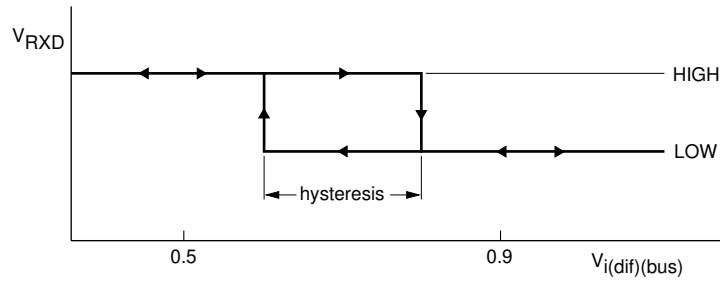

Fig.5 Hysteresis of the receiver.

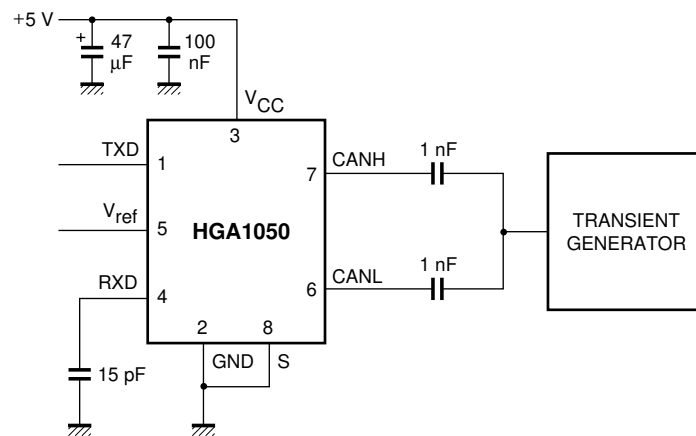

Fig.6 Test circuit for automotive transients.

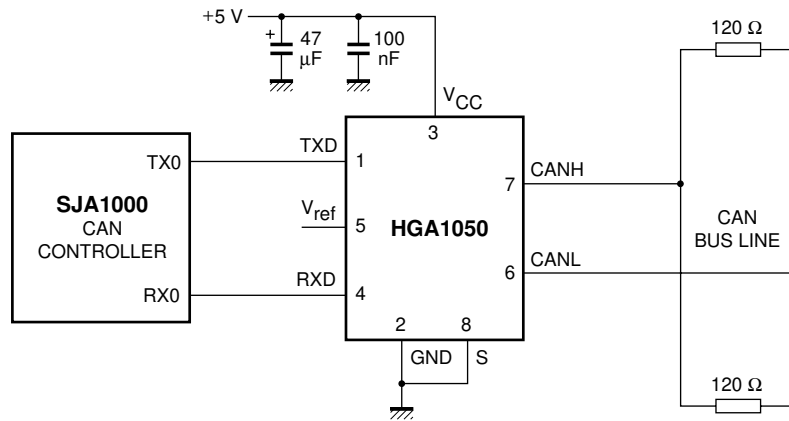

Fig.7 Application information.

PACKAGE

SOP8

UNIT: mm							
DIM.	MIN	TYP	MAX	DIM.	MIN	TYP	MAX
A	4.520	4.570	4.620	a	0.400	0.420	0.440
A1	0.100	-	0.250	b	1.260	1.270	1.280
B	4.800	4.920	5.100	Q	0°	-	8°
C	5.800	6.100	6.250				
C1	3.800	3.900	4.000				
D	0.400	-	0.950				

DIP8

UNIT: mm							
DIM.	MIN	TYP	MAX	DIM.	MIN	TYP	MAX
A	6.100	6.300	6.680	a	1.504	1.524	1.544
B	9.000	9.200	9.500	b	-	0.889	-
D	8.400	8.700	9.000	c	0.437	0.457	0.477
D1	7.42	7.62	7.82	d	2.530	2.540	2.550
E	3.100	3.300	3.550	L	0.500	-	0.700
				L1	3.000	3.200	3.600

Important statement:

Huaguan Semiconductor Co,Ltd. reserves the right to change the products and services provided without notice. Customers should obtain the latest relevant information before ordering, and verify the timeliness and accuracy of this information.

Customers are responsible for complying with safety standards and taking safety measures when using our products for system design and machine manufacturing to avoid potential risks that may result in personal injury or property damage.

Our products are not licensed for applications in life support, military, aerospace, etc., so we do not bear the consequences of the application of these products in these fields.

Our documentation is only permitted to be copied without any tampering with the content, so we do not accept any responsibility or liability for the altered documents.