



HESTORE.HU

elektronikai alkatrész áruház

EN: This Datasheet is presented by the manufacturer.

Please visit our website for pricing and availability at www.hestore.hu.

Solenoid valve(5/2 way, 5/3 way)

4V100 Series



Symbol

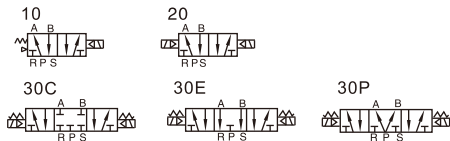

Product feature

- Pilot-oriented mode: Internal pilot or external pilot.
- Structure in sliding column mode: good tightness and sensitive reaction .
- Three position solenoid valves have three kinds of central function for your choice.
- Double control solenoid valves have memory function.
- Internal hole adopts special processing technology which has little attrition friction, low start pressure and long service life.
- No need to add oil for lubrication.
- It is available to form integrated valve group with the base to save installation space.
- Affiliated manual devices are equipped to facilitate installation and debugging.
- Several standard voltage grades are optional.

Ordering code

Specification

Model	4V110-M5 4V120-M5	4V130C-M5 4V130E-M5 4V130P-M5	4V110-06 4V120-06	4V130C-06 4V130E-06 4V130P-06
Fluid	Air(to be filtered by 40 μ m filter element)			
Acting	Internal pilot or external pilot			
Port size [Note1]	In=Out=M5		In=Out=1/8"	
Orifice size(Cv) [Note4]	4V110-06,4V120-06:10.2mm ² (Cv=0.6) 4V130C-06:8.6mm ² (Cv=0.51)			
Valve type	5 port 2 position	5 port 3 position	5 port 2 position	5 port 3 position
Operating pressure	0.15~0.8MPa(21~114psi)			
Proof pressure	1.2MPa(175psi)			
Temperature	-20~70°C			
Material of body	Aluminum alloy			
Lubrication [Note2]	Not required			
Max.frequency [Note3]	5 cycle/sec	3cycle/sec	5 cycle/sec	3 cycle/sec
Weight (g)	4V110-M5:120 4V120-M5:175	200	4V110-06:120 4V120-06:175	200

[Note1] G thread is available.

[Note2] Once lubricated air is used, continue with same medium to optimise valve life span. Lubricants like ISO VG32 or equivalent are recommended.

[Note3] The maximum actuation frequency is in the no-load state.

[Note4] Equivalent orifice S and Cv are all calculated from the flow rate data.

Coil specification

Item	specification				
Standard voltage	AC220V	AC110V	AC24V	DC24V	DC12V
Scope of voltage	AC: ± 15% DC: ± 10%				
Power consumption	3.5VA	3.5VA	4.0VA	2.5W	2.5W
Protection	IP65(DIN40050)				
Temperature classification	B Class				
Electrical entry	Terminal, Grommet				
Activating time	0.05 sec and below				

4V 1 10 06 A □ G



① Model	② Code	③ Valve type	④ Port size	⑤ Voltage	⑥ Electrical entry	⑦ Thread type
4V: Solenoid valve (5/2, 5/3 way)	1: 100 Series	10: Single solenoid 5/2 way 20: Double solenoid 5/2 way 30C: Double solenoid 5/3 way closed center	M5: M5	A: AC220V B: DC24V C: AC110V E: AC24V F: DC12V	Blank: Terminal I: Grommet[Note]	No this code
		30E: Double solenoid 5/3 way exhaust center 30P: Double solenoid 5/3 way pressure center	06: 1/8"			G: G Thread

[Note] The wire length is 5m. Please refer to 79 for manifold specification and the order way.

Flow chart

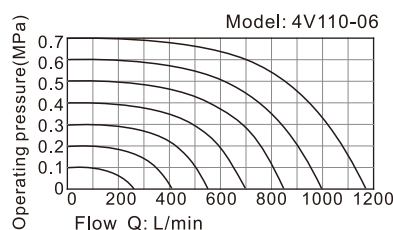

The data in flow rate chart are obtained from AirTAC lab.

Solenoid valve(5/2 way,5/3 way)

4V100 Series

Inner structure

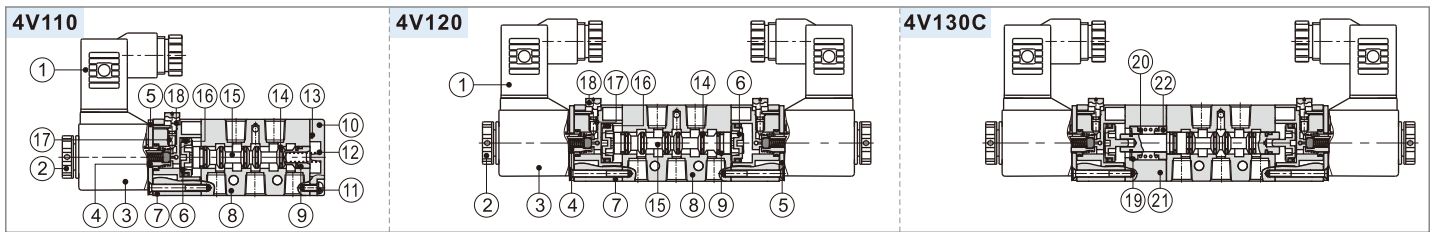

No.	Item	No.	Item	No.	Item	No.	Item	No.	Item	No.	Item	No.	Item	No.	Item	No.	Item	No.	Item	No.	Item
1	Connector	3	Coil	5	Fixed plate	7	Pilot kit	9	Wear ring	11	Fixed screw	13	Bottom cover gasket	15	Spool	17	Override spring	19	Spring holder	21	Side cover
2	Coil net	4	Armature	6	Piston	8	Body	10	Bottom cover	12	Spool spring	14	Spool O-ring	16	Piston O-ring	18	Manual override	20	Return spring	22	Spring holder

Dimensions

4V110(Terminal)

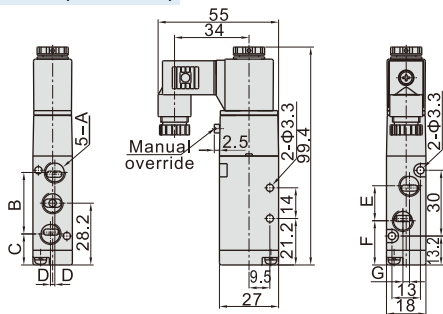

4V110(Grommet)

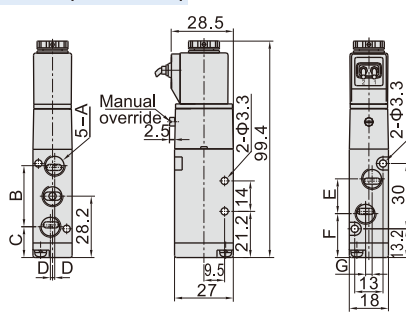

Model\Item	A	B	C	D	E	F	B
4V110-M5	M5x0.8	27	14.7	0	14	21.2	0
4V110-06	1/8"	28	14.2	1	16	20.2	3

4V120(Terminal)

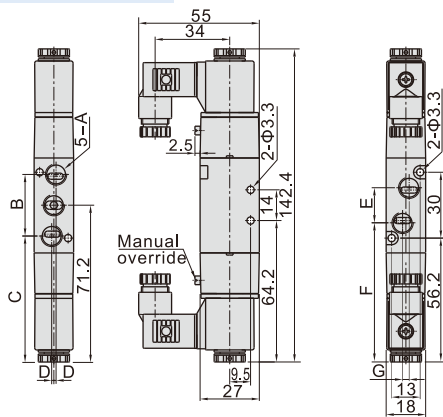

4V120(Grommet)

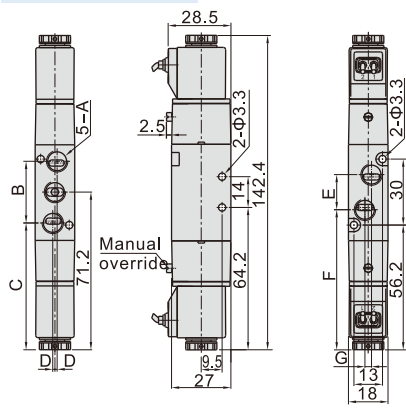

Model\Item	A	B	C	D	E	F	G
4V120-M5	M5x0.8	27	57.7	0	14	64.3	0
4V120-06	1/8"	28	57.2	1	16	63.2	3

4V130(Terminal)

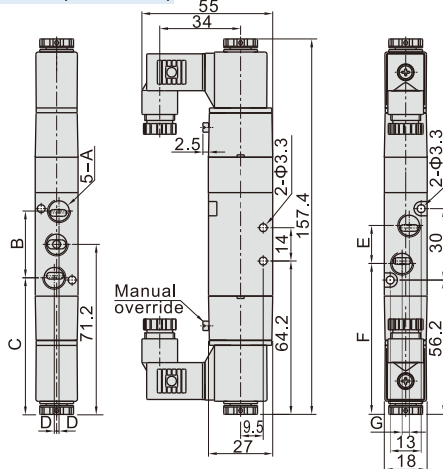

4V130(Grommet)

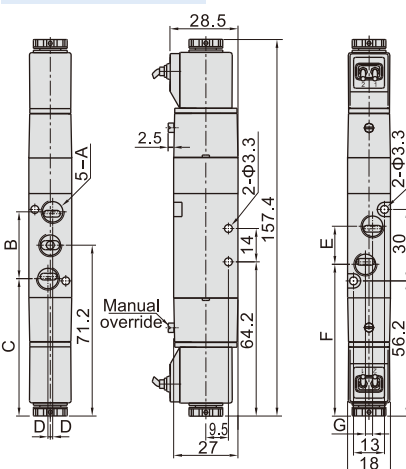

Model\Item	A	B	C	D	E	F	G
4V130-M5	M5x0.8	27	57.7	0	14	64.3	0
4V130-06	1/8"	28	57.2	1	16	63.2	3

Solenoid valve(5/2 way, 5/3 way)

4V200 Series



Symbol

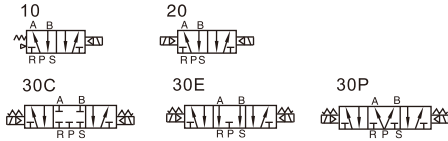

Product feature

1. Pilot-oriented mode: Internal pilot or external pilot.
2. Structure in sliding column mode: good tightness and sensitive reaction.
3. Three position solenoid valves have three kinds of central function for your choice.
4. Double control solenoid valves have memory function.
5. Internal hole adopts special processing technology which has little attrition friction, low start pressure and long service life.
6. No need to add oil for lubrication.
7. It is available to form integrated valve group with the base to save installation space.
8. Affiliated manual devices are equipped to facilitate installation and debugging.
9. Several standard voltage grades are optional.

specification

Model	4V210-06 4V220-06	4V230C-06 4V230E-06 4V230P-06	4V210-08 4V220-08	4V230C-08 4V230E-08 4V230P-08
Fluid	Air(to be filtered by 40 μm filter element)			
Acting	Internal pilot or external pilot			
Port size [Note1]	In=Out=Exhaust=1/8"		In=Out=1/4" Exhaust=1/8"	
Orifice size(Cv) [Note4]	4V210-08,4V220-08:17.0mm ² (Cv=1.0) 4V230C-08:13.6mm ² (Cv=0.8)			
Valve type	5 port 2 position	5 port 3 position	5 port 2 position	5 port 3 position
Operating pressure	0.15~0.8MPa(21~114psi)			
Operating pressure	1.2MPa(175psi)			
Temperature	-20~70°C			
Material of body	Aluminum alloy			
Lubrication [Note2]	Not required			
Max. frequency [Note3]	5 cycle/sec	3 cycle/sec	5 cycle/sec	3 cycle/sec
Weight (g)	4V210-06:220 4V220-06:320	360	4V210-08:220 4V220-08:320	360

[Note1] G thread is available.

[Note2] Once lubricated air is used, continue with same medium to optimise valve life span. Lubricants like ISO VG32 or equivalent are recommended.

[Note3] The maximum actuation frequency is in the no-load state.

[Note4] Equivalent orifice S and Cv are all calculated from the flow rate data.

Coil specification

Item	specification				
Standard voltage	AC220V	AC110V	AC24V	DC24V	DC12V
Scope of voltage	AC: ± 15% DC: ± 10%				
Power consumption	4.5VA	4.5VA	5.0VA	3.0W	3.0W
Protection	IP65(DIN40050)				
Temperature classification	B Class				
Electrical entry	Terminal, Grommet				
Activating time	0.05 sec and below				

Ordering code

4V 2 10 08 A □ G



① Model	② Code	③ Valve type	④ Port size	⑤ Voltage	⑥ Electrical entry	⑦ Thread type
4V: Solenoid valve (5/2, 5/3 way)	2: 200 Series	10: Single solenoid 5/2 way 20: Double solenoid 5/2 way 30C: Double solenoid 5/3 way closed center 30E: Double solenoid 5/3 way exhaust center 30P: Double solenoid 5/3 way pressure center	06: 1/8" 08: 1/4"	A: AC220V B: DC24V C: AC110V E: AC24V F: DC12V	Blank: Terminal I: Grommet[Note]	G: G Thread

[Note] The wire length is 5m. Please refer to 79 for manifold specification and the order way.

Flow chart

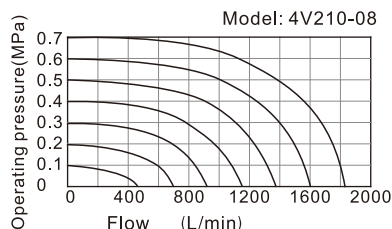

The data in flow rate chart are obtained from AirTAC lab.

Solenoid valve(5/2 way, 5/3 way)

4V200 Series

Inner structure

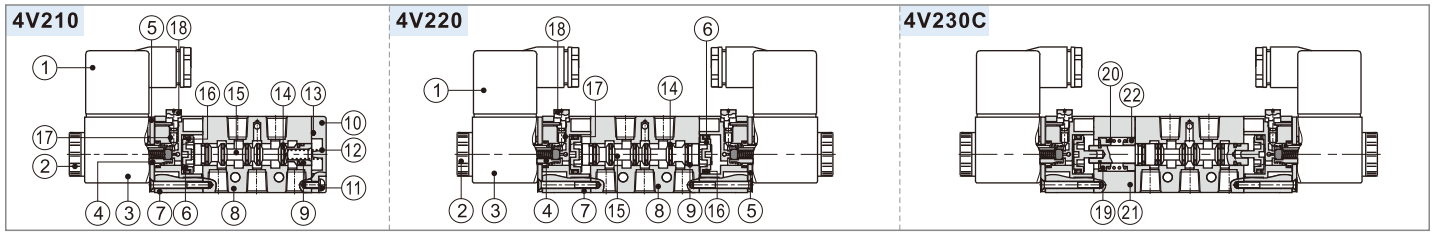

No.	Item	No.	Item	No.	Item	No.	Item	No.	Item	No.	Item	No.	Item	No.	Item	No.	Item	No.	Item	No.	Item
1	Connector	3	Coil	5	Fixed plate	7	Pilot kit	9	Wear ring	11	Fixed screw	13	Bottom cover gasket	15	Spool	17	Override spring	19	Spring holder	21	Side cover
2	Coil net	4	Armature	6	Piston	8	Body	10	Bottom cover	12	Spool spring	14	Spool O-ring	16	Piston O-ring	18	Manual override	20	Return spring	22	Spring holder

Dimensions

4V210(Terminal)

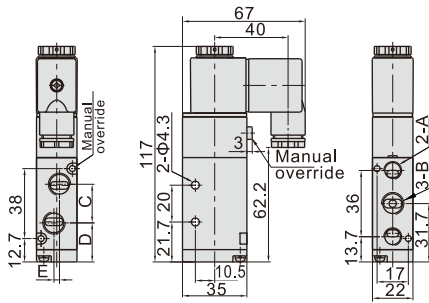

4V210(Grommet)

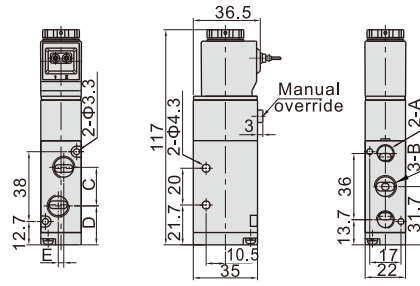

Model\Item	A	B	C	D	E
4V210-06	1/8"	1/8"	18	22.7	0
4V210-08	1/8"	1/4"	21	21.2	3

4V220(Terminal)

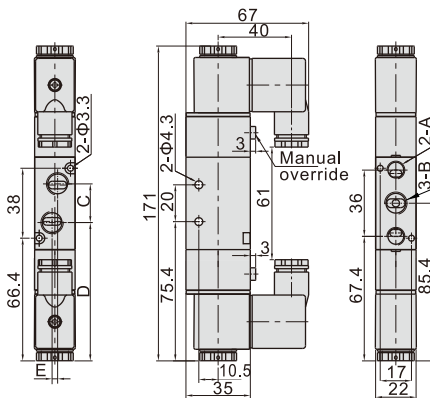

4V220(Grommet)

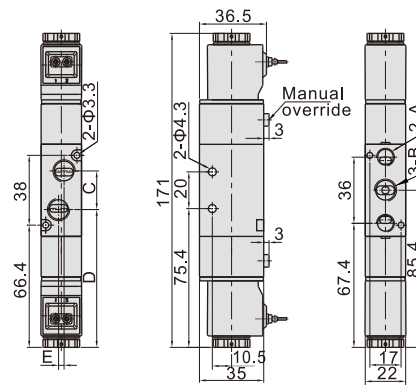

Model\Item	A	B	C	D	E
4V220-06	1/8"	1/8"	18	76.4	0
4V220-08	1/8"	1/4"	21	74.9	3

4V230(Terminal)

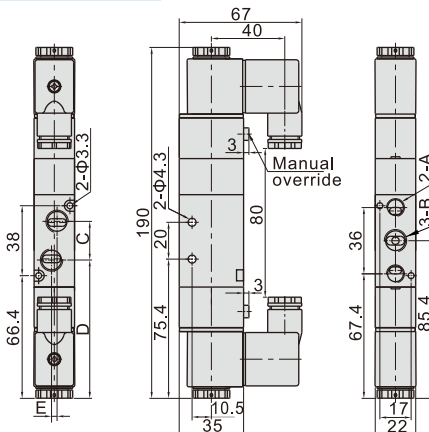

4V230(Grommet)

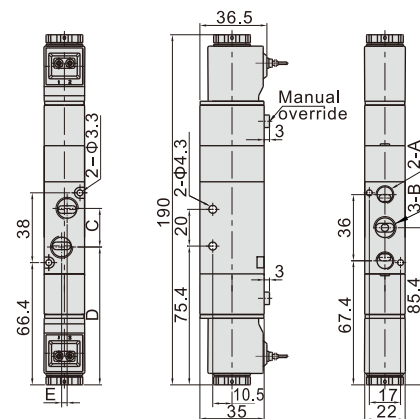

Model\Item	A	B	C	D	E
4V230-06	1/8"	1/8"	18	76.4	0
4V230-08	1/8"	1/4"	21	74.9	3

Solenoid valve(5/2 way, 5/3 way)

4V300 Series



Symbol

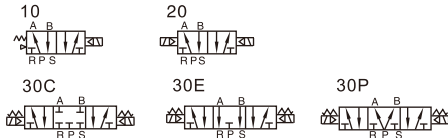

Product feature

1. Pilot-oriented mode: Internal pilot or external pilot.
2. Structure in sliding column mode: good tightness and sensitive reaction.
3. Three position solenoid valves have three kinds of central function for your choice.
4. Double control solenoid valves have memory function.
5. Internal hole adopts special processing technology which has little attrition friction, low start pressure and long service life.
6. No need to add oil for lubrication.
7. It is available to form integrated valve group with the base to save installation space.
8. Affiliated manual devices are equipped to facilitate installation and debugging.
9. Several standard voltage grades are optional.

Specification

Model	4V310-08 4V320-08	4V330C-08 4V330E-08 4V330P-08	4V310-10 4V320-10	4V330C-10 4V330E-10 4V330P-10
Fluid	Air(to be filtered by 40 μm filter element)			
Acting	Internal pilot or external pilot			
Port size [Note1]	In=Out=Exhaust=1/4"		In=Out=3/8" Exhaust=1/4"	
Orifice size(Cv) [Note4]	4V310-10,4V320-10:28.0mm ² (Cv=1.65) 4V330C-10:21.3mm ² (Cv=1.25)			
Valve type	5 port 2 position	5 port 3 position	5 port 2 position	5 port 3 position
Operating pressure	0.15~0.8MPa(21~114psi)			
Proof pressure	1.2MPa(175psi)			
Temperature	-20~70°C			
Material of body	Aluminum alloy			
Lubrication [Note2]	Not required			
Max.frequency [Note3]	4 cycle/sec	3 cycle/sec	4 cycle/sec	3 cycle/sec
Weight (g)	4V310-08:310 4V320-08:400	450	4V310-10:310 4V320-10:400	450

[Note1] G thread is available.

[Note2] Once lubricated air is used, continue with same medium to optimise valve life span. Lubricants like ISO VG32 or equivalent are recommended.

[Note3] The maximum actuation frequency is in the no-load state.

[Note4] Equivalent orifice S and Cv are all calculated from the flow rate data.

Coil specification

Item	specification				
Standard voltage	AC220V	AC110V	AC24V	DC24V	DC12V
Scope of voltage	AC: ±15% DC: ±10%				
Power consumption	4.5VA	4.5VA	5.0VA	3.0W	3.0W
Protection	IP65(DIN40050)				
Temperature classification	B Class				
Electrical entry	Terminal, Grommet				
Activating time	0.05 sec and below				

Ordering code

4V 3 10 10 A □ G



① Model	② Code	③ Valve type	④ Port size	⑤ Voltage	⑥ Electrical entry	⑦ Thread type
4V: Solenoid valve (5/2, 5/3 way)	3: 300 Series	10: Single solenoid 5/2 way 20: Double solenoid 5/2 way 30C: Double solenoid 5/3 way closed center 30E: Double solenoid 5/3 way exhaust center 30P: Double solenoid 5/3 way pressure center	08: 1/4" 10: 3/8"	A: AC220V B: DC24V C: AC110V E: AC24V F: DC12V	Blank: Terminal I: Grommet[Note]	G: G Thread

[Note] The wire length is 5m. Please refer to 79 for manifold specification and the order way.

Flow chart

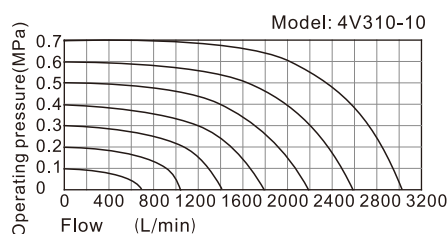

The data in flow rate chart are obtained from AirTAC lab.

Solenoid valve(5/2 way,5/3 way)

4V300 Series

Inner structure

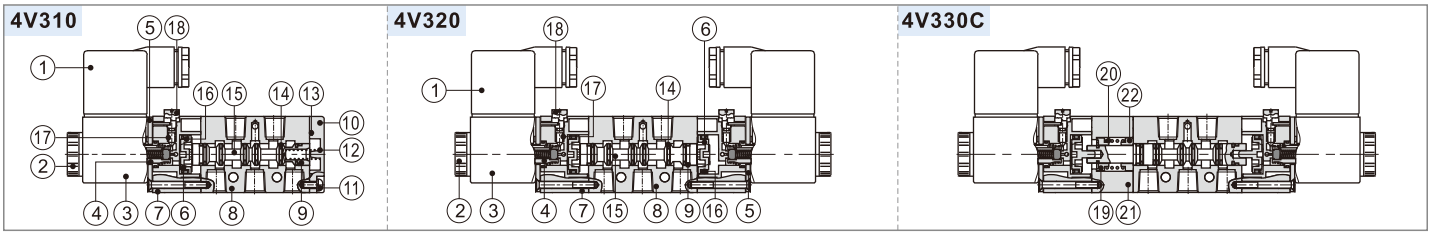

No.	Item	No.	Item	No.	Item	No.	Item	No.	Item	No.	Item	No.	Item	No.	Item	No.	Item	No.	Item	No.	Item
1	Connector	3	Coil	5	Fixed plate	7	Pilot kit	9	Wear ring	11	Fixed screw	13	Bottom cover gasket	15	Spool	17	Override spring	19	Spring holder	21	Side cover
2	Coil net	4	Armature	6	Piston	8	Body	10	Bottom cover	12	Spool spring	14	Spool O-ring	16	Piston O-ring	18	Manual override	20	Return spring	22	Spring holder

Dimensions

4V310(Terminal)

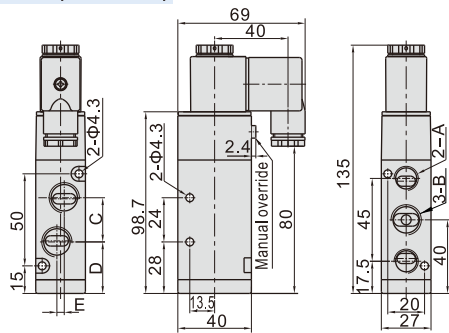

4V310(Grommet)

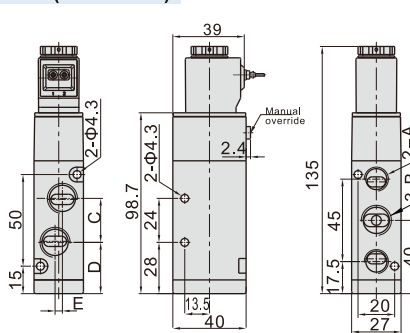

Model/Item	A	B	C	D	E
4V310-08	1/4"	1/4"	22	29	0
4V310-10	1/4"	3/8"	24	28	4

4V320(Terminal)

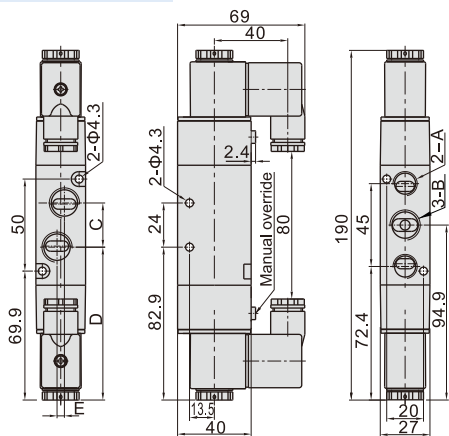

4V320(Grommet)

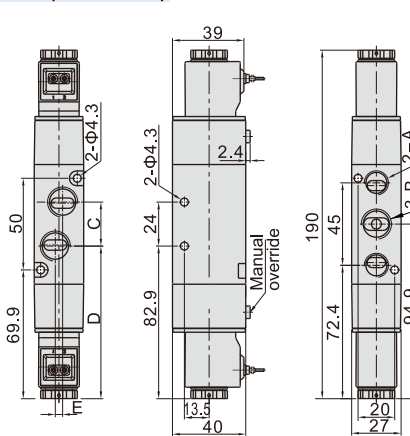

Model/Item	A	B	C	D	E
4V320-08	1/4"	1/4"	22	83.9	0
4V320-10	1/4"	3/8"	24	82.9	4

4V330(Terminal)

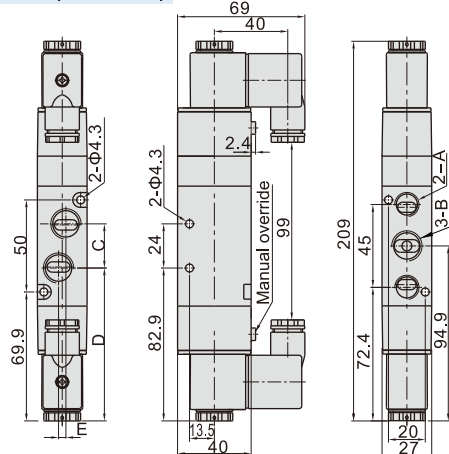

4V330(Grommet)

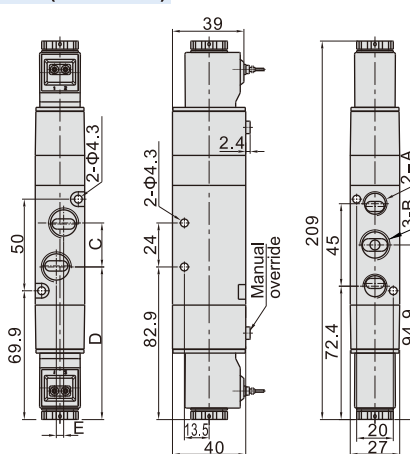

Model/Item	A	B	C	D	E
4V330-08	1/4"	1/4"	22	83.9	0
4V330-10	1/4"	3/8"	24	82.9	4



Solenoid valve(5/2 way, 5/3 way)

4V400 Series



Symbol

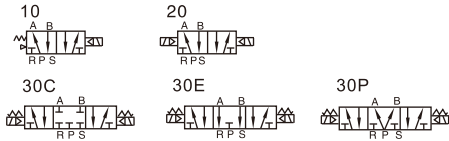

Product feature

1. Pilot-oriented mode: Internal pilot or external pilot.
2. Structure in sliding column mode: good tightness and sensitive reaction.
3. Three position solenoid valves have three kinds of central function for your choice.
4. Double control solenoid valves have memory function.
5. Internal hole adopts special processing technology which has little attrition friction, low start pressure and long service life.
6. No need to add oil for lubrication.
7. It is available to form integrated valve group with the base to save installation space.
8. Affiliated manual devices are equipped to facilitate installation and debugging.
9. Several standard voltage grades are optional.

Ordering code

Specification

Model	4V410-15	4V420-15	4V430C-15	4V430E-15	4V430P-15
Fluid	Air(to be filtered by 40 μm filter element)				
Acting	Internal pilot or external pilot				
Port size [Note1]	In=Out=Exhaust=1/2"				
Orifice size(Cv) [Note4]	4V410-15,4V420-15:48.0mm ² (Cv=2.82) 4V430C-15:40.0mm ² (Cv=2.35)				
Valve type	5 port 2 position		5 port 3 position		
Operating pressure	0.15~0.8MPa(21~114psi)				
Proof pressure	1.2MPa(175psi)				
Temperature	-20~70℃				
Material of body	Aluminum alloy				
Lubrication [Note2]	Not required				
Max. frequency [Note3]	3 cycle/sec				
Weight (g)	590	720			770

[Note1] G thread is available.

[Note2] Once lubricated air is used, continue with same medium to optimise valve life span. Lubricants like ISO VG32 or equivalent are recommended.

[Note3] The maximum actuation frequency is in the no-load state.

[Note4] Equivalent orifice S and Cv are all calculated from the flow rate data.

Coil specification

Item	specification				
Standard voltage	AC220V	AC110V	AC24V	DC24V	DC12V
Scope of voltage	AC: ± 15% DC: ± 10%				
Power consumption	4.5VA	4.5VA	5.0VA	3.0W	3.0W
Protection	IP65(DIN40050)				
Temperature classification	B Class				
Electrical entry	Terminal, Grommet				
Activating time	0.05 sec and below				

4V 4 10 15 A □ G



① Model	② Code	③ Valve type	④ Port size	⑤ Voltage	⑥ Electrical entry	⑦ Thread type
4V: Solenoid valve (5/2, 5/3 way)	4: 400 Series	10: Single solenoid 5/2 way 20: Double solenoid 5/2 way 30C: Double solenoid 5/3 way closed center 30E: Double solenoid 5/3 way exhaust center 30P: Double solenoid 5/3 way pressure center	15: 1/2"	A: AC220V B: DC24V C: AC110V E: AC24V F: DC12V	Blank: Terminal I: Grommet[Note]	G: G Thread

[Note] The wire length is 5m. Please refer to 79 for manifold specification and the order way.

Flow chart

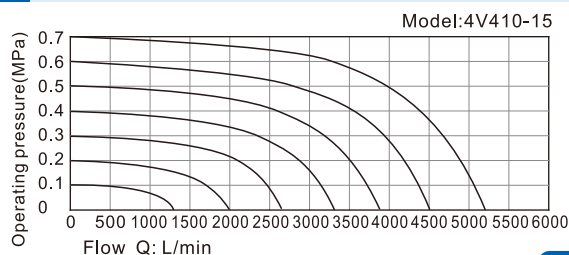

The data in flow rate chart are obtained from AirTAC lab.

Solenoid valve(5/2 way,5/3 way)

4V400 Series

Inner structure

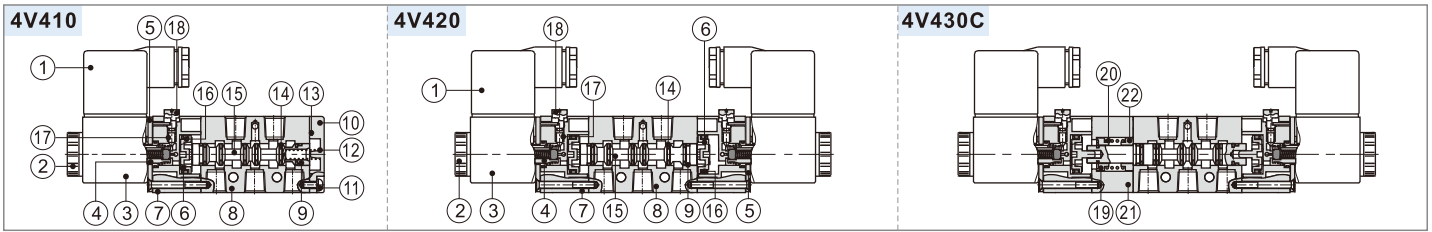

No.	Item	No.	Item	No.	Item	No.	Item	No.	Item	No.	Item	No.	Item	No.	Item	No.	Item	No.	Item	No.	Item
1	Connector	3	Coil	5	Fixed plate	7	Pilot kit	9	Wear ring	11	Fixed screw	13	Bottom cover gasket	15	Spool	17	Override spring	19	Spring holder	21	Side cover
2	Coil net	4	Armature	6	Piston	8	Body	10	Bottom cover	12	Spool spring	14	Spool O-ring	16	Piston O-ring	18	Manual override	20	Return spring	22	Spring holder

Dimensions

4V410(Terminal)

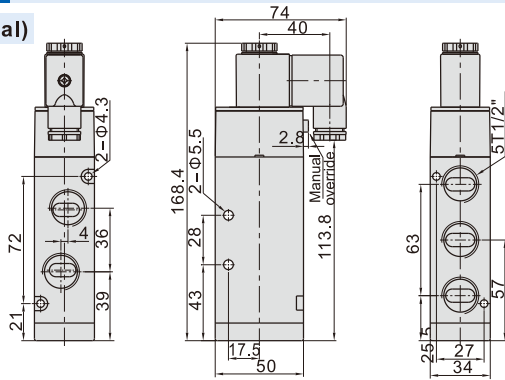

4V410(Grommet)

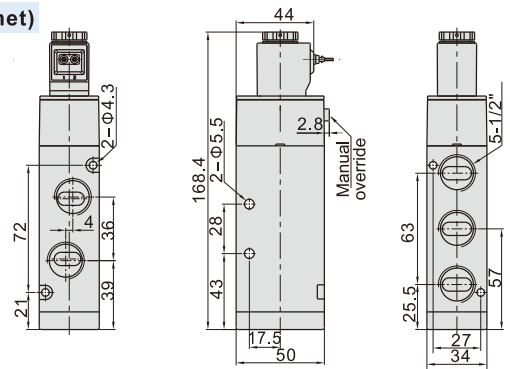

4V420(Terminal)

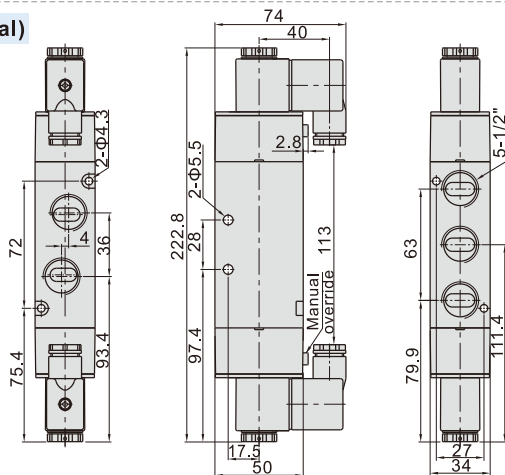

4V420(Grommet)

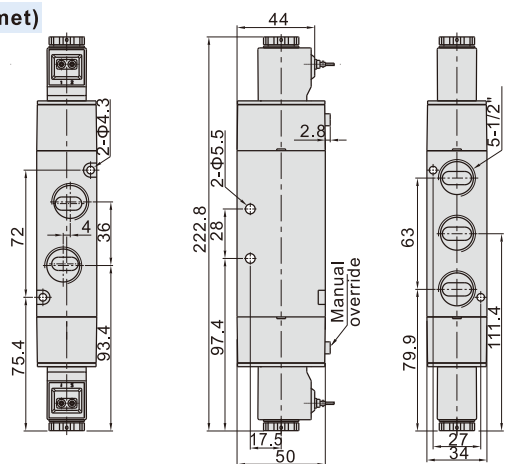

4V430(Terminal)

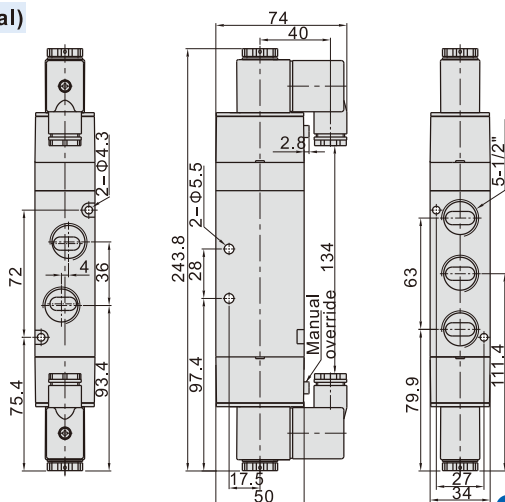

4V430(Grommet)

