



HESTORE.HU

elektronikai alkatrész áruház

EN: This Datasheet is presented by the manufacturer.

Please visit our website for pricing and availability at www.hestore.hu.

16 Channel Constant Current LED Driver with Ghosting Elimination

Features

- 16 constant-current output channels
- Constant output current invariant to load voltage change:
Constant output current range:
1-25mA@V_{DD}=5V;
1-10mA@V_{DD}=3.3V
- Excellent output current accuracy:
between channels: ±1.5% (typ.) and ±2.5% (max.)
between ICs: ±1.5% (typ.) and ±3% (max.)
- Output current adjusted through an external resistor
- Fast response of output current, \overline{OE} (min.): 50ns with good uniformity
between output channels
- Integrating ghosting elimination
- Staggered delay of output
- 25MHz clock frequency
- Schmitt trigger input
- 3.3V/ 5V supply voltage
- "Pb-free & Green" Package

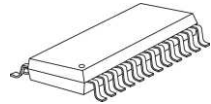
Small Outline Package

GF: SOP24L-300-1.00

Shrink SOP

GP: SSOP24L-150-0.64

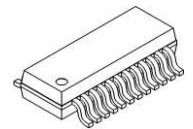
Mini SSOP

GM: mSSOP24L-100-0.5

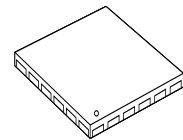
Quad Flat No-Lead

GFN: QFN24L-4*4-0.5

Product Description

With PrecisionDrive™ technology, MBI5124 is designed for LED displays which require to operate at low current and to match the luminous intensity of each channel. It provides supply voltage and accepts CMOS logic input at 3.3V and 5.0V to meet the trend of low power consumption. MBI5124 contains a serial buffer and data latches which convert serial input data into parallel output format. At MBI5124 output stage, sixteen regulated current ports are designed to provide uniform and constant current sinks for driving LEDs within a large range of V_F variations. Besides, MBI5124 integrates the pre-charge circuit which can relieve the ghosting.

MBI5124 provides users with great flexibility and device performance while using MBI5124 in their system design for LED display applications, e.g. LED panels. It accepts an input voltage range from 3.3V to 5V and maintains a constant current up from 1mA to 25mA determined by an external resistor, R_{ext} , which gives users flexibility in controlling the light intensity of LEDs. MBI5124 guarantees to endure maximum 17V at the output port. The high clock frequency, 25 MHz, also satisfies the system requirements of high volume data transmission.

Block Diagram

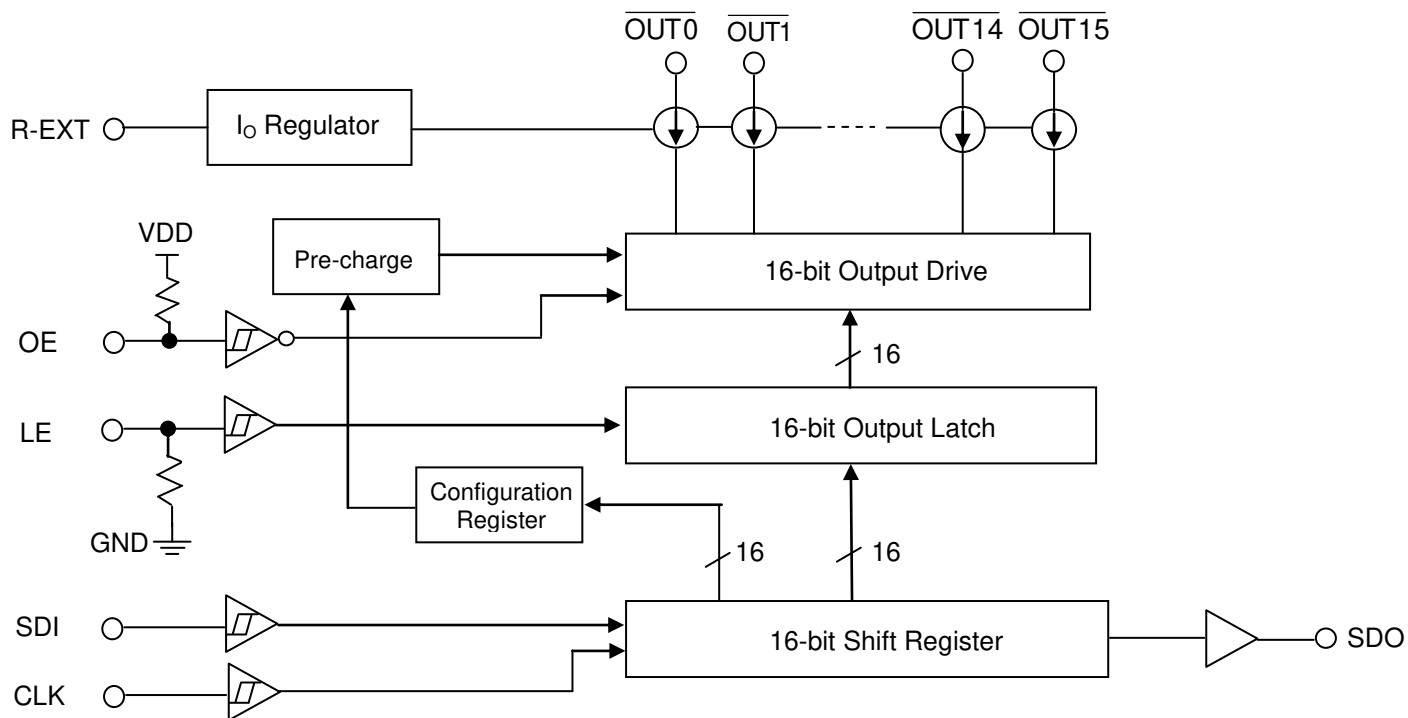

Pin Configuration

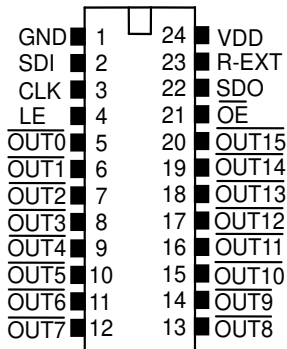

MBI5124GF/GP/GM

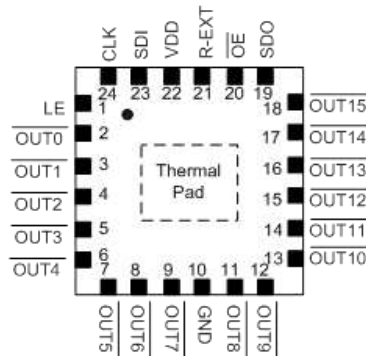

MBI5124GFN

Terminal Description

Pin Name	Function
GND	Ground terminal for control logic and current sink
SDI	Serial-data input to the shift register
CLK	Clock input terminal for data shift on rising edge
LE	Data strobe input terminal Serial data is transferred to the output latch when LE is high. The data is latched when LE goes low.
OUT0~OUT15	Constant current output terminals
OE	Output enable terminal When (active) low, the output drivers are enabled; when high, all output drivers are turned OFF (blanked).
SDO	Serial-data output to the following SDI of next driver IC. SDO signal change on rising edge of CLK.
R-EXT	Input terminal used to connect an external resistor for setting up output current for all output channels
VDD	3.3V/5V supply voltage terminal

Equivalent Circuits of Inputs and Outputs

\overline{OE} terminal

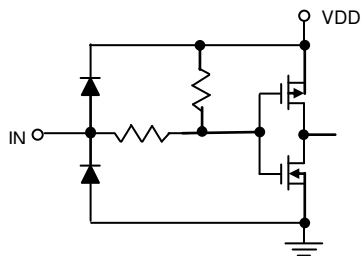

LE terminal

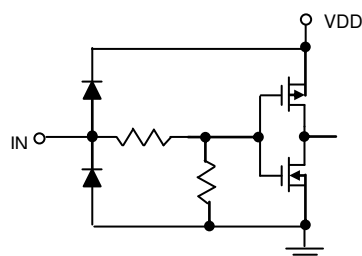

CLK, SDI terminal

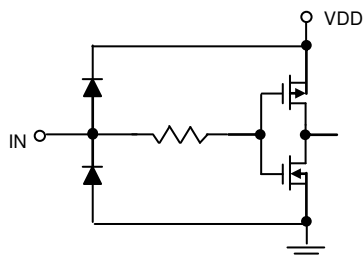

SDO terminal

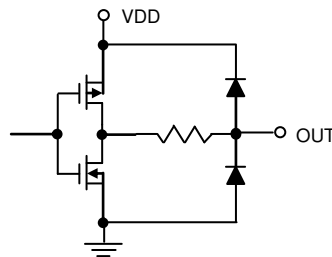

Timing Diagram

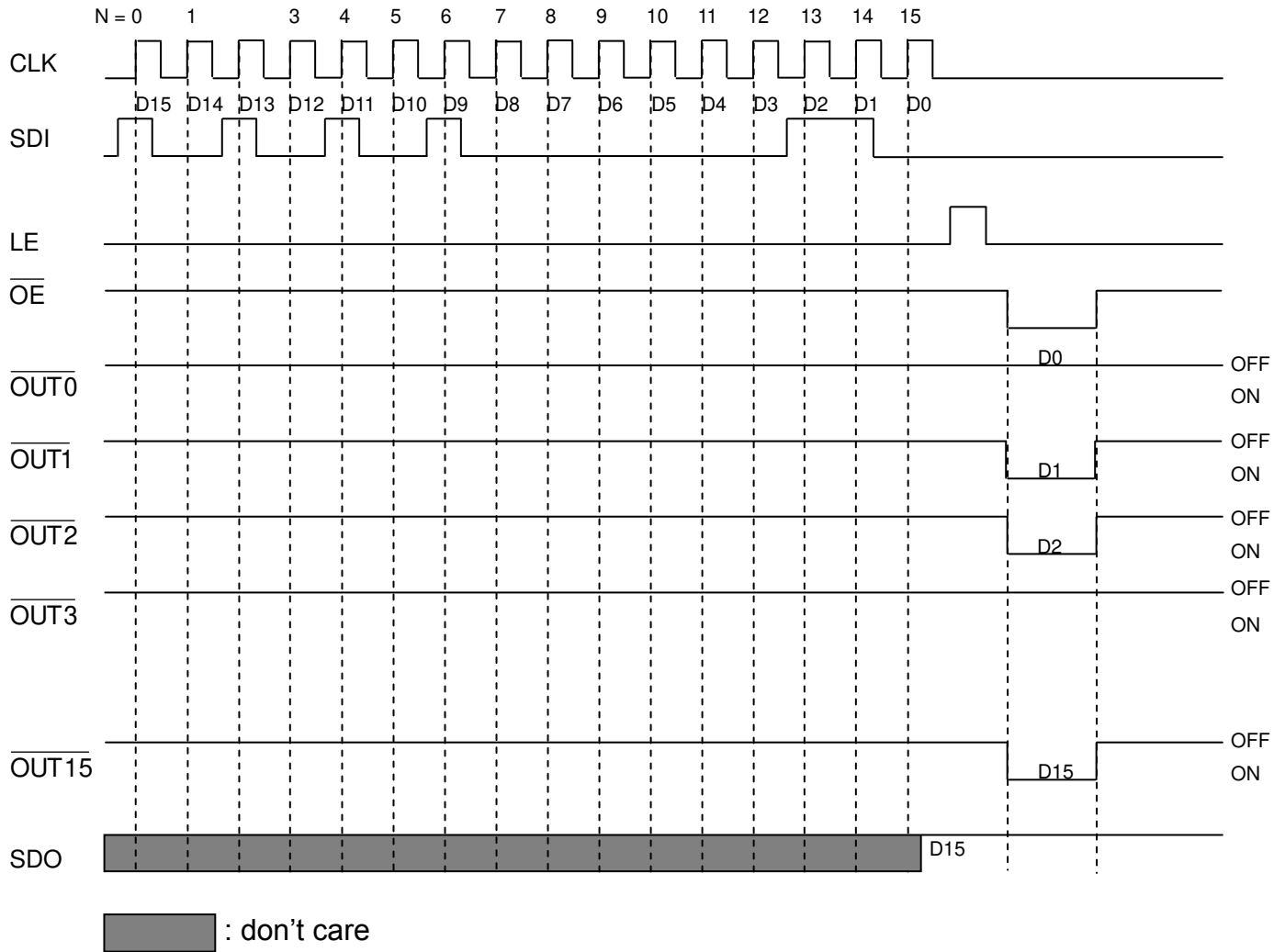

Truth Table

CLK	LE	OE	SDI	OUT0 ... OUT 7 ... OUT15	SDO
	H	L	D _n	$\overline{D_n} \dots \overline{D_{n-7}} \dots \overline{D_{n-15}}$	D _{n-15}
	L	L	D _{n+1}	No Change	D _{n-14}
	H	L	D _{n+2}	$\overline{D_{n+2}} \dots \overline{D_{n-5}} \dots \overline{D_{n-13}}$	D _{n-13}
	X	L	D _{n+3}	$\overline{D_{n+2}} \dots \overline{D_{n-5}} \dots \overline{D_{n-13}}$	D _{n-13}
	X	H	D _{n+4}	Off	D _{n-13}

Maximum Ratings

Characteristic		Symbol	Rating	Unit
Supply Voltage		V_{DD}	0~7.0	V
Input Voltage(SDI, CLK, LE, GCLK)		V_{IN}	-0.4~ $V_{DD}+0.4$	V
Output Current		I_{OUT}	+30	mA
Sustaining Voltage at OUT Port		V_{DS}	$V_{DD}+0.3$	V
GND Terminal Current		I_{GND}	480	mA
Power Dissipation (On PCB, $T_a=25^{\circ}C$)*	GF-type	P_D	2.34	W
	GP-type		1.76	
	GM-type		1.33	
	GFN-type		3.12	
Thermal Resistance (On PCB, $T_a=25^{\circ}C$)*	GF-type	$R_{th(j-a)}$	53.28	$^{\circ}C/W$
	GP-type		70.90	
	GM-type		93.5	
	GFN-type		40.01	
Junction Temperature		$T_{j,max}$	150**	$^{\circ}C$
Operating Ambient Temperature		T_{opr}	-40~+85	$^{\circ}C$
Storage Temperature		T_{stg}	-55~+150	$^{\circ}C$
ESD Rating	HBM(MIL-STD-883G Method 3015.7)	HBM	Class 3A (5000V)	
	MM(JEDEC EIA/JESD22-A115)	MM	Class M4 ($\geq 400V$)	

*The PCB size is 76.2mm*114.3mm in simulation. Please refer to JEDEC JESD51.

** Operation at the maximum rating for extended periods may reduce the device reliability; therefore, the suggested junction temperature of the device is under 125 $^{\circ}C$.

Note: The performance of thermal dissipation is strongly related to the size of thermal pad, thickness and layer numbers of the PCB. The empirical thermal resistance may be different from simulative value. Users should plan for expected thermal dissipation performance by selecting package and arranging layout of the PCB to maximize the capability.

Electrical Characteristics (V_{DD}= 5.0V, Ta=25°C)

Characteristics		Symbol	Condition	Min.	Typ.	Max.	Unit	
Supply Voltage		V _{DD}	-	4.5	5.0	5.5	V	
Sustaining Voltage at OUT Ports		V _{DS}	$\overline{\text{OUT0}} \sim \overline{\text{OUT15}}$	V _{DD} +0.3	-	-	V	
Output Current		I _{OUT}	Refer to “Test Circuit for Electrical Characteristics”	1.0	-	25	mA	
		I _{OH}	SDO	-	-1.0	-	mA	
		I _{OL}	SDO	-	1.0	-	mA	
Input Voltage	“H” level	V _{IH}	T _a =-40~85°C	0.7 x V _{DD}	-	V _{DD}	V	
	“L” level	V _{IL}	T _a =-40~85°C	GND	-	0.3 x V _{DD}	V	
Output Leakage Current		I _{OH}	V _{DD} +0.3V	100	-	-	nA	
Output Voltage	SDO	V _{OL}	I _{OL} =+1.0mA	-	-	0.4	V	
		V _{OH}	I _{OH} =-1.0mA	4.6	-	-	V	
Current Skew (Channel)		dI _{OUT1}	I _{OUT} =10.05mA V _{DS} =1.0V	R _{ext} =1820Ω	-	±1.5	±2.5	%
Current Skew (IC)		dI _{OUT2}	I _{OUT} =10.05mA V _{DS} =1.0V	R _{ext} =1820Ω	-	±1.5	±3.0	%
Output Current vs. Output Voltage Regulation		%/dV _{DS}	V _{DS} within 1.0V and 3.0V	-	±0.1	±0.3	%/V	
Output Current vs. Supply Voltage Regulation		%/dV _{DD}	V _{DD} within 4.5V and 5.5V	-	±0.5	±1.0	%/V	
Pull-up Resistor		R _{IN(up)}	$\overline{\text{OE}}$	125	350	600	KΩ	
Pull-down Resistor		R _{IN(down)}	LE	125	350	600	KΩ	
Supply Current	“OFF”	I _{DD(off) 1}	R _{ext} =Open, $\overline{\text{OUT0}} \sim \overline{\text{OUT15}} = \text{Off}$	-	3.0	-	mA	
		I _{DD(off) 2}	R _{ext} =1820Ω, (10.7mA) $\overline{\text{OUT0}} \sim \overline{\text{OUT15}} = \text{Off}$	-	6.80	-		
		I _{DD(off) 3}	R _{ext} =1050Ω, (18.8mA) $\overline{\text{OUT0}} \sim \overline{\text{OUT15}} = \text{Off}$	-	10.09	-		
	“ON”	I _{DD(on) 1}	R _{ext} =1820Ω, (10.7mA) $\overline{\text{OUT0}} \sim \overline{\text{OUT15}} = \text{On}$	-	6.92	-		
		I _{DD(on) 2}	R _{ext} =1050Ω, (18.8mA) $\overline{\text{OUT0}} \sim \overline{\text{OUT15}} = \text{On}$	-	10.31	-		

Electrical Characteristics (V_{DD}= 3.3V, Ta=25°C)

Characteristics		Symbol	Condition	Min.	Typ.	Max.	Unit
Supply Voltage		V _{DD}	-	3.0	3.3	3.6	V
Sustaining Voltage at OUT Ports		V _{DS}	$\overline{\text{OUT0}} \sim \overline{\text{OUT15}}$	V _{DD} +0.3	-	-	V
Output Current		I _{OUT}	Refer to "Test Circuit for Electrical Characteristics"	1	-	10	mA
		I _{OH}	SDO, V _{OH} =2.9V	-	-1.0	-	mA
		I _{OL}	SDO, V _{OL} =0.4V	-	1.0	-	mA
Input Voltage	"H" level	V _{IH}	T _a =-40~85°C	0.7 x V _{DD}	-	V _{DD}	V
	"L" level	V _{IL}	T _a =-40~85°C	GND	-	0.3 x V _{DD}	V
Output Leakage Current		I _{OH}	V _{DD} +0.3V	100	-	-	nA
Output Voltage	SDO	V _{OL}	I _{OL} =+1.0mA	-	-	0.4	V
		V _{OH}	I _{OH} =-1.0mA	2.9	-	-	V
Current Skew		dI _{OUT1}	I _{OUT} =25.8mA V _{DS} =1.0V R _{ext} =720Ω	-	±1.5	±2.5	%
Current Skew		dI _{OUT2}	I _{OUT} =25.8mA V _{DS} =1.0V R _{ext} =720Ω	-	±1.5	±3.0	%
Output Current vs. Output Voltage Regulation		%/dV _{DS}	V _{DS} within 1.0V and 3.0V	-	±0.1	±0.3	%/V
Output Current vs. Supply Voltage Regulation		%/dV _{DD}	V _{DD} within 3.0V and 4.5V	-	±0.5	±1.0	%/V
Pull-up Resistor		R _{IN(up)}	$\overline{\text{OE}}$	125	350	600	KΩ
Pull-down Resistor		R _{IN(down)}	LE	125	350	600	KΩ
Supply Current	"OFF"	I _{DD(off) 1}	R _{ext} = Open, $\overline{\text{OUT0}} \sim \overline{\text{OUT15}}$ =Off	-	2.45	-	mA
		I _{DD(off) 2}	R _{ext} =1820Ω, (10.05mA) $\overline{\text{OUT0}} \sim \overline{\text{OUT15}}$ =Off	-	6.42	-	
		I _{DD(off) 3}	R _{ext} =16KΩ, (1.14mA) $\overline{\text{OUT0}} \sim \overline{\text{OUT15}}$ =Off	-	2.53	-	
	"ON"	I _{DD(on) 1}	R _{ext} =1820Ω, (10.05mA) $\overline{\text{OUT0}} \sim \overline{\text{OUT15}}$ =On	-	6.52	-	
		I _{DD(on) 2}	R _{ext} =16KΩ, (1.14mA) $\overline{\text{OUT0}} \sim \overline{\text{OUT15}}$ =Off	-	2.55	-	

Test Circuit for Electrical Characteristics

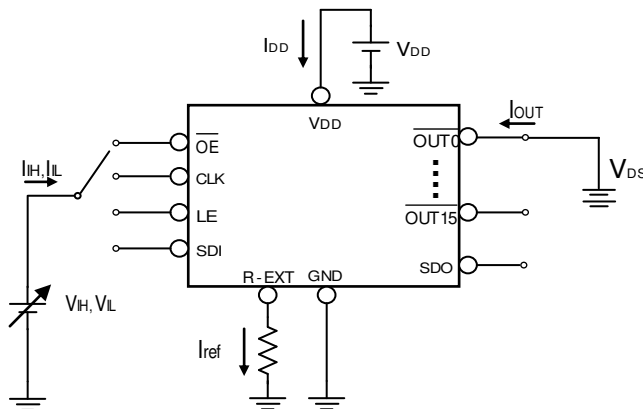

Switching Characteristics (V_{DD}= 5.0V , Ta=25 °C)

Characteristics		Symbol	Condition	Min.	Typ.	Max.	Unit
Propagation Delay Time ("L" to "H")	LE- $\overline{\text{OUT0}}$	t _{pLH2}	V _{DD} =5.0V V _{DS} =1.0V V _{IH} =V _{DD} V _{IL} =GND R _{ext} =1820Ω V _L =4.0V R _L =300Ω C _L =10pF	23	29	35	ns
	$\overline{\text{OE}}$ - $\overline{\text{OUT0}}$	t _{pLH3}		19	24	29	ns
	CLK-SDO	t _{pLH}		23	29	35	ns
Propagation Delay Time ("H" to "L")	LE- $\overline{\text{OUT0}}$	t _{pHL2}		15	19	23	ns
	$\overline{\text{OE}}$ - $\overline{\text{OUT0}}$	t _{pHL3}		19	25	31	ns
	CLK-SDO	t _{pHL}		22	28	34	ns
Staggered Delay of Output	$\overline{\text{OUTn}}$ - $\overline{\text{OUTn+1}}$	t _{stag}		-	2	-	ns
Pulse Width	CLK	t _{w(CLK)}		20	-	-	ns
	LE	t _{w(L)}		20	-	-	ns
	$\overline{\text{OE}}$ *	t _{w(OE)}		45	55	65	ns
Hold Time for LE		t _{h(L)}		5	-	-	ns
Setup Time for LE		t _{su(L)}		5	-	-	ns
Hold Time for SDI		t _{h(D)}		5	-	-	ns
Setup Time for SDI		t _{su(D)}	3	-	-	ns	
SDO Rise Time		t _{r,SDO}	3	10	15	ns	
SDO Fall Time		t _{f,SDO}	3	10	15	ns	
Output Rise Time of Output Ports		t _{or}	25	30	39	ns	
Output Fall Time of Output Ports		t _{of}	25	30	39	ns	

Switching Characteristics ($V_{DD}=3.3V$, $T_a=25^\circ C$)

Characteristics		Symbol	Condition	Min.	Typ.	Max.	Unit
Propagation Delay Time ("L" to "H")	LE- $\overline{OUT0}$	t_{pLH2}	$V_{DD}=3.3V$ $V_{DS}=1.0V$ $V_{IH}=V_{DD}$ $V_{IL}=GND$ $R_{ext}=1820\Omega$ $V_L=4.0V$ $R_L=300\Omega$ $C_L=10pF$	23	29	35	ns
	\overline{OE} - $\overline{OUT0}$	t_{pLH3}		29	37	45	ns
	CLK-SDO	t_{pLH}		34	42	50	ns
Propagation Delay Time ("H" to "L")	LE- $\overline{OUT0}$	t_{pHL2}		14	18	22	ns
	\overline{OE} - $\overline{OUT0}$	t_{pHL3}		22	28	34	ns
	CLK-SDO	t_{pHL}		32	40	48	ns
Staggered Delay of Output	\overline{OUTn} - $\overline{OUTn+1}$	t_{stag}		-	2	-	ns
Pulse Width	CLK	$t_w(CLK)$		20	-	-	ns
	LE	$t_w(L)$		20	-	-	ns
	\overline{OE}^*	$t_w(OE)$		50	60	70	ns
Hold Time for LE		$t_h(L)$		5	-	-	ns
Setup Time for LE		$t_{su}(L)$		5	-	-	ns
Hold Time for SDI		$t_h(D)$		5	-	-	ns
Setup Time for SDI		$t_{su}(D)$		3	-	-	ns
SDO Rise Time		$t_{r,SDO}$	3	10	15	ns	
SDO Fall Time		$t_{f,SDO}$	3	10	15	ns	
Output Rise Time of Output Ports		t_{or}	25	30	40	ns	
Output Fall Time of Output Ports		t_{of}	25	30	40	ns	

Test Circuit for Switching Characteristics

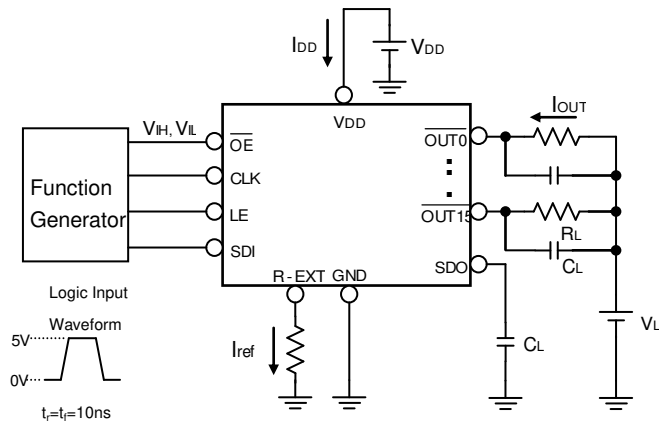

Timing Waveform

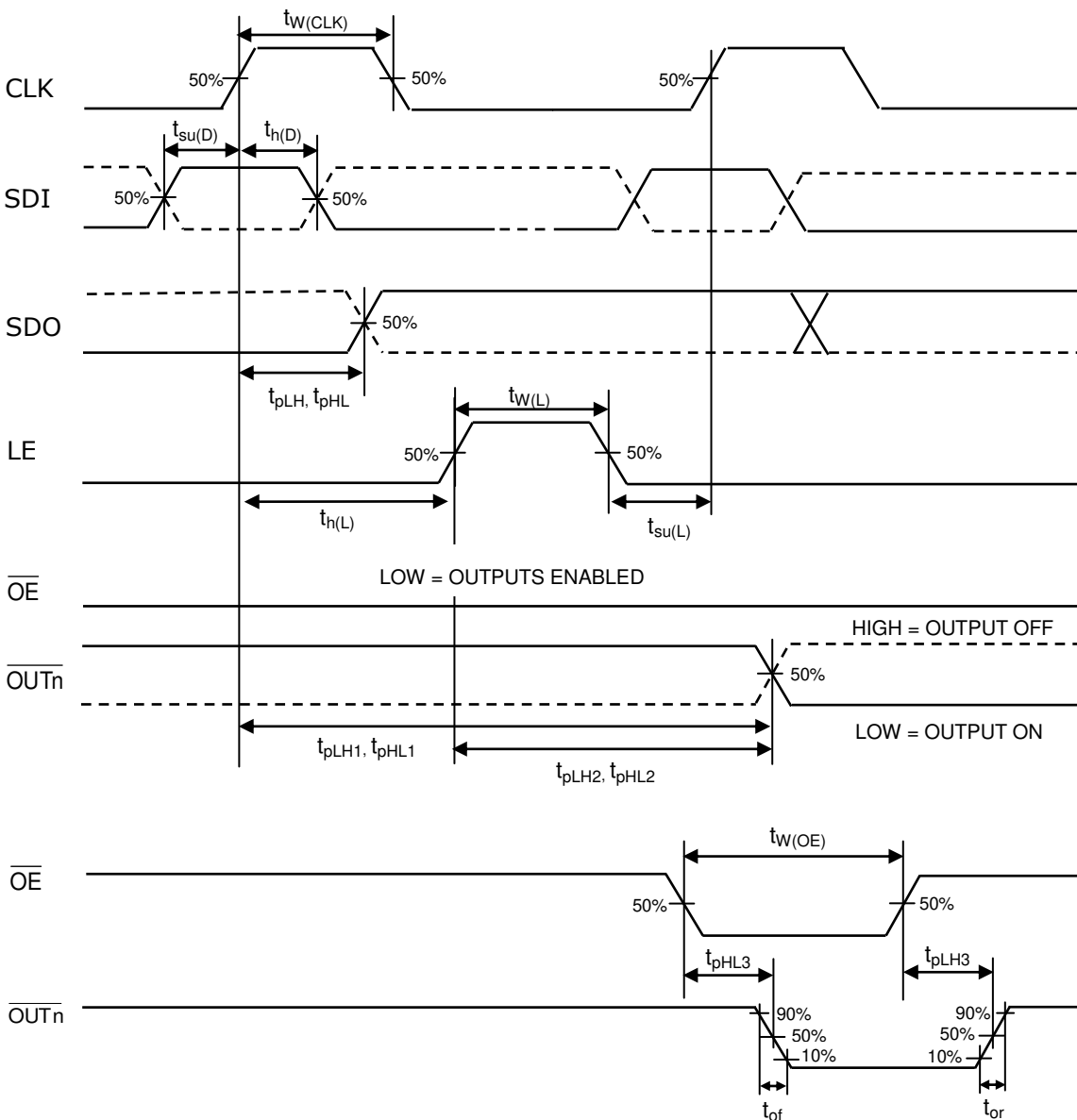

Control Command

Command Name	Signals Combination		Description
	LE	Number of CLK Rising Edge when LE is asserted	
Latch data	High	0	Latch the serial data to the output latch. Latch the serial data to the driver's internal latch.
	High	1	Latch the serial data/Buffer data to the output latch.
Write configuration	High	4	Serial data are transferred to the "configuration register"
Read configuration	High	5	"Configuration register" is shifted out to SDO.
No Action	High	2,3, >5	No action. Please do not use it.

Definition of Configuration Register

MSB														LSB	
F	E	D	C	B	A	9	8	7	6	5	4	3	2	1	0

According the driven LED, please set the configuration register by the following settings:

Red LED (R)

0	1	1	1	1	1	0	1	0	1	1	0	1	0	1	1
---	---	---	---	---	---	---	---	---	---	---	---	---	---	---	---

Green LED (G)

1	1	1	1	0	0	0	1	0	1	1	0	1	0	1	1
---	---	---	---	---	---	---	---	---	---	---	---	---	---	---	---

Blue LED (B)

1	1	1	0	1	1	0	1	0	1	1	0	1	0	1	1
---	---	---	---	---	---	---	---	---	---	---	---	---	---	---	---

Pre-charge waveform

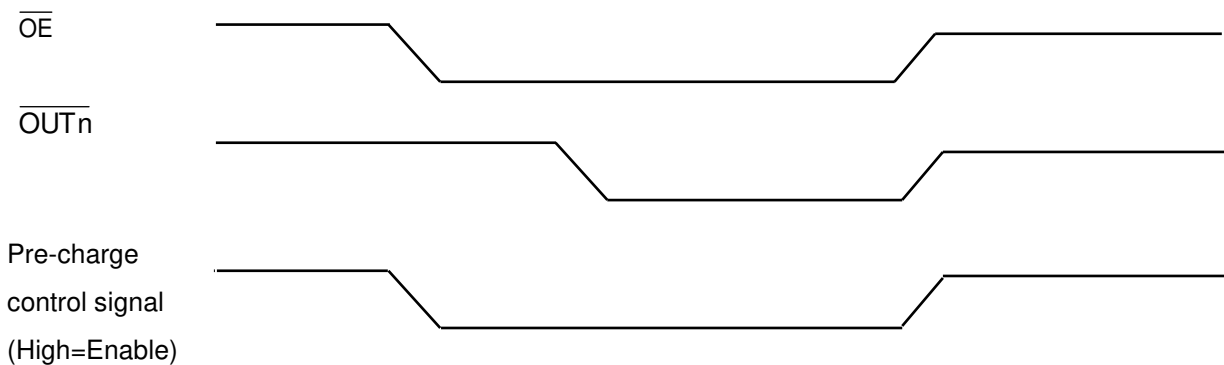

Application Information

Constant Current

To design LED displays, MBI5124 provides nearly no variations in current from channel to channel and from IC to IC.

This can be achieved by:

- 1) The maximum current variation between channels is less than $\pm 2.5\%$, and that between ICs is less than $\pm 3\%$.
- 2) In addition, the current characteristic of output stage is flat and users can refer to the figure as shown below. The output current can be kept constant regardless of the variations of LED forward voltages (V_F). This performs as a perfection of load regulation.

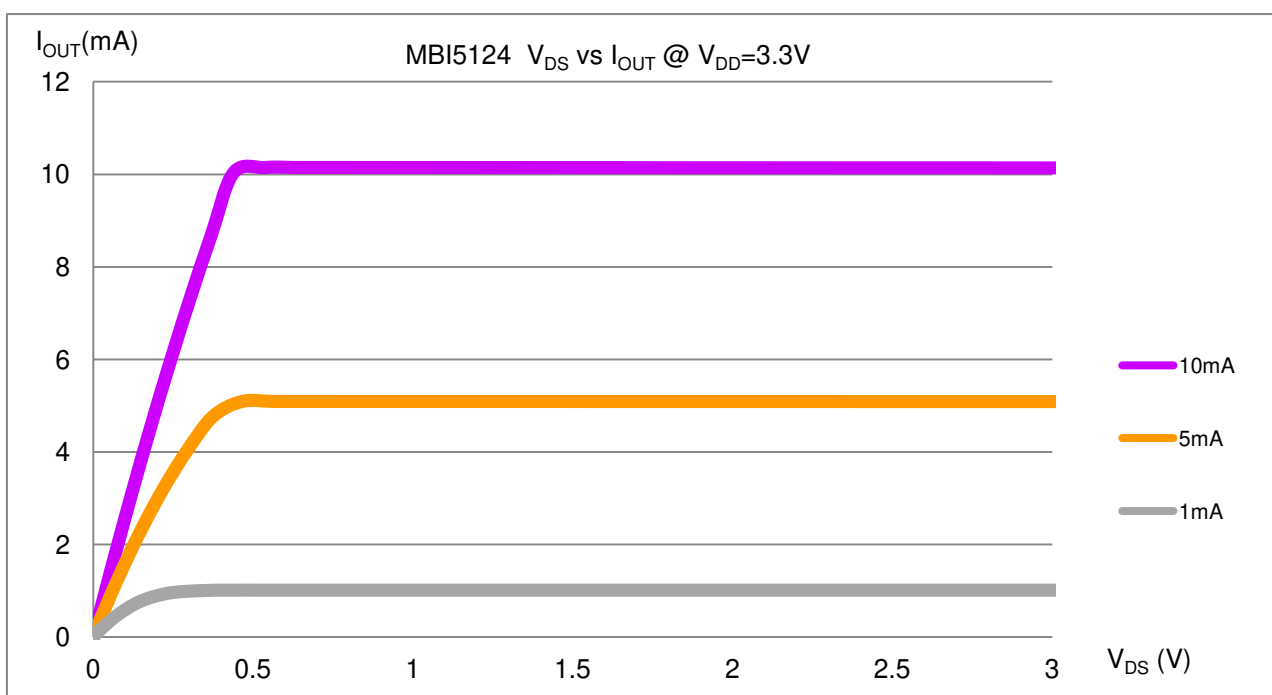
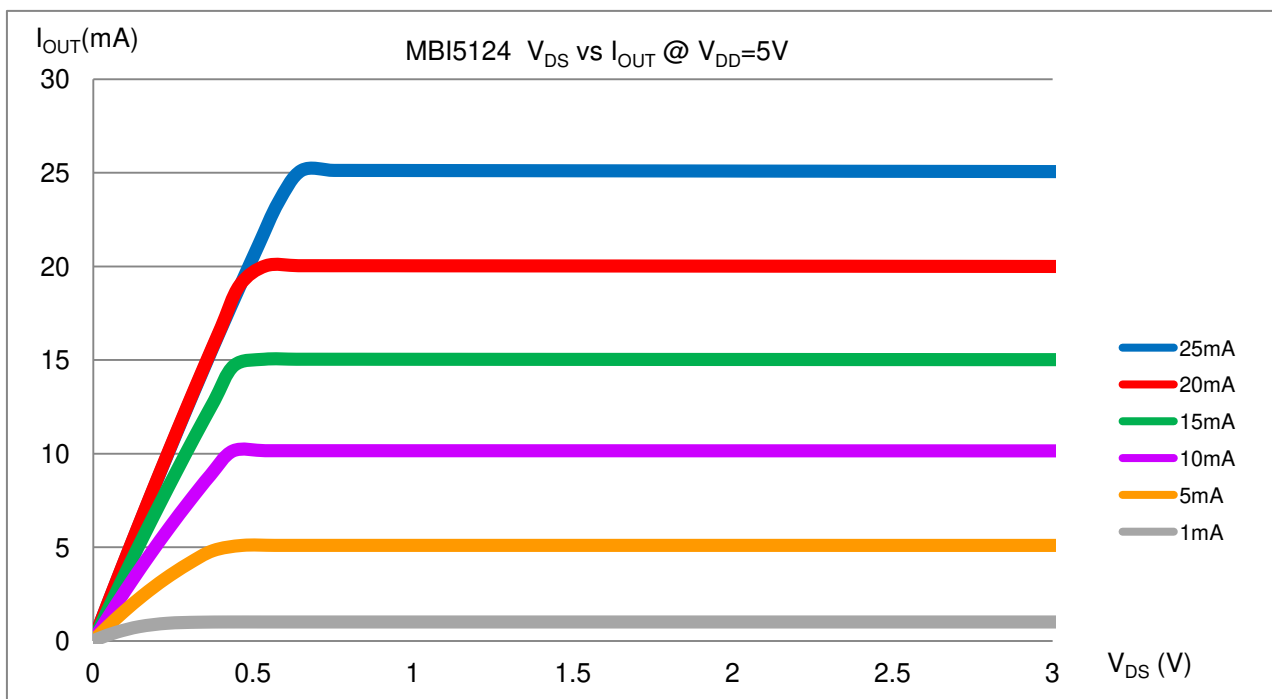

Adjusting Output Current

The output current of each channel (I_{OUT}) is set by an external resistor, R_{ext} . The relationship between I_{OUT} and R_{ext} is shown in the following figure.

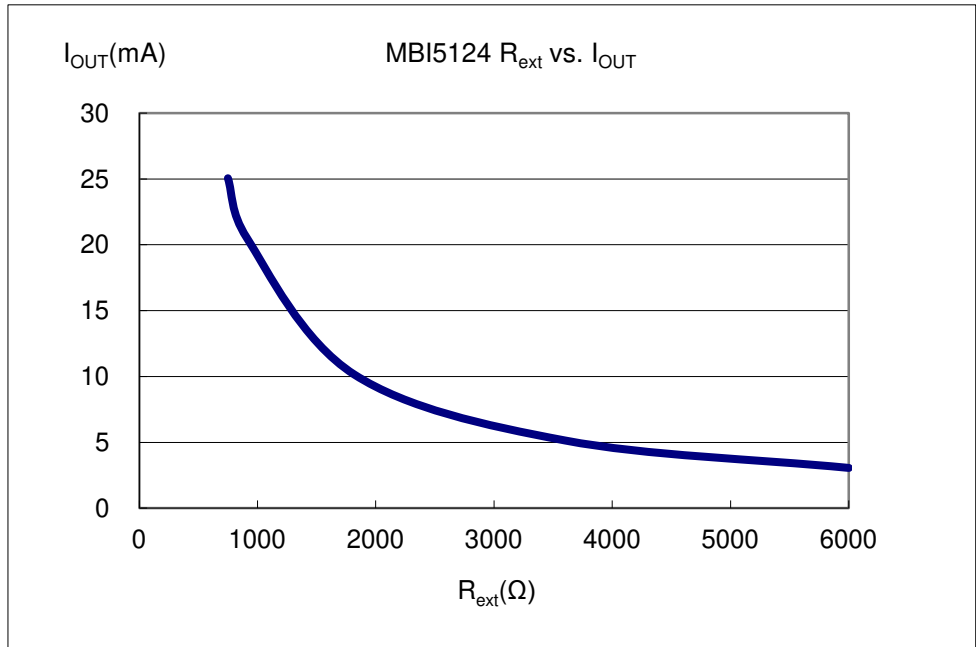

Also, the output current can be calculated from the equation:

$$V_{R-EXT}=1.23V: I_{OUT}=V_{R-EXT} \cdot (1/R_{ext}) \times 15; R_{ext}=(V_{R-EXT}/I_{OUT}) \times 15$$

Where R_{ext} is the resistance of the external resistor connected to R-EXT terminal and V_{R-EXT} is the voltage of R-EXT terminal. The magnitude of current (as a function of R_{ext}) is around 20mA at 930 Ω and 10mA at 1860 Ω .

Output Staggered Delay

MBI5124 has a built-in staggered circuit to perform delay mechanism. The 16 output channels are categorized into 2 groups $\overline{OUT2n}$ and $\overline{OUT2n+1}$, and each group outputs current by the staggered sequence, 2ns.

Soldering Process of “Pb-free & Green” Package Plating*

Macroblock has defined "Pb-Free & Green" to mean semiconductor products that are compatible with the current RoHS requirements and selected 100% pure tin (Sn) to provide forward and backward compatibility with the higher-temperature Pb-free processes. Pure tin is widely accepted by customers and suppliers of electronic devices in Europe, Asia and the US as the lead-free surface finish of choice to replace tin-lead. Also, it adopts tin/lead (SnPb) solder paste, and please refer to the JEDEC J-STD-020C for the temperature of solder bath. However, in the whole Pb-free soldering processes and materials, 100% pure tin (Sn) will all require from 245 °C to 260 °C for proper soldering on boards, referring to JEDEC J-STD-020C as shown below.

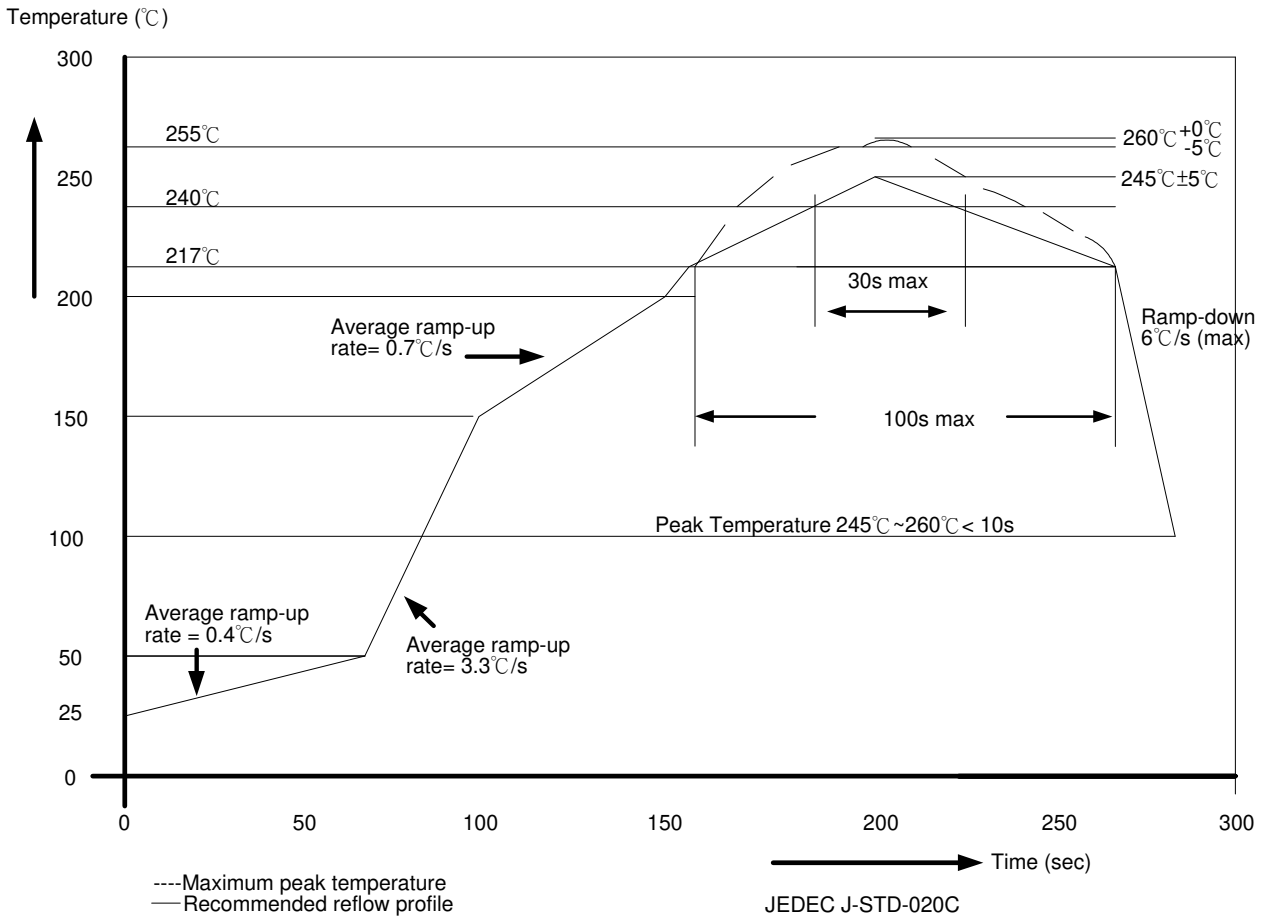

Package Thickness	Volume mm ³ <350	Volume mm ³ 350-2000	Volume mm ³ ≥2000
<1.6mm	260 +0 °C	260 +0 °C	260 +0 °C
1.6mm – 2.5mm	260 +0 °C	250 +0 °C	245 +0 °C
≥2.5mm	250 +0 °C	245 +0 °C	245 +0 °C

*For details, please refer to Macroblock’s “Policy on Pb-free & Green Package”.

Package Power Dissipation (P_D)

The maximum allowable package power dissipation is determined as $P_{D(max)} = (T_j - T_a) / R_{th(j-a)}$. When 16 output channels are turned on simultaneously, the actual package power dissipation is

$P_{D(act)} = (I_{DD} \times V_{DD}) + (I_{OUT} \times Duty \times V_{DS} \times 16)$. Therefore, to keep $P_{D(act)} \leq P_{D(max)}$, the allowable maximum output current as a function of duty cycle is:

$I_{OUT} = \{[(T_j - T_a) / R_{th(j-a)}] - (I_{DD} \times V_{DD})\} / V_{DS} / Duty / 16$, where $T_j = 150^\circ\text{C}$.

Package	R _{th(j-a)} (°C/W)	P _D (W)
GF	53.28	2.34
GP	70.90	1.76
GM	93.50	1.33

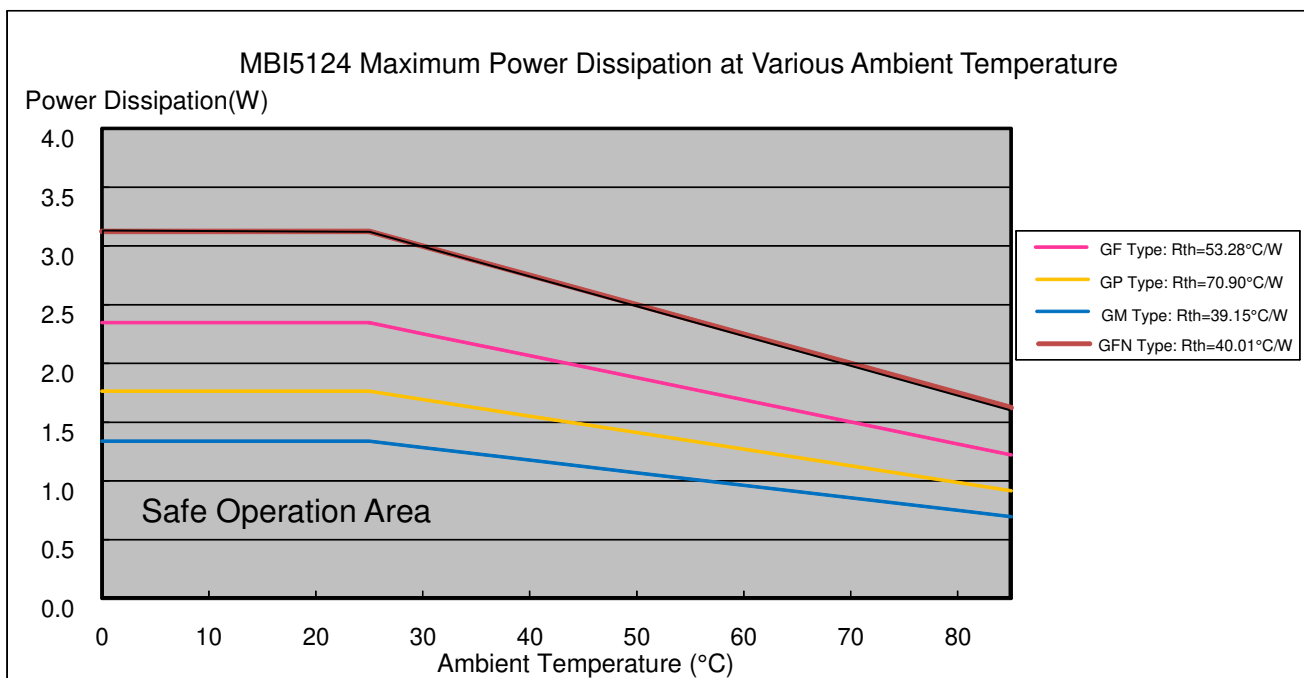

Load Supply Voltage (V_{LED})

with Ghosting Elimination

MBI5124 are designed to operate with V_{DS} ranging from 0.4V to 0.8V (depending on $I_{OUT}=1\sim 25mA$) considering the package power dissipating limits. V_{DS} may be higher enough to make $P_{D(act)} > P_{D(max)}$ when $V_{LED}=5V$ and $V_{DS}=V_{LED}-V_F$, in which V_{LED} is the load supply voltage. In this case, it is recommended to use the lowest possible supply voltage or to set an external voltage reducer, V_{DROP} .

A voltage reducer lets $V_{DS}=(V_{LED}-V_F)-V_{DROP}$.

Resistors or Zener diode can be used in the applications as shown in the following figures.

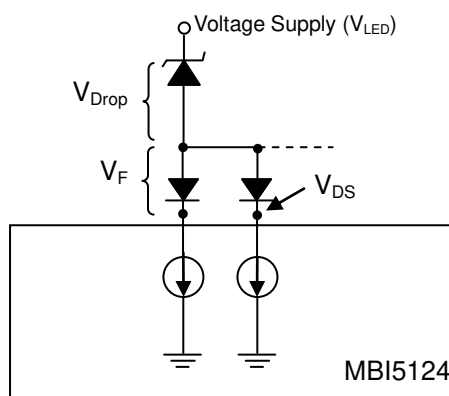
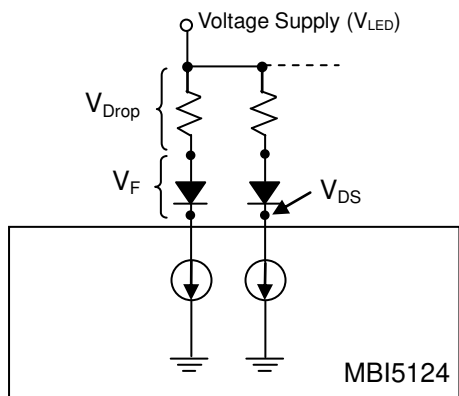

Package Outline

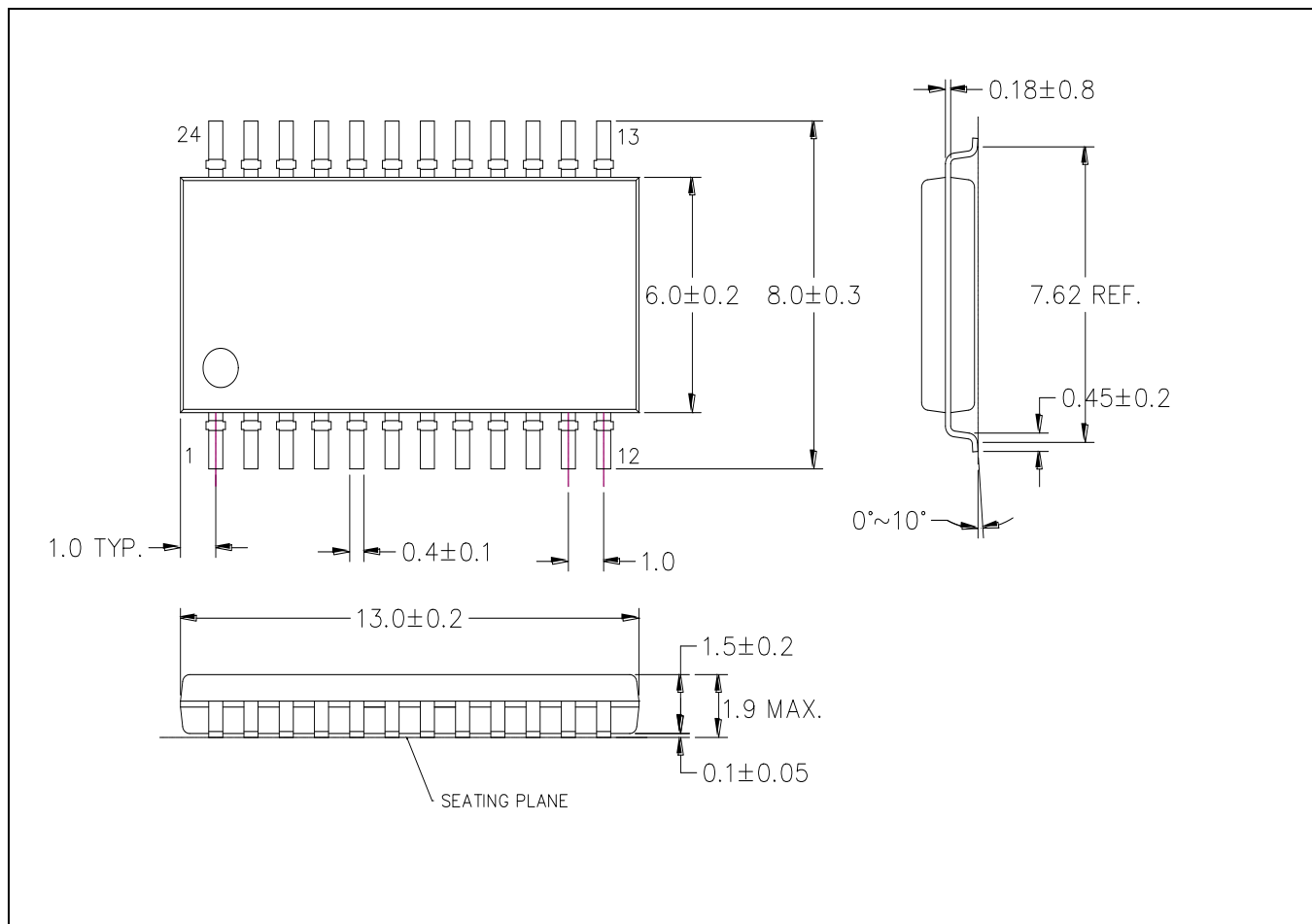

MBI5124GF Outline Drawing

Note: The unit for the outline drawing is mm

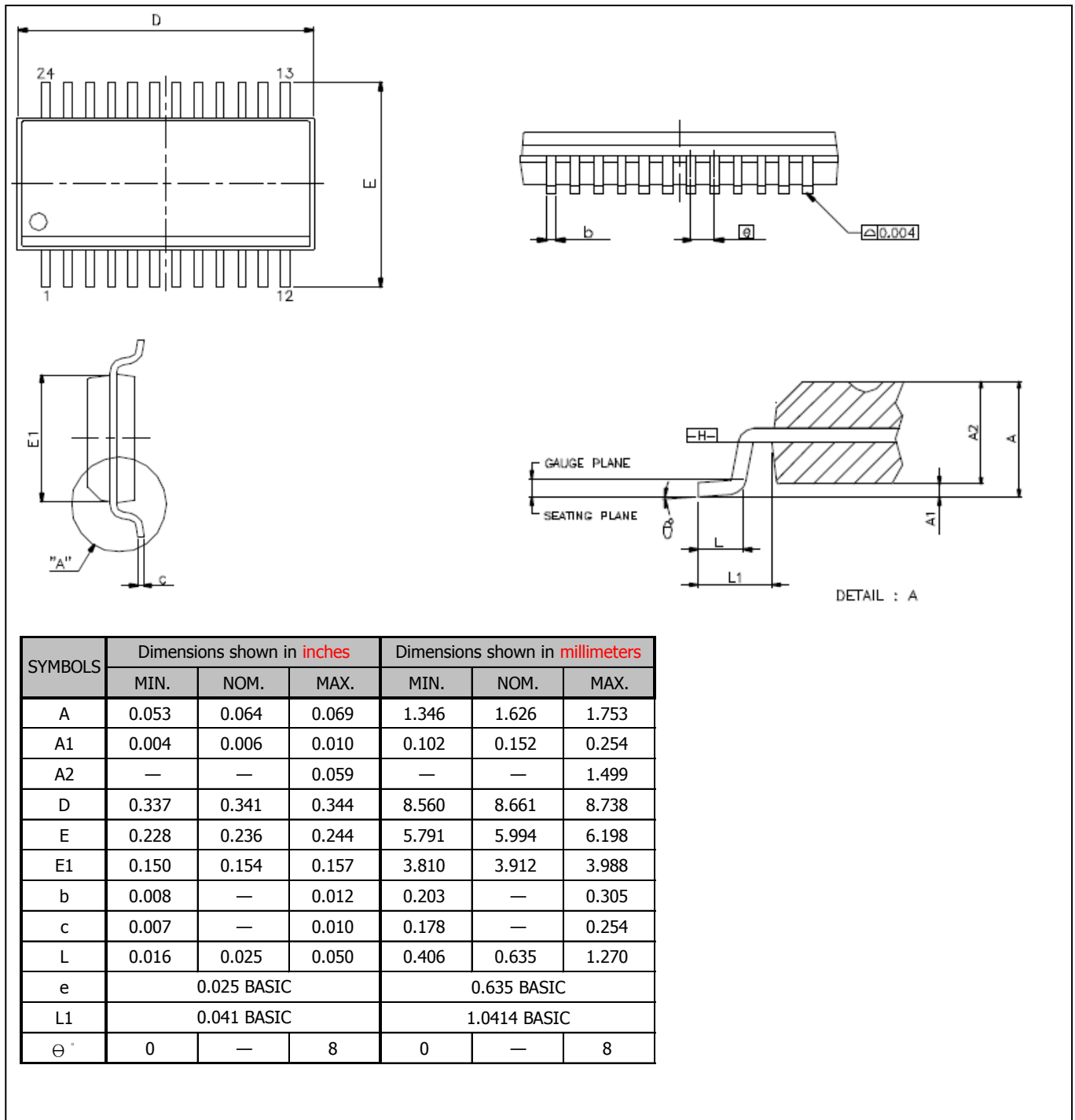

MBI5124GP Outline Drawing

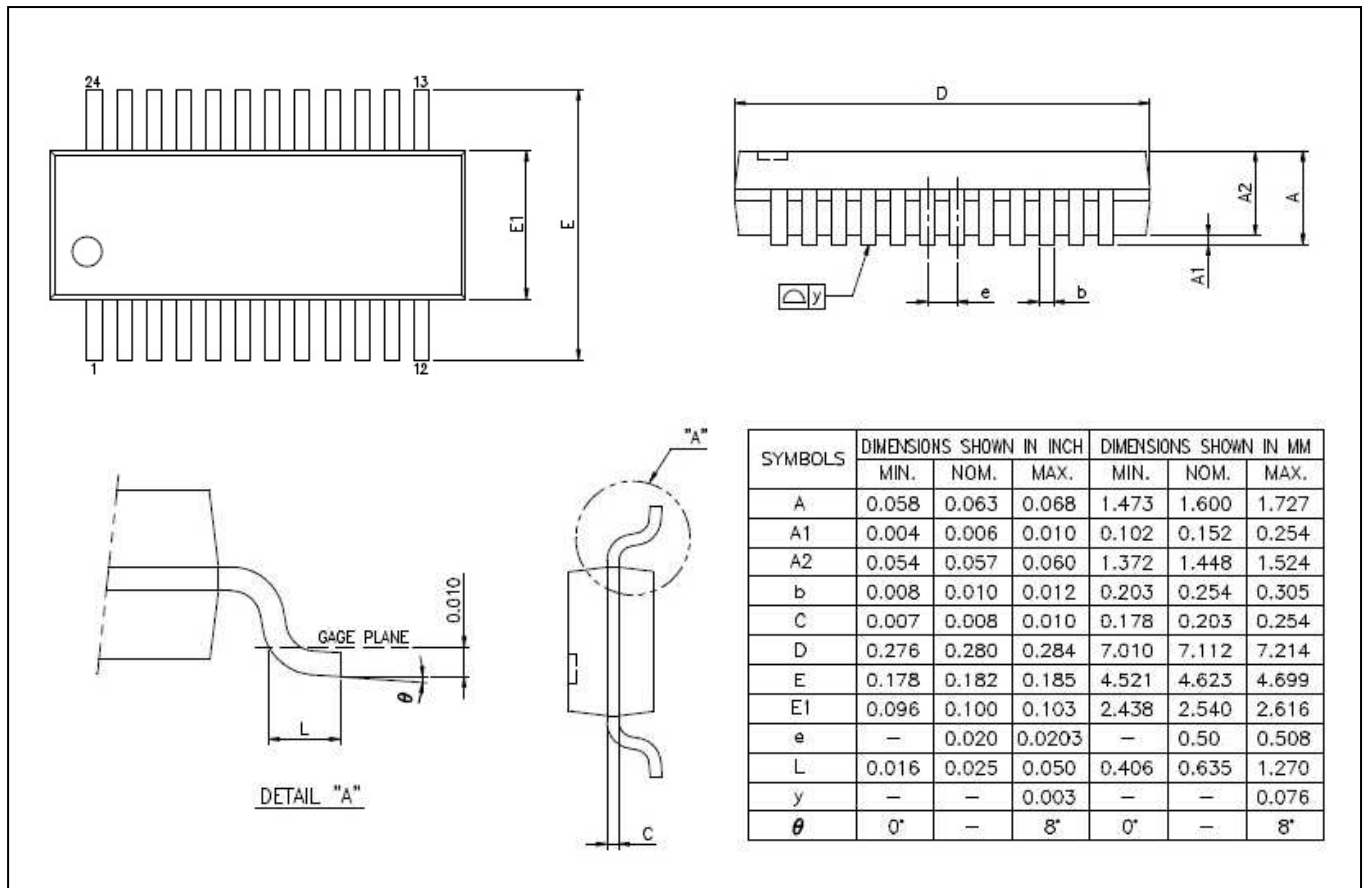

MBI5120GM Outline Drawing

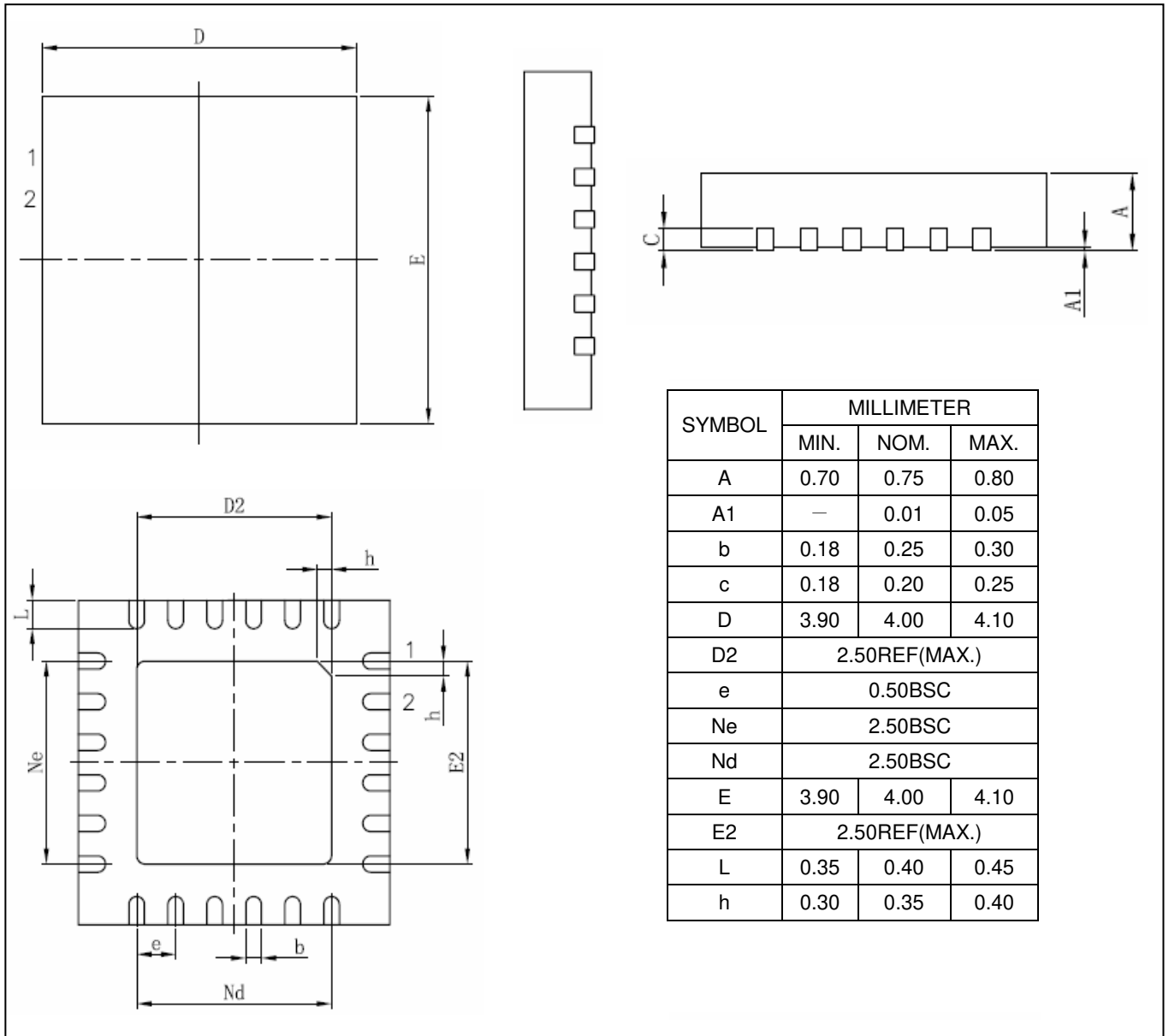

MBI5124GFN Outline Drawing

Note: The thermal pad size may exist a tolerance due to the manufacturing process, please use the maximum dimensions-D2(max. 2.50mm) x E2(max. 2.50mm) for the thermal pad layout. In addition, to avoid the short circuit risk, the vias or circuit traces shall not pass through the maximum area of thermal pad.

Product Top-mark Information

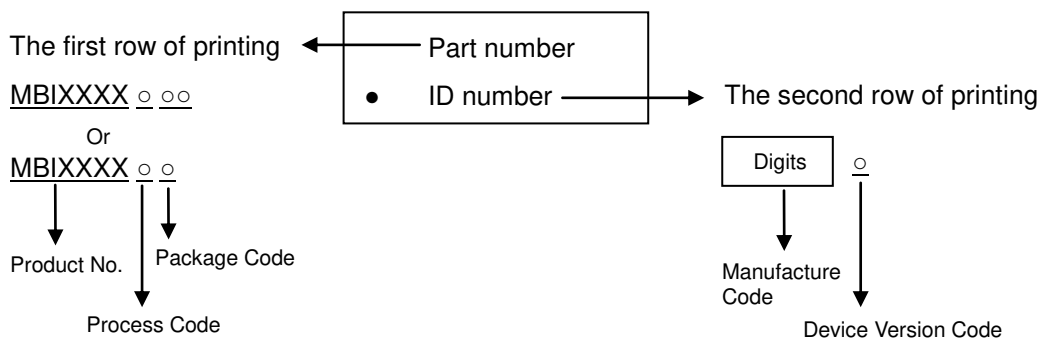

Product Revision History

Datasheet Version	Device Version Code
V1.00	A
V1.01	A
V1.02	A
V0.01	B

Product Ordering Information

Product Ordering Number*	RoHS Compliant Package Type	Weight (g)
MBI5124GF-B	SOP24L-300-1.00	0.28
MBI5124GP-B	SSOP24L-150-0.64	0.11
MBI5124GM-B	mSSOP24L-100-0.5	0.079
MBI5124GFN-B	QFN24L-4*4-0.5	0.0379

*Please place your order with the “product ordering number” information on your purchase order (PO).

Disclaimer

Macroblock reserves the right to make changes, corrections, modifications, and improvements to their products and documents or discontinue any product or service. Customers are advised to consult their sales representative for the latest product information before ordering. All products are sold subject to the terms and conditions supplied at the time of order acknowledgement, including those pertaining to warranty, patent infringement, and limitation of liability.

Macroblock's products are not designed to be used as components in device intended to support or sustain life or in military applications. Use of Macroblock's products in components intended for surgical implant into the body, or other applications in which failure of Macroblock's products could create a situation where personal death or injury may occur, is not authorized without the express written approval of the Managing Director of Macroblock. Macroblock will not be held liable for any damages or claims resulting from the use of its products in medical and military applications.

All text, images, logos and information contained on this document is the intellectual property of Macroblock. Unauthorized reproduction, duplication, extraction, use or disclosure of the above mentioned intellectual property will be deemed as infringement.