



**HESTORE.HU**

elektronikai alkatrész áruház

**EN:** This Datasheet is presented by the manufacturer.

Please visit our website for pricing and availability at [www.hestore.hu](http://www.hestore.hu).

# LINEAR SYSTEMS

Twenty-Five Years Of Quality Through Innovation

## PAD SERIES PICO AMPERE DIODES

FEATURES	
DIRECT REPLACEMENT FOR SILICONIX PAD SERIES	
REVERSE BREAKDOWN VOLTAGE	$BV_R \geq -30V$
REVERSE CAPACITANCE	$C_{rss} \leq 2.0pF$
ABSOLUTE MAXIMUM RATINGS <sup>1</sup>	
@ 25 °C (unless otherwise stated)	
Maximum Temperatures	
Storage Temperature	-55 to +150 °C
Operating Junction Temperature	-55 to +150 °C
Maximum Power Dissipation	
Continuous Power Dissipation (PAD)	300mW
Continuous Power Dissipation (J/SSTPAD)	350mW
Maximum Currents	
Forward Current (PAD)	50mA
Forward Current (J/SSTPAD)	10mA

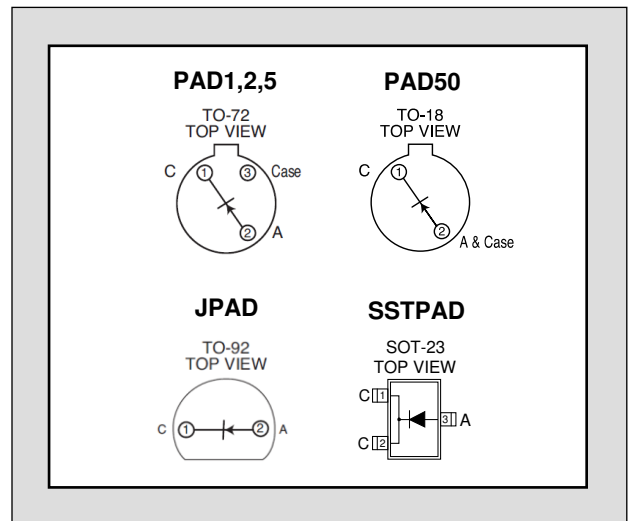

### COMMON ELECTRICAL CHARACTERISTICS @ 25 °C (unless otherwise stated)

SYMBOL	CHARACTERISTIC	MIN	TYP	MAX	UNITS	CONDITIONS	
$BV_R$	Reverse Breakdown Voltage	ALL PAD	-45		V	$I_R = -1\mu A$	
		ALL SSTPAD	-30				
		ALL JPAD	-35				
$V_F$	Forward Voltage		0.8	1.5		$I_F = 5mA$	
$C_{rss}$	Total Reverse Capacitance	PAD1,5		0.5	0.8	pF	$V_R = -5V, f = 1MHz$
		All Others		1.5	2		

### SPECIFIC ELECTRICAL CHARACTERISTICS @ 25 °C (unless otherwise stated)

SYMBOL	CHARACTERISTIC	PAD	JPAD	SSTPAD	UNITS	CONDITIONS	
$I_R$	Maximum Reverse Leakage Current	PAD1	-1			pA	$V_R = -20V$
		PAD2	-2				
		(SST/J)PAD5	-5	-5	-5		
		(SST/J)PAD10	-10	-10	-10		
		(SST/J)PAD20	-20	-20	-20		
		(SST/J)PAD50	-50	-50	-50		
		(SST/J)PAD100	-100	-100			
		(SST/J)PAD200		-200			
(SST/J)PAD500		-500					

1. Derate 2mW/°C above 25°C
2. Derate 2.8mW/°C above 25°C

**Figure 1. Operational Amplifier Protection**

Input Differential Voltage limited to 0.8V (typ) by JPADs D<sub>1</sub> and D<sub>2</sub>. Common Mode Input voltage limited by JPADs D<sub>3</sub> and D<sub>4</sub> to ±15V.

**Figure 2. Sample and Hold Circuit**

Typical Sample and Hold circuit with clipping. JPAD diodes reduce offset voltages fed capacitively from the JFET switch gate.

FIGURE 1

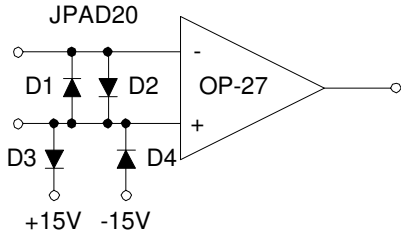
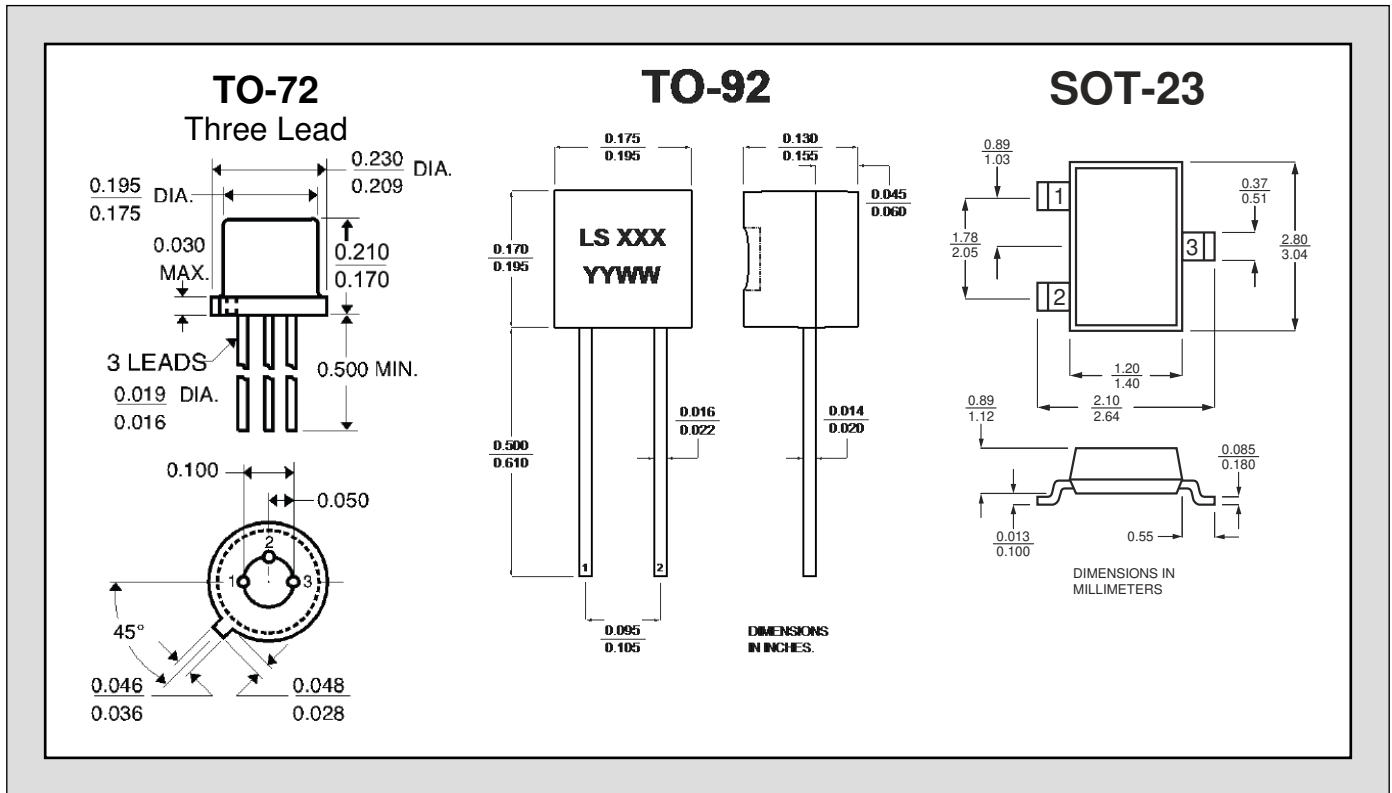
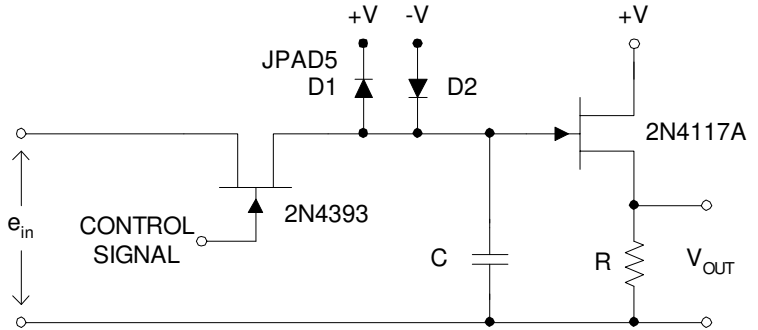

FIGURE 2



1. Absolute maximum ratings are limiting values above which serviceability may be impaired.
2. The PAD type number denotes its maximum reverse current value in pico amperes. Devices with I<sub>R</sub> values intermediate to those shown are available upon request.

Information furnished by Linear Integrated Systems is believed to be accurate and reliable. However, no responsibility is assumed for its use; nor for any infringement of patents or other rights of third parties which may result from its use. No license is granted by implication or otherwise under any patent or patent rights of Linear Integrated Systems.

Linear Integrated Systems (LIS) is a 25-year-old, third-generation precision semiconductor company providing high-quality discrete components. Expertise brought to LIS is based on processes and products developed at Amelco, Union Carbide, Intersil and Micro Power Systems by company President John H. Hall. Hall, a protégé of Silicon Valley legend Dr. Jean Hoerni, was the director of IC Development at Union Carbide, co-founder and vice president of R&D at Intersil, and founder/president of Micro Power Systems.