



**HESTORE.HU**

elektronikai alkatrész áruház

**EN:** This Datasheet is presented by the manufacturer.

Please visit our website for pricing and availability at [www.hestore.hu](http://www.hestore.hu).

## Electronic speed controller for BLDC and PMSM three phase brushless motor

### Introduction

The STEVAL-ESC001V1 reference design for electronic speed controllers (ESC) for drones fits entry-level commercial drone designs and drives any three-phase brushless (or PMSM) motor running off 6S LiPo battery packs, or any equivalent DC supply, up to 30 A peak current.

The STEVAL-ESC001V1 lets you spin a motor and its propeller in minutes thanks to STM32 Motor Control Software Development Kit (MCSDK) with ST Motor profiler (X-CUBE-MCSDK). It implements a sensorless field oriented controlled (FOC) algorithm with 3-shunt current reading, speed control and full active braking.

The reference design board can accept commands from a flight control unit through PWM signals; other communication bus interfaces like UART, CAN, and I<sup>2</sup>C are also available. The reference embeds a battery eliminator circuit working at 5 V, an NTC sensor for temperature measurement and circuitry for overcurrent/overvoltage protection (OCP/OVP). The compact form factor and current capability render this reference design suitable for electronic speed controllers on small and light unmanned aerial vehicles like professional drones.

The X-CUBE-MCSDK software package lets you refine your electronic speed controller design. They act on the FOC parameters embedded in the STM32 and experiment with the ST motor profiler to retrieve rapidly the motor parameters. The ST sensorless FOC algorithm ensures longer flight times and optimal dynamic performance.

The STEVAL-ESC001V1 is designed around the highly efficient, low  $R_{ds(on)}$  STripFET F7 power MOSFETs, the high-performance STM32F303CBT7 microcontroller with Arm<sup>®</sup> Cortex<sup>®</sup>-M4 core and the L6398 drivers.

Figure 1. STEVAL-ESC001V1 evaluation board

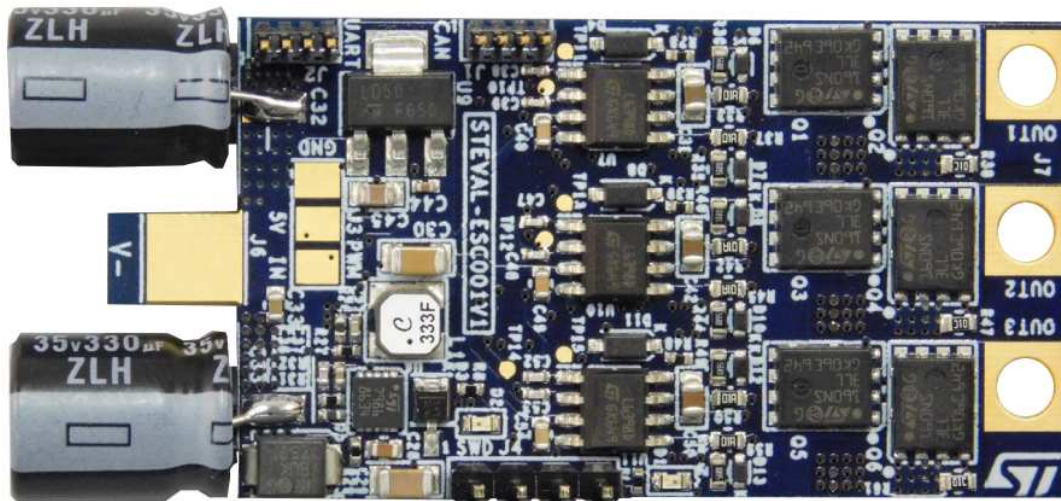

## 1 Main features

- Complete reference design for electronic speed controller implementing a sensorless FOC algorithm
- Designed for drones with 6S pack of LiPo batteries or systems with an equivalent suitable DC supply
- ESC ready for communication with any standard flight control unit (FCU): PWM or CAN
- Temperature overheating protection
- Nominal operating voltage range: 3S-6S Li-Po battery DC voltage level (11.1 to 22.2 V)
- Maximum RMS output current: 20 Arms
- Output peak current: 30 A
- Battery eliminator circuit (BEC): 5 V/0.5 A for external receiver or FCU
- Example project available on STM32 motor control software development kit ([X-CUBE-MCSDK](#))
- Supported by ST motor control software SDK and ST motor profiler
- Compact PCB design: 29.1 x 58 mm
- Further target applications:
  - motor driving for RC vehicles: electric cars, helicopter, trucks, etc.
  - any three-phase BLDC or PMSM motor application
- RoHS and WEEE compliant

### 1.1 Target application

Motor driving for remote control vehicles, UAV drones, electrical cars and boats, etc.

**Figure 2. STEVAL-ESC001V1 target applications**



## 2 Description

The STEVAL-ESC001V1 electronic speed controller (ESC) evaluation board drives a single three phase brushless motor with very high performance in sensorless mode (without position sensor).

It is designed to provide fast and efficient propulsion for remote control applications like electric cars, boats and drones and is capable of low and very high speed regulation and strong dynamic response under different load conditions.

An external signal via a communication bus between the board and a generic central unit sets the speed regulation reference and another signal reports the status of the system, including faults, which the central unit can use to trigger corrective events..

The same 6Step (or trapezoidal) control algorithm (often with no shunt resistors) drives the many different ESCs offering various motor current, size and input voltages for remote control applications.

A more sophisticated control algorithm is used in the STEVAL-ESC001V1, based on field oriented control (FOC); it features:

- better torque control
- motor current regulation in case of fast load change
- vibration reduction
- active braking function
- better efficiency
- noise reduction
- a real-time monitor of the rotor speed
- energy recovery during the deceleration

The typical system architecture pictured below shows individual ESC boards connected to single brushless motors in a quadcopter system. An external Li-Po battery powers the four boards and a wired bus carries communication between each board and an external unit such as a flight control board.

Figure 3. System structure overview

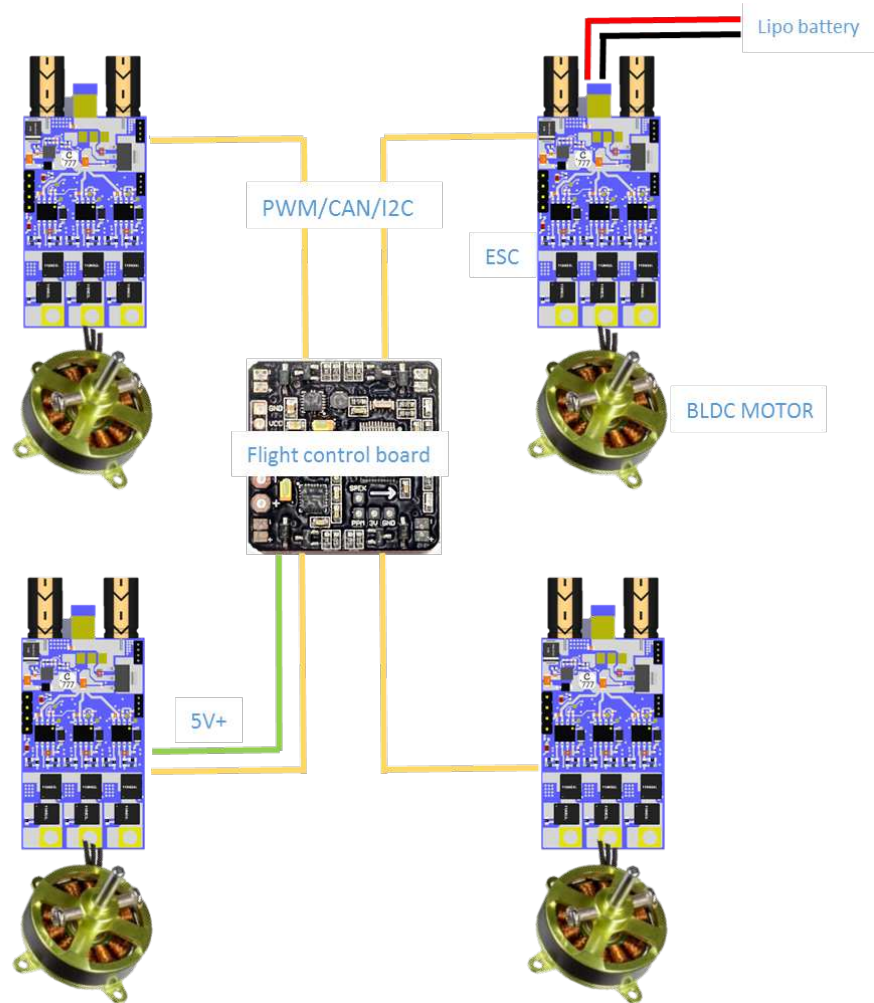
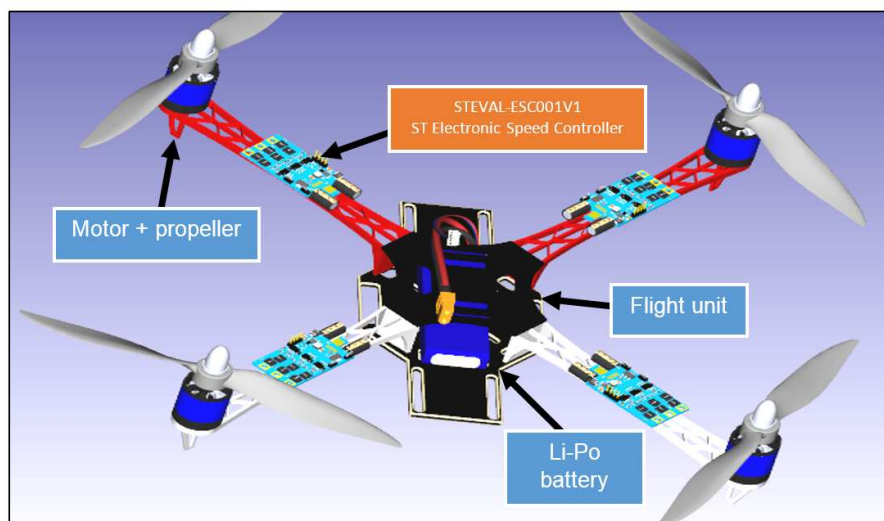

Figure 4. Typical quadcopter architecture



The on-board I<sup>2</sup>C, UART, PWM and CAN communication protocols provide maximum flexibility and a DC-DC converter with 5 V output connector (BEC) can supply an external control unit or sensor board.

## 2.1 STEVAL-ESC001V1 hardware overview

The STEVAL-ESC001V1 power and control platform is based on the ST componentry illustrated below.

**Figure 5. STEVAL-ESC001V1 block diagram**

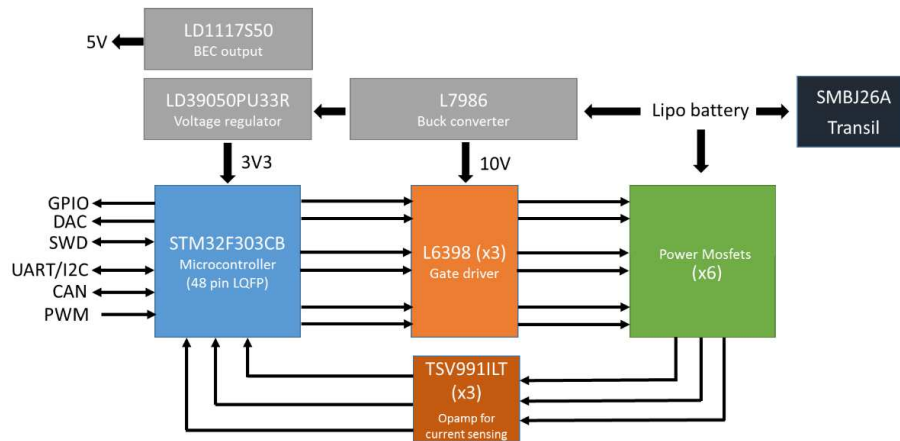

### 2.1.1 STEVAL-ESC001V1 top side components

The inverter section is formed by the L6398 gate driver and the STL160N4F7 and the Power MOSFETs.

**Figure 6. Top side features**

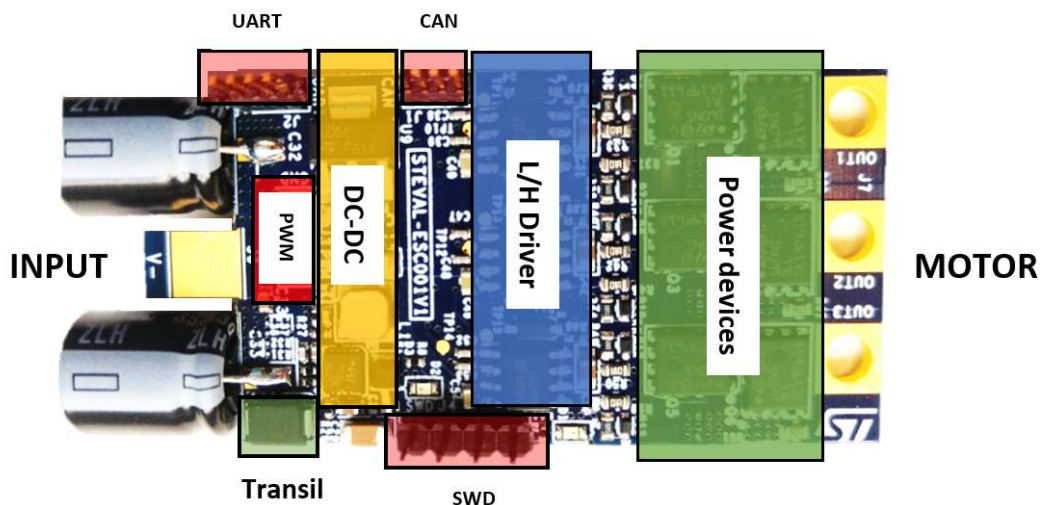

#### L6398 high voltage high and low-side driver

The L6398 is a high voltage device manufactured with the BCD™ “offline” technology. It is a single-chip half bridge gate driver for the N-channel power MOSFET or IGBT.

The high-side (floating) section is designed to stand a voltage rail up to 600 V. The logic inputs are CMOS/TTL compatible down to 3.3 V for the easy interfacing microcontroller/DSP.

Key features:

- High voltage rail up to 600 V
- dV/dt immunity  $\pm 50$  V/ns in full temperature range
- Driver current capability:
  - 290 mA source
  - 430 mA sink
- Switching times 75/35 ns rise/fall with 1 nF load



- 3.3 V, 5 V TTL/CMOS input comparators with hysteresis
- Integrated bootstrap diode
- Fixed 320 ns deadtime
- Interlocking function
- Compact and simplified layout
- Bill of material reduction
- Flexible, easy and fast design

#### **STL160N4F7 160 A STripFET™ F7 Power MOSFETs**

This N-channel Power MOSFET uses STripFET™ F7 technology with an enhanced trench gate structure that results in very low on-state resistance, while also reducing internal capacitance and gate charge for faster and more efficient switching.

#### **L7986, LD1117S50 and LD39050PU33R**

These devices provide the appropriate voltage for gate driving, BEC output and MCU power.

### **2.1.2 STEVAL-ESC001V1 bottom side components**

Bottom side componentry is mainly for the digital section; featuring an STM32F303 microcontroller for three-shunt sensorless FOC control in an LQFP 48-pin package.

#### **STM32F303xB 32-bit ARM Cortex-M4 MCU with 128 Kbytes Flash and 72 MHz CPU**

The family of microcontrollers is based on the high-performance ARM®Cortex®-M4 32-bit RISC core plus FPU operating at 72 MHz max and embedded memory protection unit (MPU).

**Figure 7. Bottom side features**

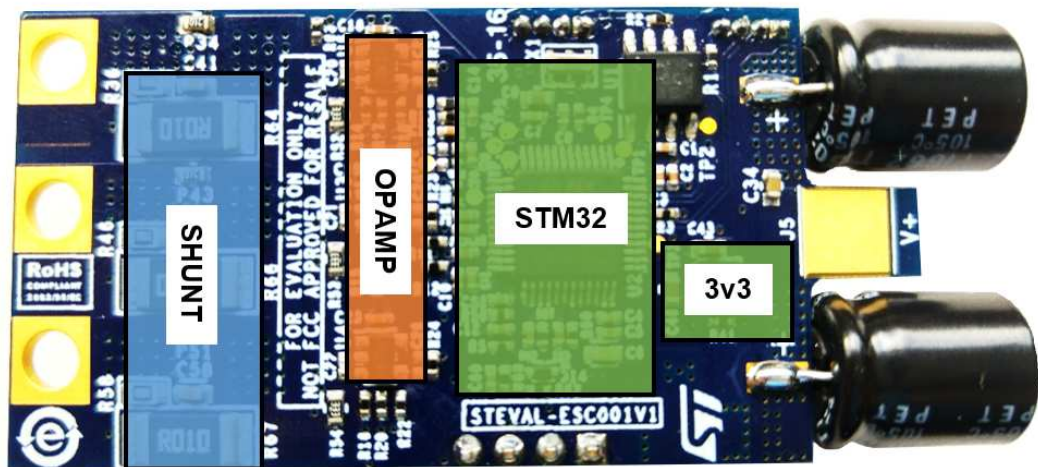

### 2.1.3 Board dimensions (29.1 x 58 mm)

Figure 8. STEVAL-ESC001V1 board dimensions (not including capacitors)

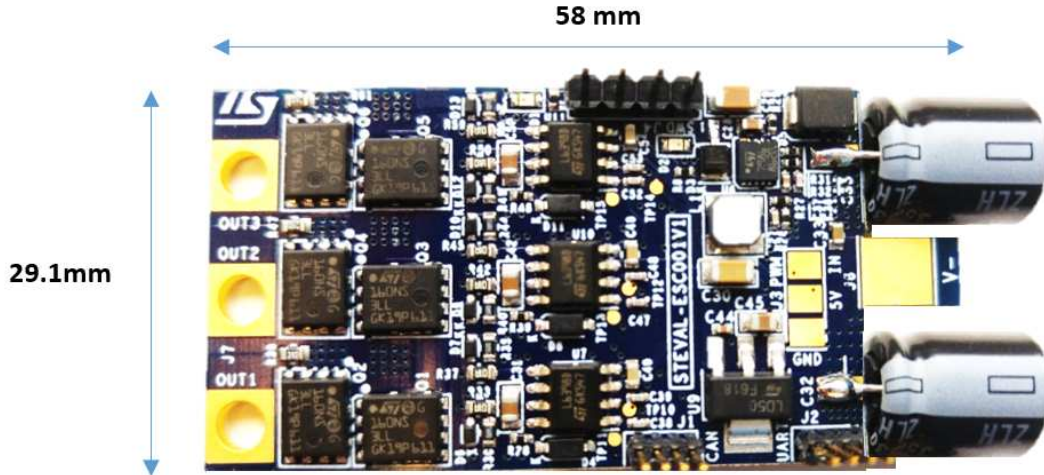

## 2.2 Communication, programming and command interfaces

The STEVAL-ESC001V1 features these communication interfaces:

- **CAN port (J1):** comes with an on-board transceiver; the J1 connector includes 3V3 and GND pins.
- **UART/I<sup>2</sup>C port (J2):** normally used for serial communication between the ESC board and a PC; ST MC Workbench can be connected with the STM32, adding an external circuit (requires USB/RS232 converter-3v3 level)

Figure 9. UART TX/RX (3v3 level)



- **PWM signal input (J3):** connects with an external board (e.g., flight control unit), to receive commands; the signal level (at 3v3) sets the motor speed according to the Ton duration (i.e., 1060  $\mu$ s for min. speed and 1860  $\mu$ s for max. speed). Other pins are for GND and a +5Vdc power line to supply an external board
- **SWD debug port (J4):** provides the SWD connection between the STM32 and ST-LINK programmer; other pins like 3V3 and GND are available.

## 2.3 STM32 pinout for motor control

Table 1. Main STM32 pinout for motor control

Pin	Default	Signal	Solder Bridge
1	VBAT	3V3	
2	PC13/TAMP/RTC	TP4	
3	PC14	N.C.	



Pin	Default	Signal	Solder Bridge
4	PC15	N.C.	
5	PF0/OSC-IN	OSC 8Mhz	
6	PF1/OSC-OUT	OSC 8Mhz	R4
7	NRST	RESET	
8	VSSA/VREF-	GND	
9	VDDA/VREF+	3V3	
10	PA0-WKUP	Curr_fdbk1	
11	PA1	Curr_fdbk2	
12	PA2	Curr_fdbk3	
13	PA3	Temperature feedback	
14	PA4	VREF, DAC1, TP8	R6 N.M.
15	PA5	DAC2, TP9	
16	PA6	N.C.	
17	PA7	Vshunt_1_filtered	
18	PB0	Vshunt_2_filtered	
19	PB1	TIM1_CH3N	
20	PB2	STATUS	
21	PB10	N.C.	
22	PB11	Vshunt_3_filtered	
23	VSS1	GND	
24	VDD1	3V3	
25	PB12	PHASE_1	
26	PB13	VBUS	R5
27	PB14	PHASE_2	
28	PB15	PHASE_3	
29	PA8	TIM1_CH1	
30	PA9	TIM1_CH2	R51
31	PA10	TIM1_CH3	
32	PA11	TIM1_CH1N	
33	PA12	TIM1_CH2N	
34	PA13	SWDIO	
35	VSS2	GND	
36	VDD2	3V3	
37	PA14	SWCLK	
38	PA15	INPUT	
39	PB3	N.C.	
40	PB4	TP3	
41	PB5	N.C.	
42	PB6	USART1_TX/I2C1_SCL	
43	PB7	USART1_RX/I2C1_SDA	
44	BOOT0	BOOT0	R3

Pin	Default	Signal	Solder Bridge
45	PB8	CAN_RX	
46	PB9	CAN_TX	
47	VSS		
48	VDD		

**Table 2. Input/output terminals**

Screw Terminal	Function
J5/J6	Li-Po battery power input (3S-6S)
J7	3-PH Motor connector

### 3 Initializing and using the STEVAL-ESC001V1 ESC board

**Step 1.** Connect the ST-LINK/V2 programmer to the J4 connector on the board.

**Table 3.** Relationship between the STEVAL board SWD pinout and SWD on ST-Link/V2 programmer

Pin no. in STLINK	ST-LINK/V2 connector	ST-LINK/V2 function	Target connection (SWD)	Pin no. in STEVAL-ESC001V1 (J4 connector)
1	VAPP	Target VCC	MCU VDD	1
2	VAPP	Target VCC	MCU VDD	1
6	GND			4
7		SW IO	SWDIO	3
9		SW CLK	SWCLK	2

**Figure 10.** STEVAL-ESC001V1 connection for MCU programming

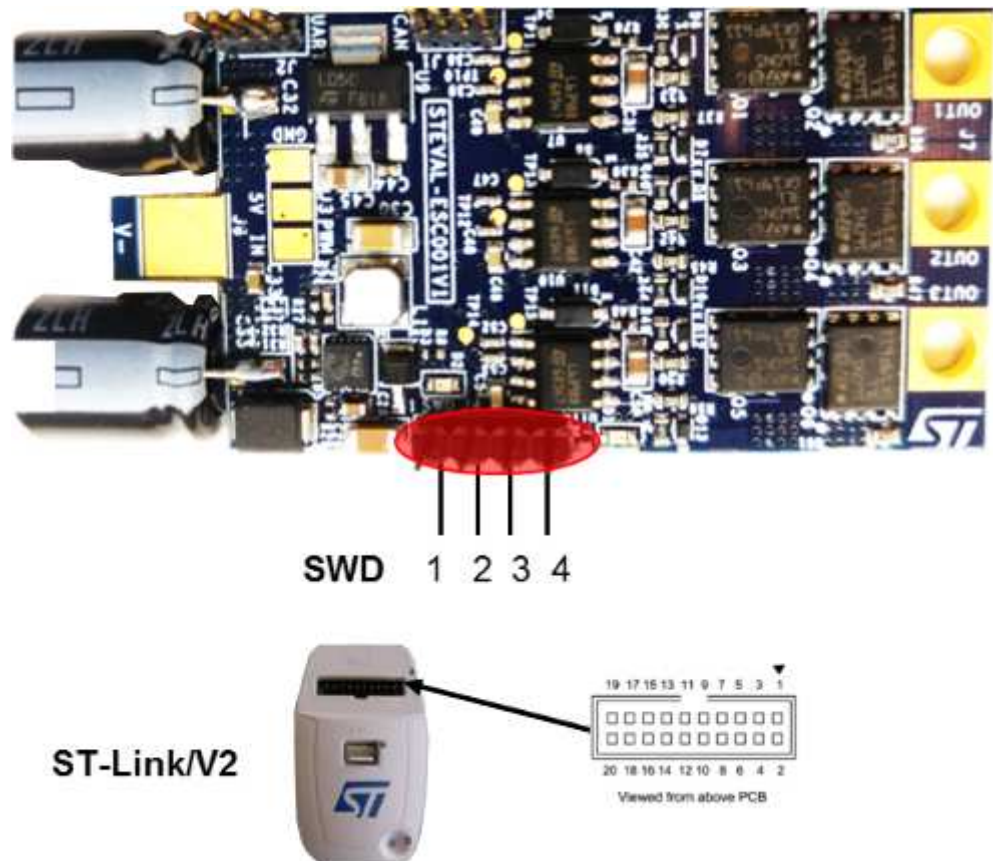

- Step 2.** Set the SWD interface in the IDE tool.

**Figure 11. Sample SWD configuration on IAR tool**

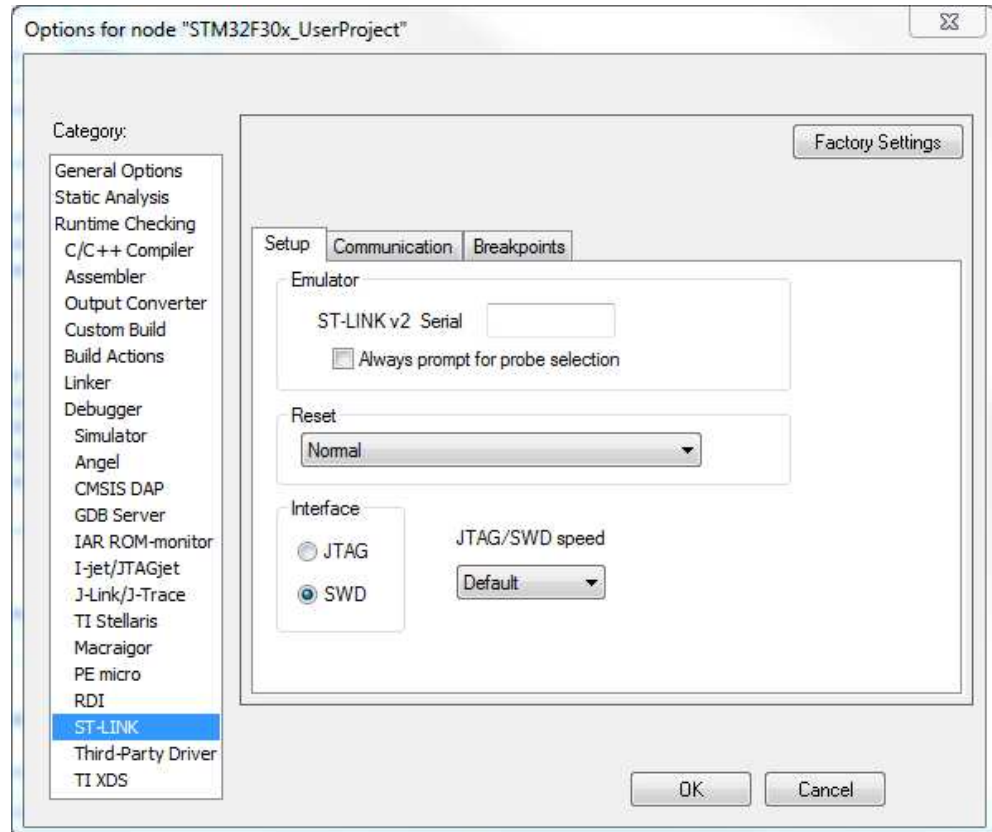

- Step 3.** Solder the three motor wires U,V,W at the motor connector with no particular color sequence. As shown in [Figure 12. STEVAL-ESC001V1 input/output connection](#), the right side is for the motor connection with three pads provided for soldering.
- Step 4.** Solder the PWM input at J3 connector. The INPUT pin level must not exceed 3V3.

**Step 5.** Connect the STEVAL-ESC001V1 with a Li-Po battery (or DC power supply: min 3S – max 6S) with the right polarity and turn ON.

The input connector has two large pads for soldering: the top layer for GND and bottom for Vdc+. A transil device prevents damage in case of reverse polarity.

**Figure 12.** STEVAL-ESC001V1 input/output connection

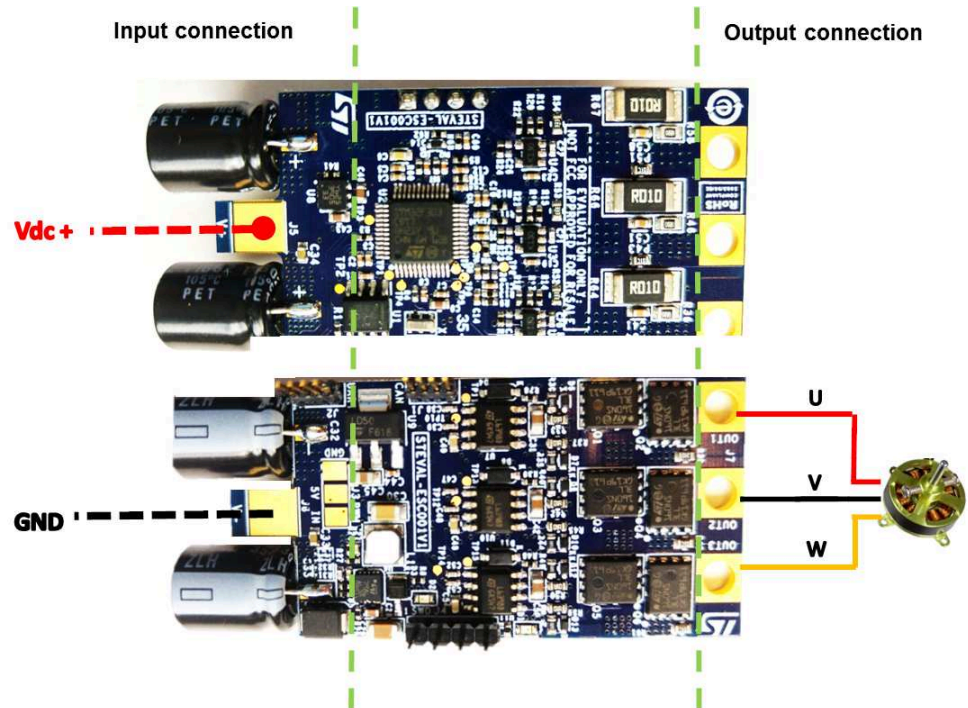

**Step 6.** Verify if the green led is turned on.

**Step 7.** Open ST ST Motor Control Workbench.

**Figure 13.** ST MC Workbench



**Step 8.** Follow the instructions included in the readme file to compile/upload the example project.



## 4 Schematic diagrams

Figure 14. STEVAL-ESC001V1 circuit schematic (1 of 4)

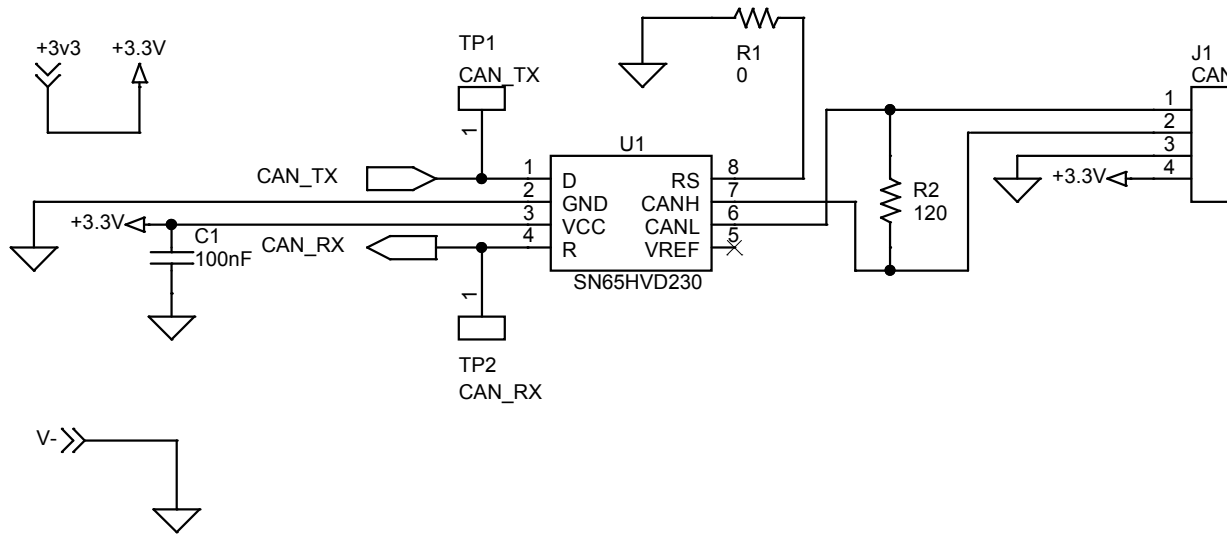

Figure 15. STEVAL-ESC001V1 circuit schematic (2 of 4)

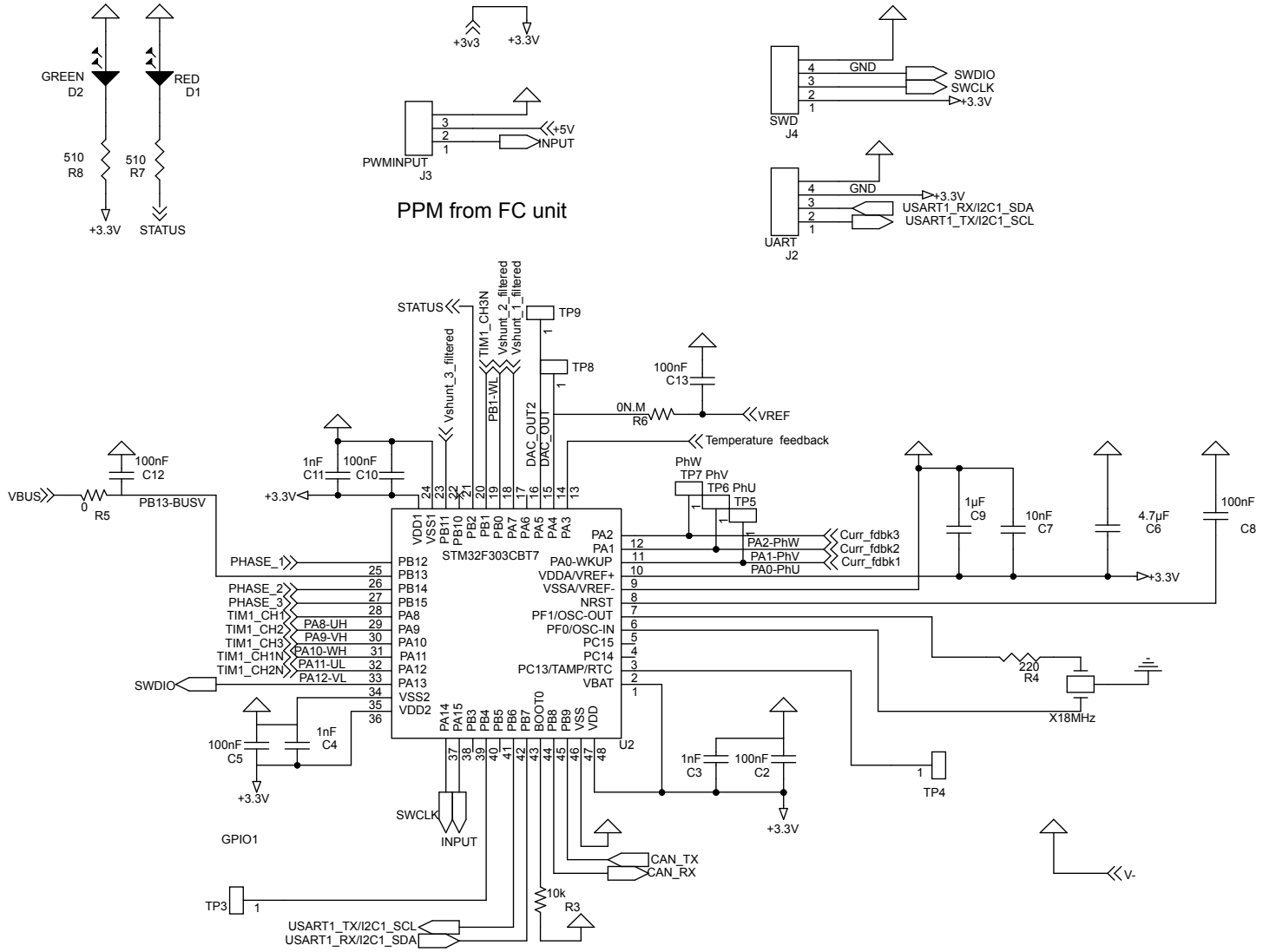

Figure 16. STEVAL-ESC001V1 circuit schematic (3 of 4)

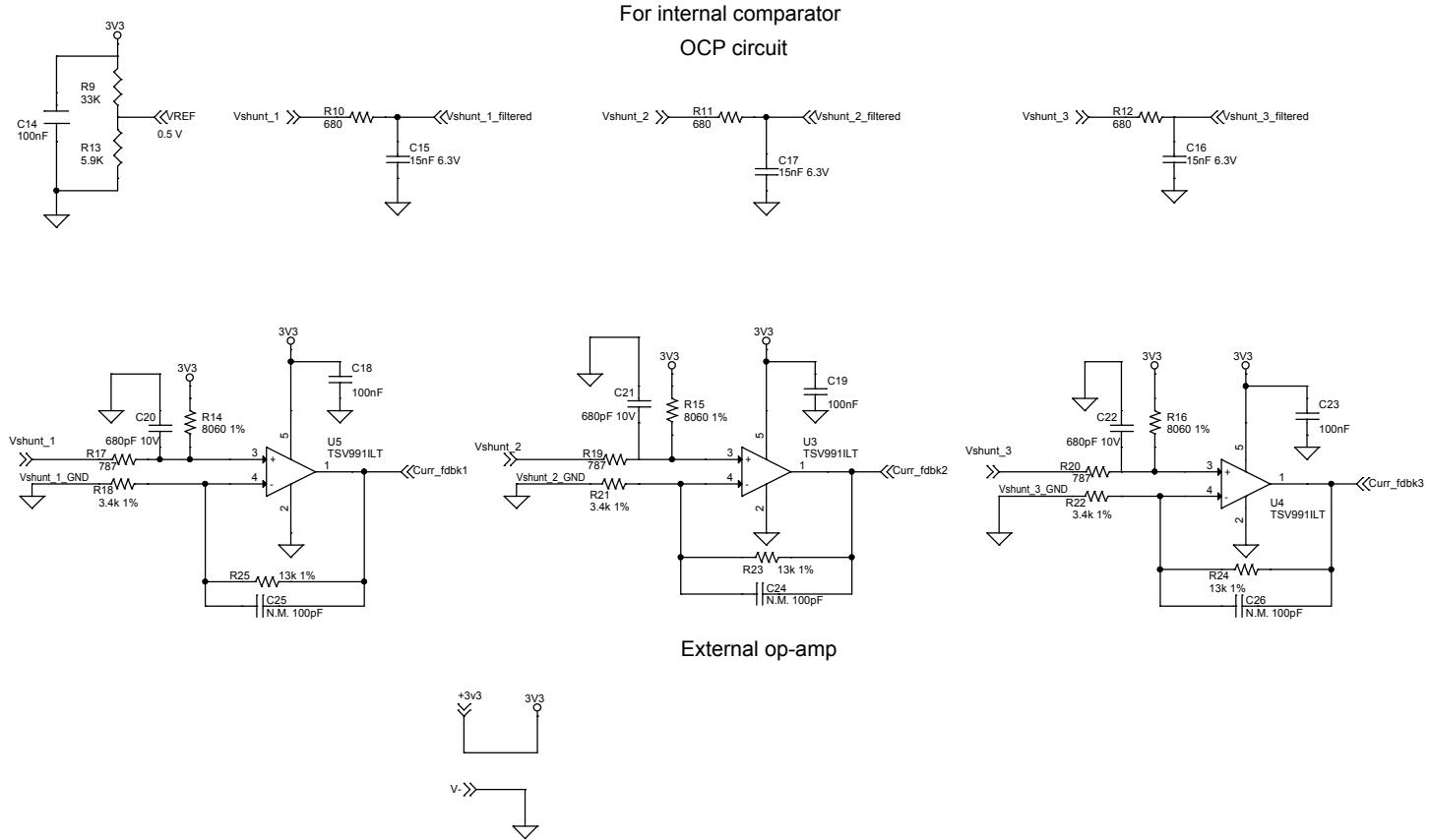
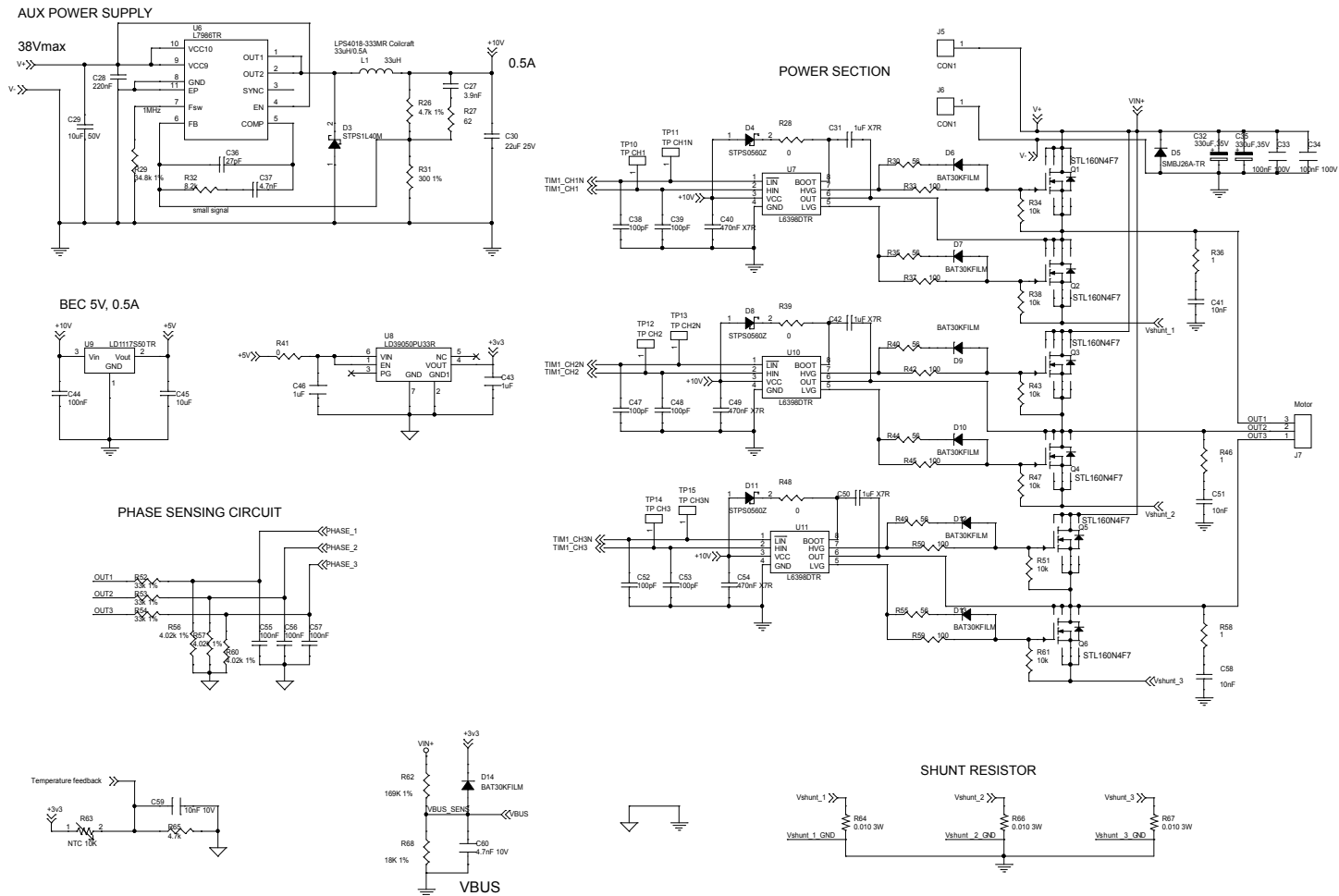

Figure 17. STEVAL-ESC001V1 circuit schematic (4 of 4)



## 5 Bill of materials

**Table 4. STEVAL-ESC001V1 bill of materials**

Item	Q.ty	Ref.	Part / Value	Description	Manufacturer	Order code
1	15	C1, C2, C5, C8, C10 C12, C13, C14, C18 C19, C23, C44, C55 C56, C57	100 nF 25 V ±10% X7R	Ceramic capacitor	any	
2	3	C3, C4, C11	1 nF 50 V ±10% X7R	Ceramic capacitor	any	
3	1	C6	4.7 µF 10 V ±10% X5R	Ceramic capacitor	Murata	GRM188R61A475KE15D
4	2	C7, C59	10 nF 50 V ±10% X7R	Ceramic capacitor	any	
5	3	C9, C43, C46	1 µF 16 V ±10% X7R	Ceramic capacitor	TDK	C1608X7R1C105K080AC
6	3	C15, C16, C17	15 nF 10 V ±10% X7R	Ceramic capacitor	any	
7	3	C20, C21, C22	680 pF 10 V ±5% C0G	Ceramic capacitor	any	
8	3	C24, C25, C26	100 pF ±0%	Capacitors (not mounted)		
9	1	C27	3.9 nF 50 V ±10% X7R	Ceramic capacitor	any	
10	1	C28	220 nF 50 V ±10% X7R	Ceramic capacitor	any	
11	1	C29	10 µF 50 V ±10% X5R	Ceramic capacitor	any	
12	1	C30	22 µF 25 V ±10% X5R	Ceramic capacitor	any	
13	3	C31, C42, C50	1 µF X7R 50 V ±10%	Ceramic capacitor	any	
14	2	C32, C35	330 µF, 35 V ±20%	Electrolytic capacitor	Rubycon	35ZLH330MEFC10X12.5
15	2	C33, C34	100 nF 100 V ±10% X7R	Ceramic capacitor	any	
16	1	C36	27 pF 50 V ±5% C0G	Ceramic capacitor	any	
17	2	C37, C60	4.7 nF 16 V ±10% X7R	Ceramic capacitor	any	
18	6	C38, C39, C47 C48, C52, C53	100 pF 16 V ±10% X7R	Ceramic capacitor	any	
19	3	C40, C49, C54	470 nF 25 V ±10% X7R	Ceramic capacitor	any	
20	3	C41, C51, C58	10 nF 100 V ±10% X7R	Ceramic capacitor	any	
21	1	C45	10 µF 25 V ±10% X7R	Ceramic capacitor	Murata	GRM21BR61E106KA73L
22	1	D1		Red LED	Lite-on	LTST-C193KRKT-5A
23	1	D2		Red LED	Lite-on	LTST-C193KGKT-5A



Item	Q.ty	Ref.	Part / Value	Description	Manufacturer	Order code
24	1	D3	40 V 1 A	Low drop power Schottky diode	ST	<a href="#">STPS1L40M</a>
25	3	D4, D8, D11	60V/0.5A	Power Schottky diode	ST	<a href="#">STPS0560Z</a>
26	1	D5		Transil	ST	<a href="#">SMBJ26A-TR</a>
27	7	D6, D7, D9, D10 D12, D13, D14	30V, 0.3A	Schottky diode	ST	<a href="#">BAT30KFILM</a>
28	2	J1, J2		CAN, UART: 4 WAYS STRIP LINE - MALE 1.27mm	any	
29	1	J3		PWM INPUT: 3 way wires welding		
30	1	J4		SWD: 4-way strip line - male 2.54mm	any	
31	2	J5, J6		CON1 - Input power connector: 1-way wire welding		
32	1	J7		Motor Connetor: 3-way wire welding		
33	1	L1	33 $\mu$ H 0.5 A	Power inductor	Coilcraft	<a href="#">LPS4018-333MRB</a>
34	6	Q1, Q2, Q3 Q4, Q5, Q6	30 V, 160 A	Power MOSFETs	ST	<a href="#">STL160NS3LLH7</a>
			40 V, 160 A			<a href="#">STL160N4F7</a>
35	6	R1, R5, R28 R39, R41, R48	0 62.5 mW $\pm$ 5%	SMD resistor	any	
36	1	R2	120 62.5 mW $\pm$ 5%	SMD resistor	any	
37	1	R3	10 k 62.5 mW $\pm$ 5%	SMD resistor	any	
38	1	R4	220 62.5 mW $\pm$ 5%	SMD resistor	any	
39	1	R6	62.5 mW $\pm$ 5%	SMD resistor	any	
40	2	R7, R8	510 62.5 mW $\pm$ 5%	SMD resistor	any	
41	1	R9	33 K 62.5 mW $\pm$ 5%	SMD resistor	any	
42	3	R10, R11, R12	680 62.5 mW $\pm$ 5%	SMD resistor	any	
43	1	R13	5.9 K 62.5 mW $\pm$ 5%	SMD resistor	any	
44	3	R14, R15, R16	8.06 k 62.5 mW $\pm$ 1%	SMD resistor	Vishay	<a href="#">CRCW04028K06FKED</a>
45	3	R17, R19, R20	787 62.5 mW $\pm$ 1%	SMD resistor	Panasonic	<a href="#">ERJ2RKF7870X</a>
46	3	R18, R21, R22	3.4 k 62.5 mW $\pm$ 1%	SMD resistor	Panasonic	<a href="#">ERJ2RKF3401X</a>
47	2	R23, R24, R25	13 k 62.5 mW $\pm$ 1%	SMD resistor	any	
48	1	R26	4.7 k 62.5 mW $\pm$ 1%	SMD resistor	any	

Item	Q.ty	Ref.	Part / Value	Description	Manufacturer	Order code
49	1	R65	4.7 k 62.5 mW ±5%	SMD resistor	any	
50	1	R27	62 62.5 mW ±1%	SMD resistor	any	
51	1	R29	34.8 k 62.5 mW ±1%	SMD resistor	any	
52	6	R30, R35, R40 R44, R49, R55	56 0.1 W ±5%	SMD resistor	any	
53	1	R31	300 62.5 mW ±1%	SMD resistor	any	
54	1	R32	8.2 k 62.5 mW ±1%	SMD resistor	any	
55	6	R33, R37, R42 R45, R50, R59	100 0.1 W ±5%	SMD resistor	any	
56	6	R34, R38, R43 R47, R51, R61	10 k 0.1 W ±5%	SMD resistor	any	
57	3	R36, R46, R58	1 0.125 W ±5%	SMD resistor	any	
58	3	R52, R53, R54	33 k 0.1 W ±1%	SMD resistor	any	
59	3	R56, R57, R60	4.02 k 62.5 mW ±1%	SMD resistor	any	
60	1	R62	169 K 62.5 mW ±1%	SMD resistor	any	
61	1	R63	NTC 10 K ±1%	NTC Thermistor	TDK	NTCG103JF103F
62	3	R64, R66, R67	0.01 3 W ±1%	10 mOhm shunt resistor	Bourns	CRA2512-FZ-R010ELF
					KOA Speer	TLR3APDTE10L0F50
63	1	R68	18 K 62.5 mW ±1%	SMD resistor	any	
64	1	TP1, TP2, TP3, TP4 TP5, TP6, TP7, TP8 TP9, TP10, TP11 TP12, TP13, TP14 TP15	SMD PAD 1 mm ±0%	Test point	any	
65	1	U1		CAN transceiver	TI	SN65HVD230D
66	1	U2		32bit MCU	ST	STM32F303CBT7
67	3	U3, U4, U5		Rail-to-rail input/ output 20 MHz GBP operational amplifiers	ST	TSV9911LT
68	1	U6		3 A step-down switching regulator	ST	L7986TR
69	3	U7, U10, U11		High voltage high and low-side driver	ST	L6398D
70	1	U8		Low drop vo ltage regulator	ST	LD39050PU33R
71	1	U9		Low drop vo ltage regulator	ST	LD1117S50TR

Item	Q.ty	Ref.	Part / Value	Description	Manufacturer	Order code
72	1	X1		Resonators 8 Mhz	Murata	CSTCE8M00G55-R0

## Revision history

**Table 5. Document revision history**

Date	Version	Changes
07-Apr-2017	1	Initial release.
13-Nov-2018	2	Updated Introduction and Section 5 Bill of materials. Added references to STL160N4F7.
10-Nov-2021	3	Updated Introduction, <a href="#">Section 1 Main features</a> , and <a href="#">Section 3 Initializing and using the STEVAL-ESC001V1 ESC board</a> .

## Contents

<b>1</b>	<b>Main features</b> .....	<b>2</b>
1.1	Target application .....	2
<b>2</b>	<b>Description</b> .....	<b>3</b>
2.1	STEVAL-ESC001V1 hardware overview .....	5
2.1.1	STEVAL-ESC001V1 top side components .....	5
2.1.2	STEVAL-ESC001V1 bottom side components .....	6
2.1.3	Board dimensions (29.1 x 58 mm) .....	7
2.2	Communication, programming and command interfaces .....	7
2.3	STM32 pinout for motor control .....	7
<b>3</b>	<b>Initializing and using the STEVAL-ESC001V1 ESC board</b> .....	<b>10</b>
<b>4</b>	<b>Schematic diagrams</b> .....	<b>13</b>
<b>5</b>	<b>Bill of materials</b> .....	<b>17</b>
	<b>Revision history</b> .....	<b>21</b>



## List of figures

<b>Figure 1.</b>	STEVAL-ESC001V1 evaluation board . . . . .	1
<b>Figure 2.</b>	STEVAL-ESC001V1 target applications . . . . .	2
<b>Figure 3.</b>	System structure overview . . . . .	4
<b>Figure 4.</b>	Typical quadcopter architecture . . . . .	4
<b>Figure 5.</b>	STEVAL-ESC001V1 block diagram . . . . .	5
<b>Figure 6.</b>	Top side features . . . . .	5
<b>Figure 7.</b>	Bottom side features . . . . .	6
<b>Figure 8.</b>	STEVAL-ESC001V1 board dimensions (not including capacitors) . . . . .	7
<b>Figure 9.</b>	UART TX/RX (3v3 level) . . . . .	7
<b>Figure 10.</b>	STEVAL-ESC001V1 connection for MCU programming . . . . .	10
<b>Figure 11.</b>	Sample SWD configuration on IAR tool . . . . .	11
<b>Figure 12.</b>	STEVAL-ESC001V1 input/output connection . . . . .	12
<b>Figure 13.</b>	ST MC Workbench . . . . .	12
<b>Figure 14.</b>	STEVAL-ESC001V1 circuit schematic (1 of 4). . . . .	13
<b>Figure 15.</b>	STEVAL-ESC001V1 circuit schematic (2 of 4). . . . .	14
<b>Figure 16.</b>	STEVAL-ESC001V1 circuit schematic (3 of 4). . . . .	15
<b>Figure 17.</b>	STEVAL-ESC001V1 circuit schematic (4 of 4). . . . .	16

## List of tables

<b>Table 1.</b>	Main STM32 pinout for motor control . . . . .	7
<b>Table 2.</b>	Input/output terminals . . . . .	9
<b>Table 3.</b>	Relationship between the STEVAL board SWD pinout and SWD on ST-Link/V2 programmer. . . . .	10
<b>Table 4.</b>	STEVAL-ESC001V1 bill of materials. . . . .	17
<b>Table 5.</b>	Document revision history . . . . .	21

**IMPORTANT NOTICE – PLEASE READ CAREFULLY**

STMicroelectronics NV and its subsidiaries (“ST”) reserve the right to make changes, corrections, enhancements, modifications, and improvements to ST products and/or to this document at any time without notice. Purchasers should obtain the latest relevant information on ST products before placing orders. ST products are sold pursuant to ST’s terms and conditions of sale in place at the time of order acknowledgement.

Purchasers are solely responsible for the choice, selection, and use of ST products and ST assumes no liability for application assistance or the design of Purchasers’ products.

No license, express or implied, to any intellectual property right is granted by ST herein.

Resale of ST products with provisions different from the information set forth herein shall void any warranty granted by ST for such product.

ST and the ST logo are trademarks of ST. For additional information about ST trademarks, please refer to [www.st.com/trademarks](http://www.st.com/trademarks). All other product or service names are the property of their respective owners.

Information in this document supersedes and replaces information previously supplied in any prior versions of this document.

© 2021 STMicroelectronics – All rights reserved