



HESTORE.HU

elektronikai alkatrész áruház

EN: This Datasheet is presented by the manufacturer.

Please visit our website for pricing and availability at www.hestore.hu.

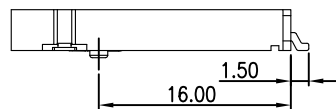
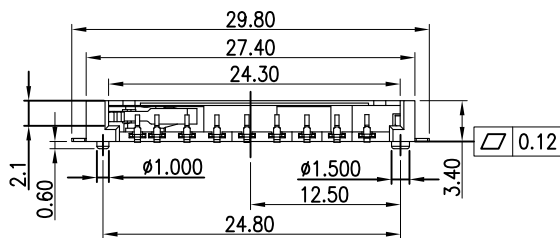
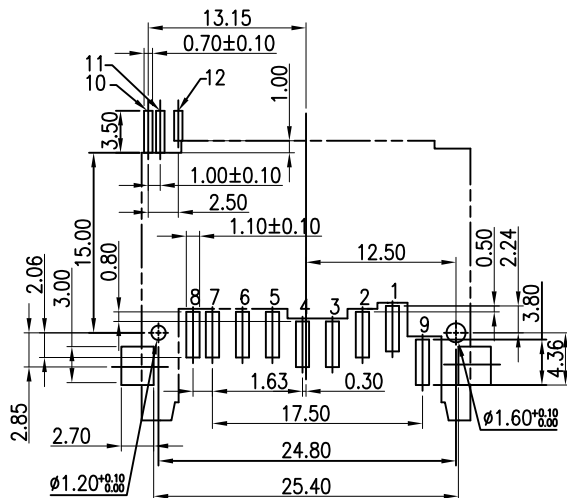
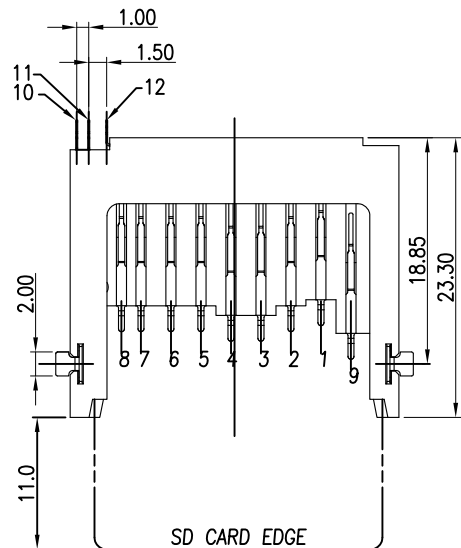

SD CARD PIN DESIGN

Pin No.	Name	Description
1#	CD/DAT3	Card detect/Data I/O
2#	CMD	Command
3#	VSS1	Ground
4#	VDD	Power
5#	CLK	Clock
6#	VSS2	Ground
7#	DAT0	Data I/O
8#	DAT1	Data I/O
9#	DAT2	Data I/O

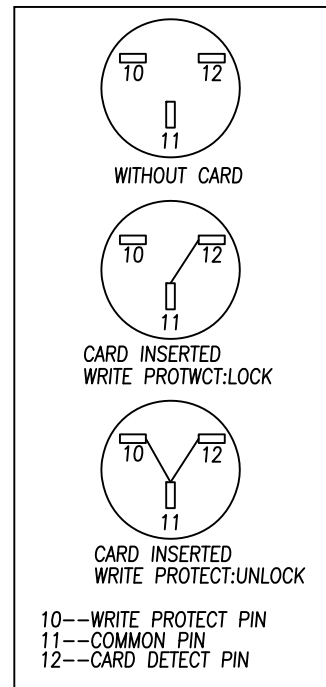
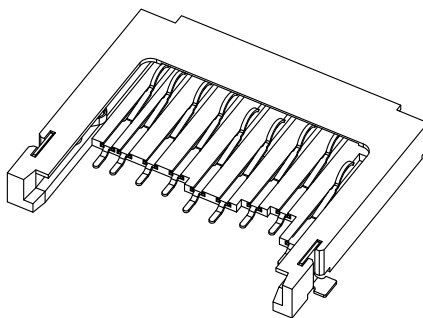

- MATERIAL**
HOUSING: HIGH TEMPERATURE THERMOPLASTIC.
CONTACT: COPPER ALLOY.
SHELL: COPPER ALLOY.
- PLATING**
CONTACT AREA: 3u" and 10u" GOLD PLATED OVER Ni.
SOLDER TAIL: 100 u" MIN Sn PLATED OVER Ni.
SHELL SOLDER AREA: GOLD PLATED OVER Ni.
CONTACT NUMBER: 9 PIN
- RATING**
CURRENT RATING: 0.5A
VOLTAGE RATING: 250VRM
OPERATING TEMPERATURE: -25°C~90°C
- SPECIFICATION**
CONTACT RESISTANCE: 100mΩ Max
DIELECTRIC WITHSTANDING VOLTAGE: 500VAC
INSULATION RESISTANCE: 100MΩ Min
INSERTION FORCE: 40N MAX.
SEPARATION FORCE: 2N MIN.

104B-T X A 0-R
1 2 3 4

- Type
T: TOP Mount
3. Stand Off
A: 0mm
- Contact Plating
A: 10u" Gold Plating
B: 3u" Gold Plating
4. ROHS

UNLESS OTHERWISE SPECIFIED TOLERANCE	
ANG.	±5°
0.	±
.0	±0.25
.00	±0.20
SCALE: AS SHOWN	UNIT: mm
DRAWN willis	2007/1/18
CHECKED	/ /
APPROVED	/ /
SIZE A4	REV.



ATTEND TECHNOLOGY INC.

www.attend.com.tw

DRAWN NAME:	SD Socket Top Mount
PRODUCT NO.	104B-TXA0-R
FILE NAME:	104B-TXA0-R

REV.	DESCRIPTION	DATE	SIZE	REV.
1			A4	
2				
3				
4				
5				
6				
7				
8				
9				
10				