



**HESTORE.HU**

elektronikai alkatrész áruház

**EN:** This Datasheet is presented by the manufacturer.

Please visit our website for pricing and availability at [www.hestore.hu](http://www.hestore.hu).

## Very low-dropout voltage regulator with inhibit function

Datasheet - production data

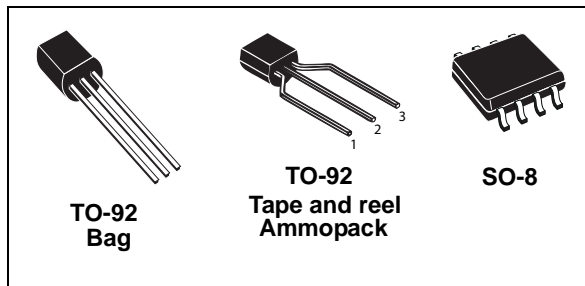

### Description

The LEXX is a very low-dropout voltage regulator available in SO-8, TO-92 packages and over a wide range of output voltages.

The very low-dropout voltage (0.2 V) and low quiescent current make it particularly suitable for low-noise, low-power applications and in battery-powered systems.

This device is pin-to-pin compatible with the L78L series. Furthermore, in the 8-pin configuration (SO-8), it uses a shutdown logic control (pin 5, TTL compatible). This means that when the device is used as a local regulator, a part of the board can be put in standby, decreasing the total power consumption. In the three-terminal configuration (TO-92), the device is always in on-state. It requires a 2.2  $\mu$ F capacitor for stability, reducing the component size and cost.

### Features

- Very low-dropout voltage (0.2 V typ.)
- Very low quiescent current (typ. 50  $\mu$ A in OFF mode, 0.5 mA in ON mode, no load)
- Output current up to 100 mA
- Output voltages: 3 V, 3.3 V, 4.5 V, 5 V, 8 V
- Internal current and thermal limit
- Small 2.2  $\mu$ F capacitor for stability
- Available in  $\pm 1\%$  (A) or  $\pm 2\%$  (C) selection at 25  $^{\circ}$ C
- Supply voltage rejection: 80 dB (typ.)
- Temperature range: - 40 to 125  $^{\circ}$ C

Table 1. Device summary

Order codes				Output voltages
SO-8	TO-92 (bag)	TO-92 (ammopack)	TO-92 (tape and reel)	
			LE30ABZ-TR	3 V
LE30CD-TR				3 V
LE33CD-TR	LE33CZ	LE33CZ-AP	LE33CZ-TR	3.3 V
LE45CD-TR				4.5 V
LE50ABD-TR		LE33ABZ-AP		5 V
LE50CD-TR				5 V
LE80CD-TR				8 V

# Contents

1	Diagram .....	3
2	Pin configuration .....	4
3	Maximum ratings .....	5
4	Electrical characteristics .....	6
5	Typical performance characteristics .....	13
6	Package mechanical data .....	16
7	Packaging information .....	20
8	Revision history .....	26

# 1 Diagram

Figure 1. Block diagram

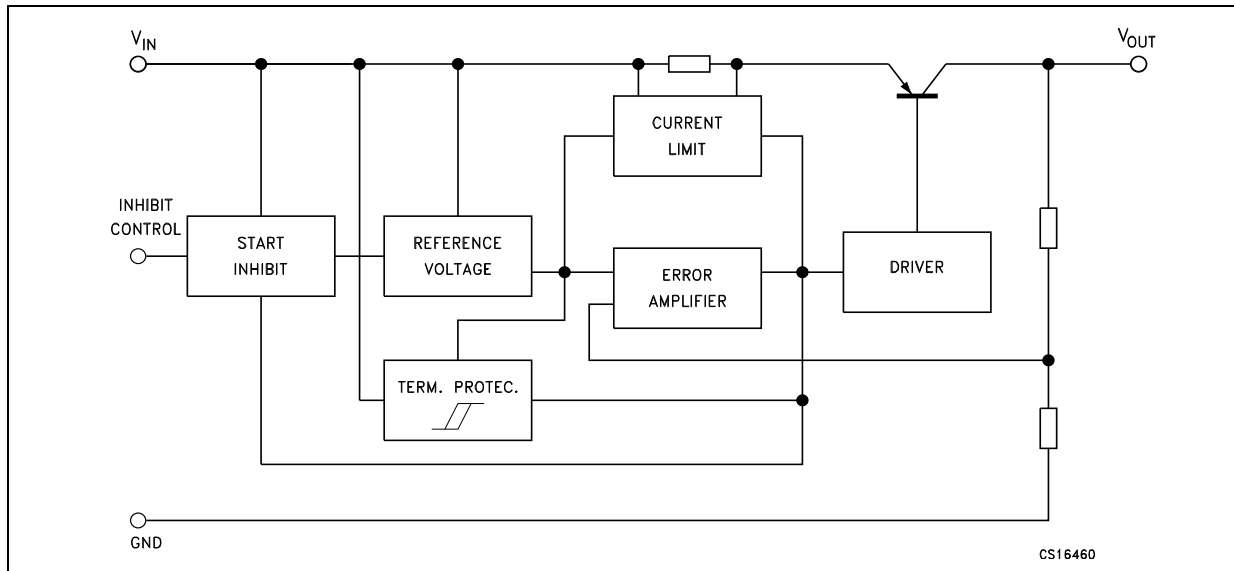

## 2 Pin configuration

Figure 2. Pin connections (SO-8 top view, TO-92 bottom view)

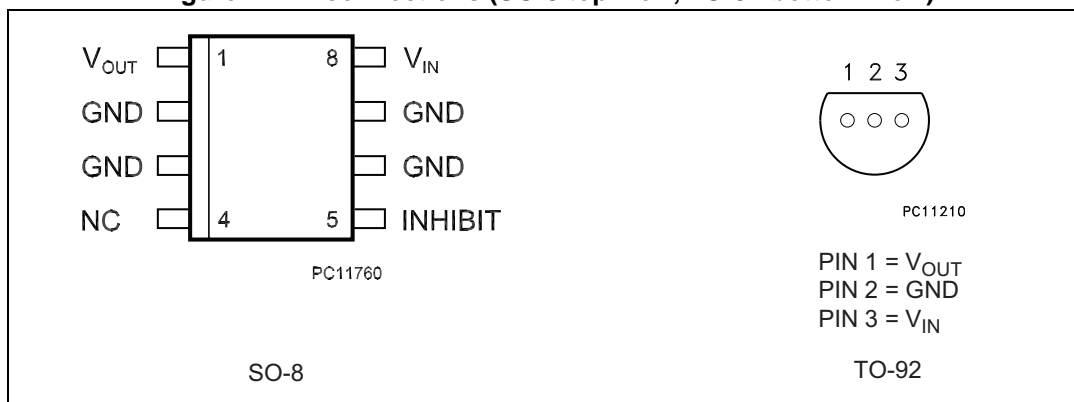

### 3 Maximum ratings

**Table 2. Absolute maximum ratings**

Symbol	Parameter	Value	Unit
$V_I$	DC input voltage	20	V
$I_O$	Output current	Internally limited <sup>(1)</sup>	
$P_{TOT}$	Power dissipation	Internally limited	
$T_{STG}$	Storage temperature range	-65 to 150	°C
$T_{OP}$	Operating junction temperature range	-40 to 125	°C

1. Our SO-8 package, used for voltage regulators, is modified internally to have pins 2, 3, 6 and 7 electrically fused to the die attach pad. This frame decreases the total thermal resistance of the package and increases its ability to dissipate power when an appropriate area of copper on the printed circuit board is available for heatsinking. The external dimensions are the same as SO-8 standard.

**Table 3. Thermal data**

Symbol	Parameter	SO-8	TO-92	Unit
$R_{thJC}$	Thermal resistance junction-case	20		°C/W
$R_{thJA}$	Thermal resistance junction-ambient	55	200	°C/W

**Figure 3. Test circuit**

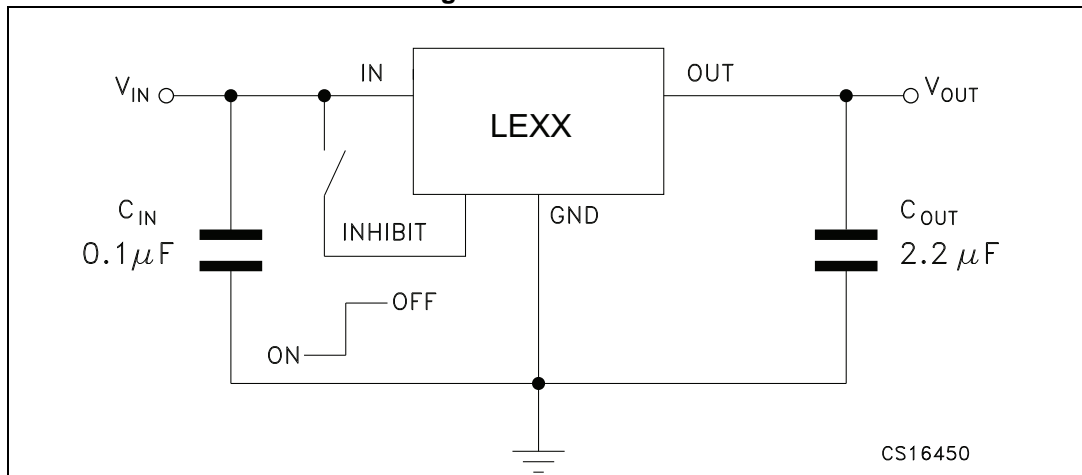

**Note:** *If the INHIBIT pin is left floating, the regulator is in ON mode. However, when the inhibit function is not used, it should be grounded to avoid any noise.*

## 4 Electrical characteristics

Refer to test circuits,  $T_J = 25\text{ °C}$ ,  $C_I = 0.1\text{ }\mu\text{F}$ ,  $C_O = 2.2\text{ }\mu\text{F}$  unless otherwise specified.

**Table 4. LE30AB electrical characteristics**

Symbol	Parameter	Test conditions	Min.	Typ.	Max.	Unit
$V_O$	Output voltage	$I_O = 10\text{ mA}$ , $V_I = 5\text{ V}$	2.970	3	3.030	V
		$I_O = 10\text{ mA}$ , $V_I = 5\text{ V}$ , $T_J = -25\text{ to }85\text{ °C}$	2.940		3.060	
$V_I$	Operating input voltage	$I_O = 100\text{ mA}$			18	V
$I_O$	Output current limit		150			mA
$\Delta V_O$	Line regulation	$V_I = 3.7\text{ to }18\text{ V}$ , $I_O = 0.5\text{ mA}$		3	15	mV
$\Delta V_O$	Load regulation	$V_I = 4\text{ V}$ , $I_O = 0.5\text{ to }100\text{ mA}$		3	15	mV
$I_d$	Quiescent current	$V_I = 4\text{ to }18\text{ V}$ , $I_O = 0\text{ mA}$	ON mode	0.5	1	mA
		$V_I = 4\text{ to }18\text{ V}$ , $I_O = 100\text{ mA}$		1.5	3	
		$V_I = 6\text{ V}$	OFF mode	50	100	$\mu\text{A}$
SVR	Supply voltage rejection	$I_O = 5\text{ mA}$ , $V_I = 5 \pm 1\text{ V}$	$f = 120\text{ Hz}$	81		dB
			$f = 1\text{ kHz}$	76		
			$f = 10\text{ kHz}$	60		
eN	Output noise voltage	$B = 10\text{ Hz to }100\text{ kHz}$		50		$\mu\text{V}$
$V_d$	Dropout voltage	$I_O = 100\text{ mA}$		0.2	0.4	V
		$I_O = 100\text{ mA}$ , $T_J = -40\text{ to }125\text{ °C}$			0.5	
$V_{IL}$	Control input logic low	$T_J = -40\text{ to }125\text{ °C}$			0.8	V
$V_{IH}$	Control input logic high	$T_J = -40\text{ to }125\text{ °C}$	2			V
$I_I$	Control input current	$V_I = 6\text{ V}$ , $V_C = 6\text{ V}$		10		$\mu\text{A}$
$C_O$	Output bypass capacitance	$\text{ESR} = 0.1\text{ to }10\text{ }\Omega$ , $I_O = 0\text{ to }100\text{ mA}$	2	10		$\mu\text{F}$

Refer to test circuits,  $T_J = 25\text{ °C}$ ,  $C_I = 0.1\text{ }\mu\text{F}$ ,  $C_O = 2.2\text{ }\mu\text{F}$  unless otherwise specified.

**Table 5. LE30C electrical characteristics**

Symbol	Parameter	Test conditions	Min.	Typ.	Max.	Unit
$V_O$	Output voltage	$I_O = 10\text{ mA}$ , $V_I = 5\text{ V}$	2.940	3	3.060	V
		$I_O = 10\text{ mA}$ , $V_I = 5\text{ V}$ , $T_J = -25\text{ to }85\text{ °C}$	2.880		3.120	
$V_I$	Operating input voltage	$I_O = 100\text{ mA}$			18	V
$I_O$	Output current limit		150			mA
$\Delta V_O$	Line regulation	$V_I = 3.7\text{ to }18\text{ V}$ , $I_O = 0.5\text{ mA}$		3	20	mV
$\Delta V_O$	Load regulation	$V_I = 4\text{ V}$ , $I_O = 0.5\text{ to }100\text{ mA}$		3	25	mV
$I_d$	Quiescent current	$V_I = 4\text{ to }18\text{ V}$ , $I_O = 0\text{ mA}$	ON mode	0.5	1	mA
		$V_I = 4\text{ to }18\text{ V}$ , $I_O = 100\text{ mA}$		1.5	3	
		$V_I = 6\text{ V}$	OFF mode	50	100	$\mu\text{A}$
SVR	Supply voltage rejection	$I_O = 5\text{ mA}$ , $V_I = 5 \pm 1\text{ V}$	$f = 120\text{ Hz}$	81		dB
			$f = 1\text{ kHz}$	76		
			$f = 10\text{ kHz}$	60		
eN	Output noise voltage	$B = 10\text{ Hz to }100\text{ kHz}$		50		$\mu\text{V}$
$V_d$	Dropout voltage	$I_O = 100\text{ mA}$		0.2	0.4	V
		$I_O = 100\text{ mA}$ , $T_J = -40\text{ to }125\text{ °C}$			0.5	
$V_{IL}$	Control input logic low	$T_J = -40\text{ to }125\text{ °C}$			0.8	V
$V_{IH}$	Control input logic high	$T_J = -40\text{ to }125\text{ °C}$	2			V
$I_I$	Control input current	$V_I = 6\text{ V}$ , $V_C = 6\text{ V}$		10		$\mu\text{A}$
$C_O$	Output bypass capacitance	$\text{ESR} = 0.1\text{ to }10\text{ }\Omega$ , $I_O = 0\text{ to }100\text{ mA}$	2	10		$\mu\text{F}$



Refer to test circuits,  $T_J = 25\text{ °C}$ ,  $C_I = 0.1\text{ }\mu\text{F}$ ,  $C_O = 2.2\text{ }\mu\text{F}$  unless otherwise specified.

**Table 6. LE33C electrical characteristics**

Symbol	Parameter	Test conditions	Min.	Typ.	Max.	Unit
$V_O$	Output voltage	$I_O = 10\text{ mA}$ , $V_I = 5.3\text{ V}$	3.234	3.3	3.366	V
		$I_O = 10\text{ mA}$ , $V_I = 5.3\text{ V}$ , $T_J = -25\text{ to }85\text{ °C}$	3.168		3.432	
$V_I$	Operating input voltage	$I_O = 100\text{ mA}$			18	V
$I_O$	Output current limit		150			mA
$\Delta V_O$	Line regulation	$V_I = 4\text{ to }18\text{ V}$ , $I_O = 0.5\text{ mA}$		3	20	mV
$\Delta V_O$	Load regulation	$V_I = 4.3\text{ V}$ , $I_O = 0.5\text{ to }100\text{ mA}$		3	25	mV
$I_d$	Quiescent current	$V_I = 4.3\text{ to }18\text{ V}$ , $I_O = 0\text{ mA}$	ON mode	0.5	1	mA
		$V_I = 4.3\text{ to }18\text{ V}$ , $I_O = 100\text{ mA}$		1.5	3	
		$V_I = 6\text{ V}$	OFF mode	50	100	$\mu\text{A}$
SVR	Supply voltage rejection	$I_O = 5\text{ mA}$ , $V_I = 5.3 \pm 1\text{ V}$	$f = 120\text{ Hz}$	80		dB
			$f = 1\text{ kHz}$	75		
			$f = 10\text{ kHz}$	60		
eN	Output noise voltage	$B = 10\text{ Hz to }100\text{ kHz}$		50		$\mu\text{V}$
$V_d$	Dropout voltage	$I_O = 100\text{ mA}$		0.2	0.4	V
		$I_O = 100\text{ mA}$ , $T_J = -40\text{ to }125\text{ °C}$			0.5	
$V_{IL}$	Control input logic low	$T_J = -40\text{ to }125\text{ °C}$			0.8	V
$V_{IH}$	Control input logic high	$T_J = -40\text{ to }125\text{ °C}$	2			V
$I_I$	Control input current	$V_I = 6\text{ V}$ , $V_C = 6\text{ V}$		10		$\mu\text{A}$
$C_O$	Output bypass capacitance	$\text{ESR} = 0.1\text{ to }10\text{ }\Omega$ , $I_O = 0\text{ to }100\text{ mA}$	2	10		$\mu\text{F}$

Refer to test circuits,  $T_J = 25\text{ °C}$ ,  $C_I = 0.1\text{ }\mu\text{F}$ ,  $C_O = 2.2\text{ }\mu\text{F}$  unless otherwise specified.

**Table 7. LE45C electrical characteristics**

Symbol	Parameter	Test conditions	Min.	Typ.	Max.	Unit
$V_O$	Output voltage	$I_O = 10\text{ mA}$ , $V_I = 6.5\text{ V}$	4.41	4.5	4.59	V
		$I_O = 10\text{ mA}$ , $V_I = 6.5\text{ V}$ , $T_J = -25\text{ to }85\text{ °C}$	4.32		4.68	
$V_I$	Operating input voltage	$I_O = 100\text{ mA}$			18	V
$I_O$	Output current limit		150			mA
$\Delta V_O$	Line regulation	$V_I = 5.2\text{ to }18\text{ V}$ , $I_O = 0.5\text{ mA}$		4	30	mV
$\Delta V_O$	Load regulation	$V_I = 5.5\text{ V}$ , $I_O = 0.5\text{ to }100\text{ mA}$		3	25	mV
$I_d$	Quiescent current	$V_I = 5.5\text{ to }18\text{ V}$ , $I_O = 0\text{ mA}$	ON mode	0.5	1	mA
		$V_I = 5.5\text{ to }18\text{ V}$ , $I_O = 100\text{ mA}$		1.5	3	
		$V_I = 6\text{ V}$	OFF mode	50	100	$\mu\text{A}$
SVR	Supply voltage rejection	$I_O = 5\text{ mA}$ , $V_I = 6.5 \pm 1\text{ V}$	$f = 120\text{ Hz}$		77	dB
			$f = 1\text{ kHz}$		72	
			$f = 10\text{ kHz}$		60	
eN	Output noise voltage	$B = 10\text{ Hz to }100\text{ kHz}$		50		$\mu\text{V}$
$V_d$	Dropout voltage	$I_O = 100\text{ mA}$		0.2	0.4	V
		$I_O = 100\text{ mA}$ , $T_J = -40\text{ to }125\text{ °C}$			0.5	
$V_{IL}$	Control input logic low	$T_J = -40\text{ to }125\text{ °C}$			0.8	V
$V_{IH}$	Control input logic high	$T_J = -40\text{ to }125\text{ °C}$	2			V
$I_I$	Control input current	$V_I = 6\text{ V}$ , $V_C = 6\text{ V}$		10		$\mu\text{A}$
$C_O$	Output bypass capacitance	$\text{ESR} = 0.1\text{ to }10\text{ }\Omega$ , $I_O = 0\text{ to }100\text{ mA}$	2	10		$\mu\text{F}$

Refer to test circuits,  $T_J = 25\text{ °C}$ ,  $C_I = 0.1\text{ }\mu\text{F}$ ,  $C_O = 2.2\text{ }\mu\text{F}$  unless otherwise specified.

**Table 8. LE50AB electrical characteristics**

Symbol	Parameter	Test conditions	Min.	Typ.	Max.	Unit
$V_O$	Output voltage	$I_O = 10\text{ mA}$ , $V_I = 7\text{ V}$	4.95	5	5.05	V
		$I_O = 10\text{ mA}$ , $V_I = 7\text{ V}$ , $T_J = -25\text{ to }85\text{ °C}$	4.9		5.1	
$V_I$	Operating input voltage	$I_O = 100\text{ mA}$			18	V
$I_O$	Output current limit		150	350	425	mA
$\Delta V_O$	Line regulation	$V_I = 5.7\text{ to }18\text{ V}$ , $I_O = 0.5\text{ mA}$		4	20	mV
$\Delta V_O$	Load regulation	$V_I = 6\text{ V}$ , $I_O = 0.5\text{ to }100\text{ mA}$		3	15	mV
$I_d$	Quiescent current	$V_I = 6\text{ to }18\text{ V}$ , $I_O = 0\text{ mA}$	ON mode	0.5	1	mA
		$V_I = 6\text{ to }18\text{ V}$ , $I_O = 100\text{ mA}$		1.5	3	
		$V_I = 6\text{ V}$	OFF mode	50	100	$\mu\text{A}$
SVR	Supply voltage rejection	$I_O = 5\text{ mA}$ , $V_I = 7 \pm 1\text{ V}$	$f = 120\text{ Hz}$	76		dB
			$f = 1\text{ kHz}$	71		
			$f = 10\text{ kHz}$	60		
eN	Output noise voltage	$B = 10\text{ Hz to }100\text{ kHz}$		50		$\mu\text{V}$
$V_d$	Dropout voltage	$I_O = 100\text{ mA}$		0.2	0.4	V
		$I_O = 100\text{ mA}$ , $T_J = -40\text{ to }125\text{ °C}$			0.5	
$V_{IL}$	Control input logic low	$T_J = -40\text{ to }125\text{ °C}$			0.8	V
$V_{IH}$	Control input logic high	$T_J = -40\text{ to }125\text{ °C}$	2			V
$I_I$	Control input current	$V_I = 6\text{ V}$ , $V_C = 6\text{ V}$		10		$\mu\text{A}$
$C_O$	Output bypass capacitance	$\text{ESR} = 0.1\text{ to }10\text{ }\Omega$ , $I_O = 0\text{ to }100\text{ mA}$	2	10		$\mu\text{F}$

Refer to test circuits,  $T_J = 25\text{ °C}$ ,  $C_I = 0.1\text{ }\mu\text{F}$ ,  $C_O = 2.2\text{ }\mu\text{F}$  unless otherwise specified.

**Table 9. LE50C electrical characteristics**

Symbol	Parameter	Test conditions	Min.	Typ.	Max.	Unit
$V_O$	Output voltage	$I_O = 10\text{ mA}$ , $V_I = 7\text{ V}$	4.9	5	5.1	V
		$I_O = 10\text{ mA}$ , $V_I = 7\text{ V}$ , $T_J = -25\text{ to }85\text{ °C}$	4.8		5.2	
$V_I$	Operating input voltage	$I_O = 100\text{ mA}$			18	V
$I_O$	Output current limit		150	350	425	mA
$\Delta V_O$	Line regulation	$V_I = 5.7\text{ to }18\text{ V}$ , $I_O = 0.5\text{ mA}$		4	30	mV
$\Delta V_O$	Load regulation	$V_I = 6\text{ V}$ , $I_O = 0.5\text{ to }100\text{ mA}$		3	25	mV
$I_d$	Quiescent current	$V_I = 6\text{ to }18\text{ V}$ , $I_O = 0\text{ mA}$	ON mode	0.5	1	mA
		$V_I = 6\text{ to }18\text{ V}$ , $I_O = 100\text{ mA}$		1.5	3	
		$V_I = 6\text{ V}$	OFF mode	50	100	$\mu\text{A}$
SVR	Supply voltage rejection	$I_O = 5\text{ mA}$ , $V_I = 7 \pm 1\text{ V}$	$f = 120\text{ Hz}$	76		dB
			$f = 1\text{ kHz}$	71		
			$f = 10\text{ kHz}$	60		
eN	Output noise voltage	$B = 10\text{ Hz to }100\text{ kHz}$		50		$\mu\text{V}$
$V_d$	Dropout voltage	$I_O = 100\text{ mA}$		0.2	0.4	V
		$I_O = 100\text{ mA}$ , $T_J = -40\text{ to }125\text{ °C}$			0.5	
$V_{IL}$	Control input logic low	$T_J = -40\text{ to }125\text{ °C}$			0.8	V
$V_{IH}$	Control input logic high	$T_J = -40\text{ to }125\text{ °C}$	2			V
$I_I$	Control input current	$V_I = 6\text{ V}$ , $V_C = 6\text{ V}$		10		$\mu\text{A}$
$C_O$	Output bypass capacitance	$\text{ESR} = 0.1\text{ to }10\text{ }\Omega$ , $I_O = 0\text{ to }100\text{ mA}$	2	10		$\mu\text{F}$

Refer to test circuits,  $T_J = 25\text{ °C}$ ,  $C_I = 0.1\text{ }\mu\text{F}$ ,  $C_O = 2.2\text{ }\mu\text{F}$  unless otherwise specified.

**Table 10. LE80C electrical characteristics**

Symbol	Parameter	Test conditions	Min.	Typ.	Max.	Unit
$V_O$	Output voltage	$I_O = 10\text{ mA}$ , $V_I = 10\text{ V}$	7.84	8	8.16	V
		$I_O = 10\text{ mA}$ , $V_I = 10\text{ V}$ , $T_J = -25\text{ to }85\text{ °C}$	7.68		8.32	
$V_I$	Operating input voltage	$I_O = 100\text{ mA}$			18	V
$I_O$	Output current limit		150			mA
$\Delta V_O$	Line regulation	$V_I = 8.7\text{ to }18\text{ V}$ , $I_O = 0.5\text{ mA}$		5	35	mV
$\Delta V_O$	Load regulation	$V_I = 9\text{ V}$ , $I_O = 0.5\text{ to }100\text{ mA}$		3	25	mV
$I_d$	Quiescent current	$V_I = 9\text{ to }18\text{ V}$ , $I_O = 0\text{ mA}$	ON mode	0.7	1.6	mA
		$V_I = 9\text{ to }18\text{ V}$ , $I_O = 100\text{ mA}$		1.7	3.6	
		$V_I = 9\text{ V}$	OFF mode	70	140	$\mu\text{A}$
SVR	Supply voltage rejection	$I_O = 5\text{ mA}$ , $V_I = 10 \pm 1\text{ V}$	$f = 120\text{ Hz}$	72		dB
			$f = 1\text{ kHz}$	66		
			$f = 10\text{ kHz}$	57		
eN	Output noise voltage	$B = 10\text{ Hz to }100\text{ kHz}$		50		$\mu\text{V}$
$V_d$	Dropout voltage	$I_O = 100\text{ mA}$		0.2	0.4	V
		$I_O = 100\text{ mA}$ , $T_J = -40\text{ to }125\text{ °C}$			0.5	
$V_{IL}$	Control input logic low	$T_J = -40\text{ to }125\text{ °C}$			0.8	V
$V_{IH}$	Control input logic high	$T_J = -40\text{ to }125\text{ °C}$	2			V
$I_I$	Control input current	$V_I = 9\text{ V}$ , $V_C = 6\text{ V}$		10		$\mu\text{A}$
$C_O$	Output bypass capacitance	$\text{ESR} = 0.1\text{ to }10\text{ }\Omega$ , $I_O = 0\text{ to }100\text{ mA}$	2	10		$\mu\text{F}$

## 5 Typical performance characteristics

Unless otherwise specified,  $V_{O(NOM)} = 3.3\text{ V}$

**Figure 4. Dropout voltage vs. output current**

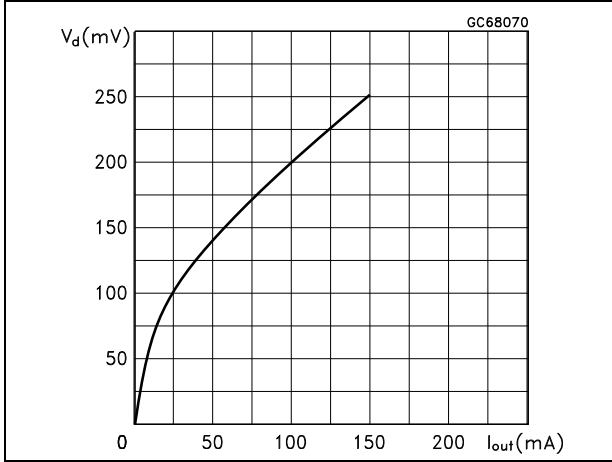

**Figure 5. Dropout voltage vs. temperature**

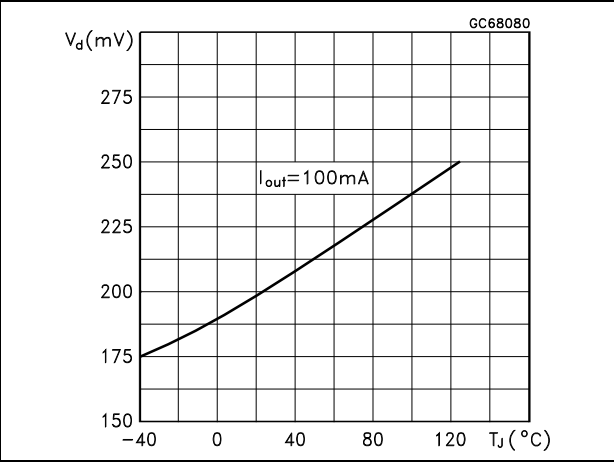

**Figure 6. Shutdown current vs. temperature**

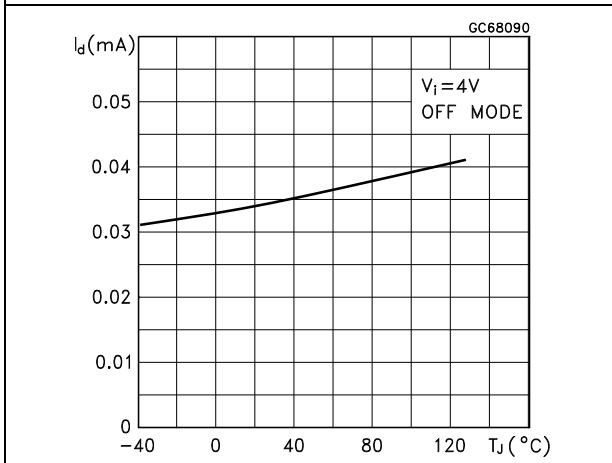

**Figure 7. Supply current vs. input voltage**

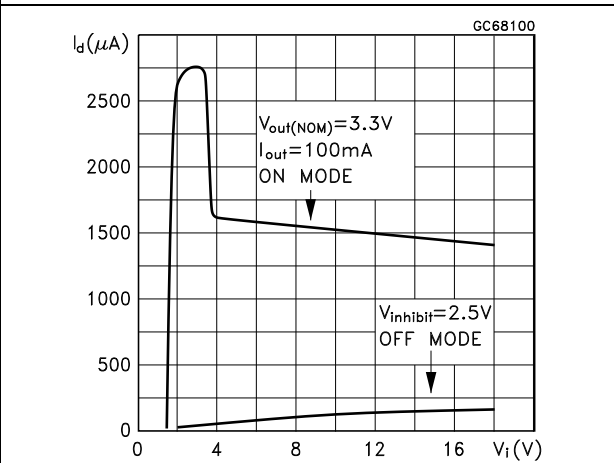

**Figure 8. Short-circuit current vs. dropout voltage**

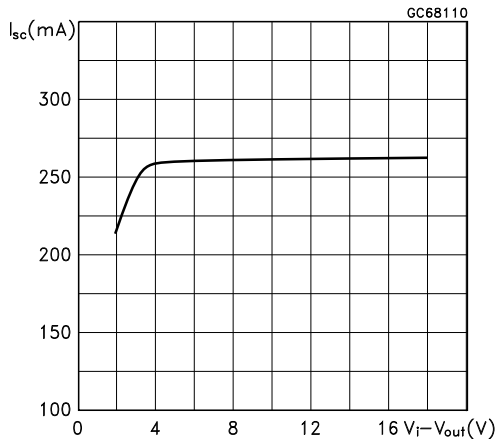

**Figure 9. SVR vs. frequency**

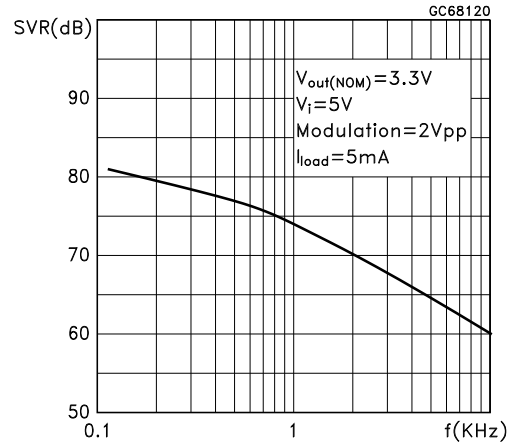

**Figure 10. Logic-controlled precision 3.3/5.0 V selectable output**

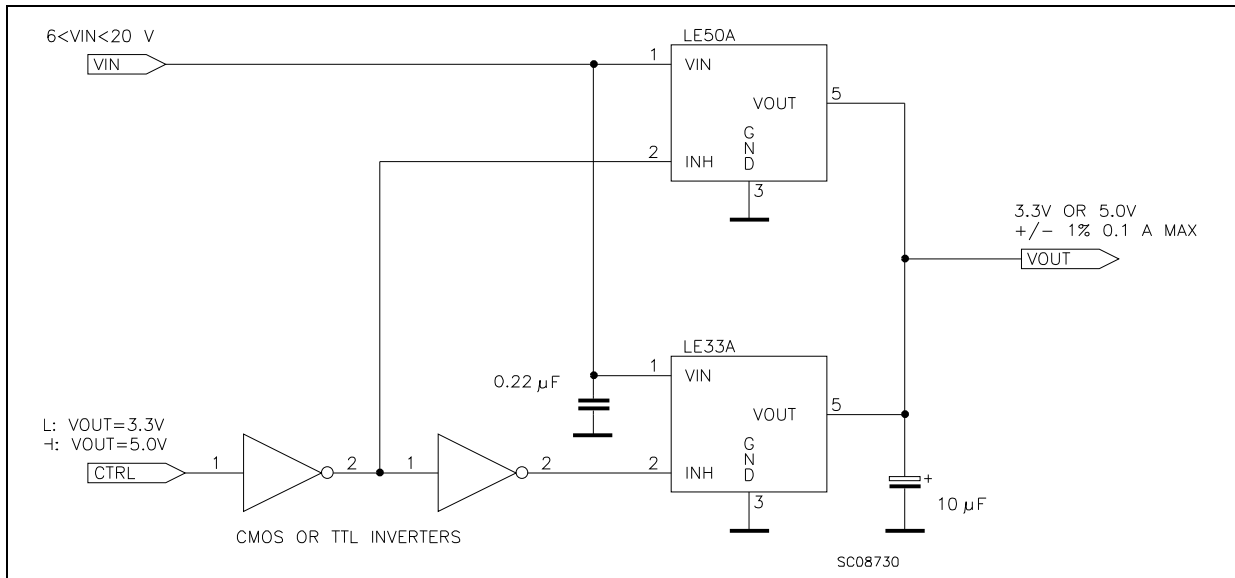

Figure 11. Sequential multi-output supply

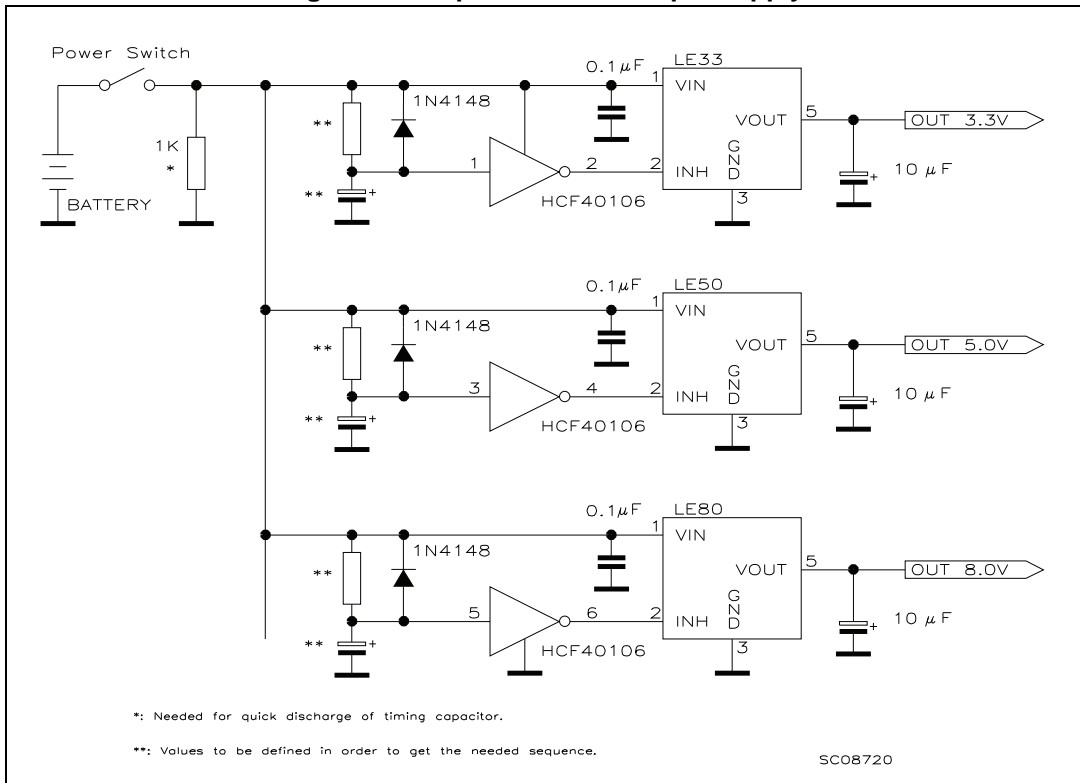
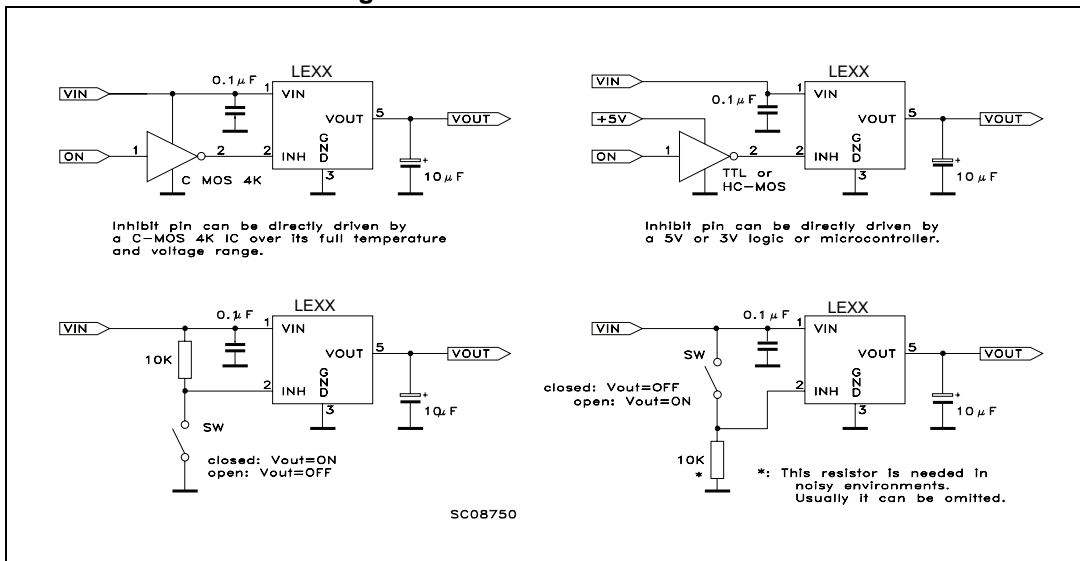

Figure 12. Basic inhibit functions





## 6 Package mechanical data

In order to meet environmental requirements, ST offers these devices in different grades of ECOPACK<sup>®</sup> packages, depending on their level of environmental compliance. ECOPACK<sup>®</sup> specifications, grade definitions and product status are available at: [www.st.com](http://www.st.com). ECOPACK<sup>®</sup> is an ST trademark.

Figure 13. SO-8 drawings

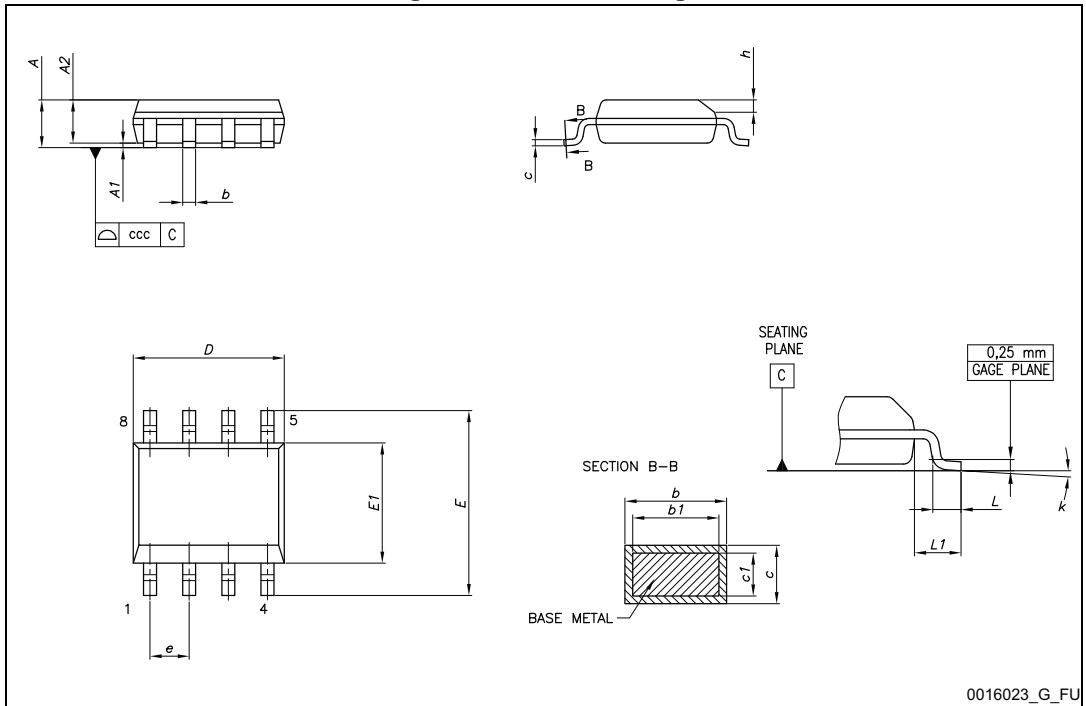

Table 11. SO-8 mechanical data

Dim.	mm		
	Min.	Typ.	Max.
A			1.75
A1	0.10		0.25
A2	1.25		
b	0.31		0.51
b1	0.28		0.48
c	0.10		0.25
c1	0.10		0.23
D	4.80	4.90	5.00
E	5.80	6.00	6.20
E1	3.80	3.90	4.00
e		1.27	
h	0.25		0.50
L	0.40		1.27
L1		1.04	
L2		0.25	
k	0°		8°
ccc			0.10

Figure 14. SO-8 recommended footprint

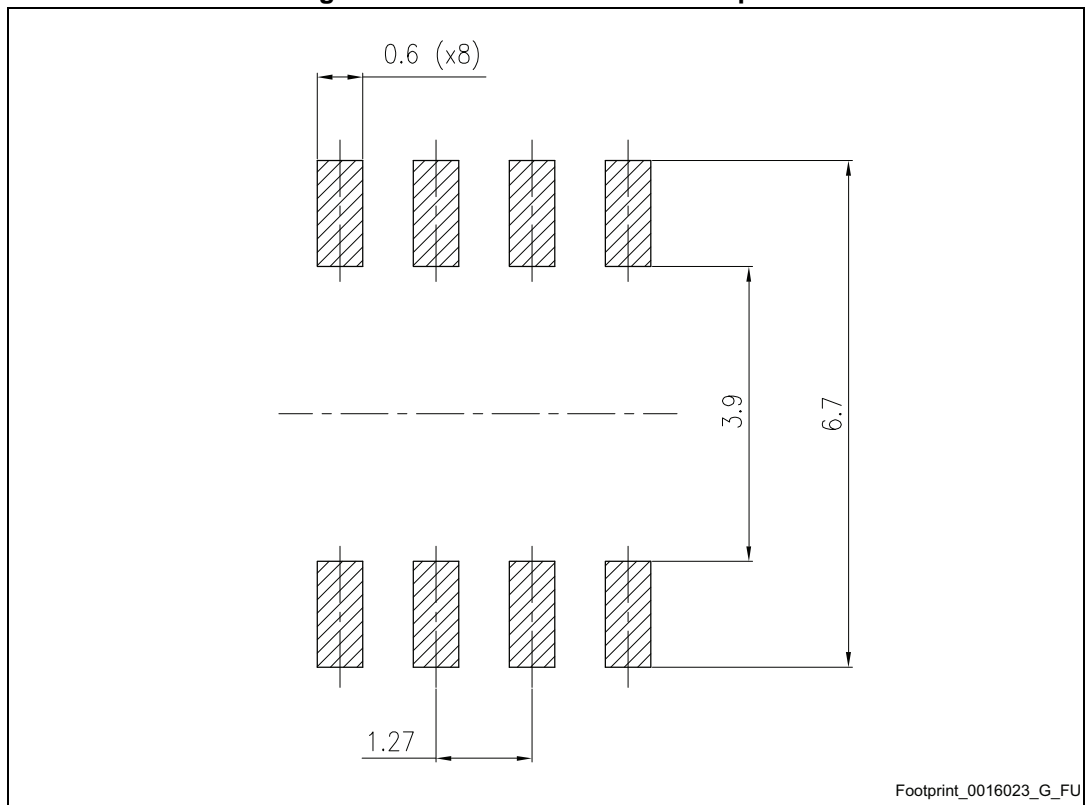

Figure 15. TO-92 bag drawings

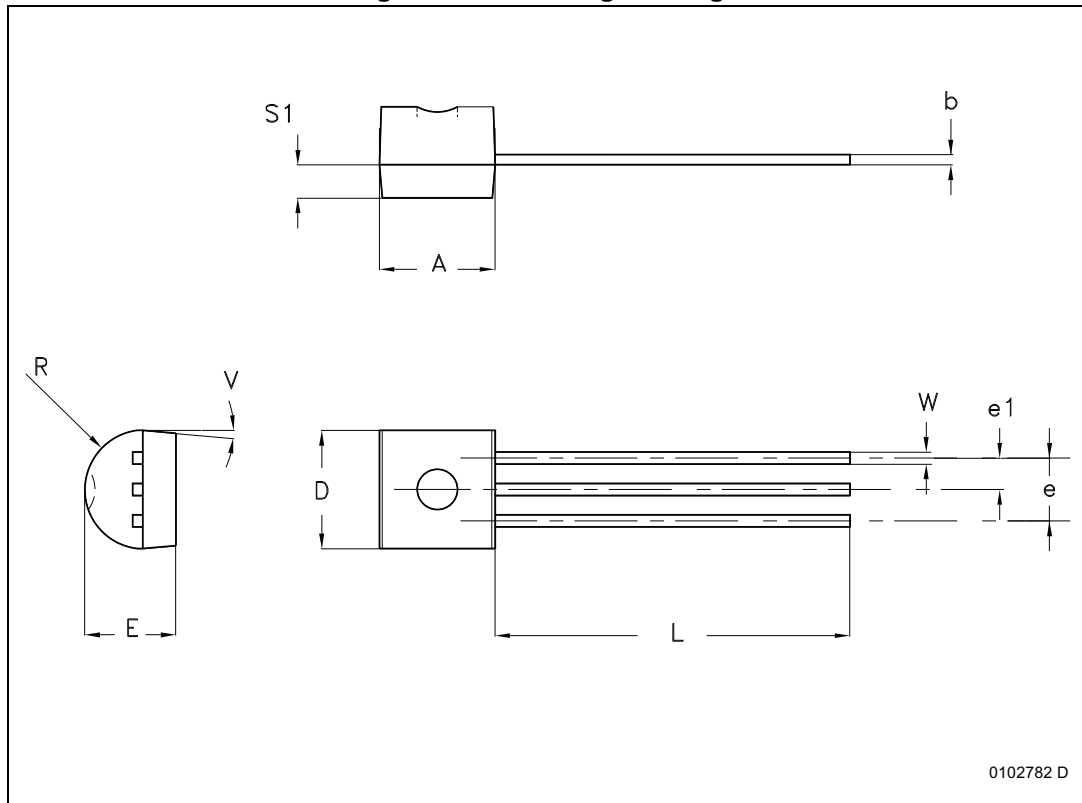

Table 12 TO-92 bag mechanical data

Dim.	mm		
	Min.	Typ.	Max.
A	4.32		4.95
b	0.36		0.51
D	4.45		4.95
E	3.30		3.94
e	2.41		2.67
e1	1.14		1.40
L	12.70		15.49
R	2.16		2.41
S1	0.92		1.52
W	0.41		0.56
V		5°	

# 7 Packaging information

Figure 16. SO-8 tape and reel drawings

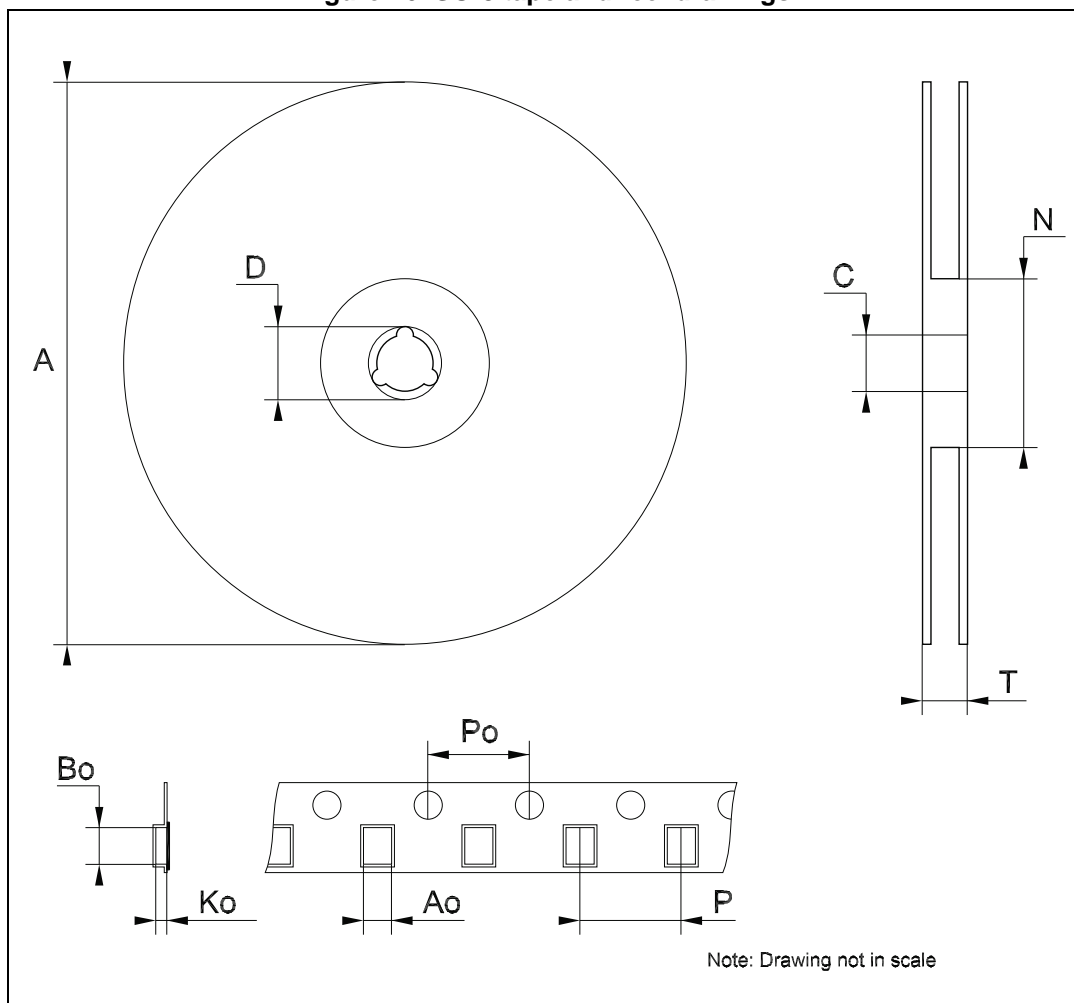

Table 13 SO-8 tape and reel mechanical data

Dim.	mm		
	Min.	Typ.	Max.
A			330
C	12.8		13.2
D	20.2		
N	60		
T			22.4
Ao	8.1		8.5
Bo	5.5		5.9
Ko	2.1		2.3
Po	3.9		4.1
P	7.9		8.1

Figure 17. TO-92 tape and reel drawings

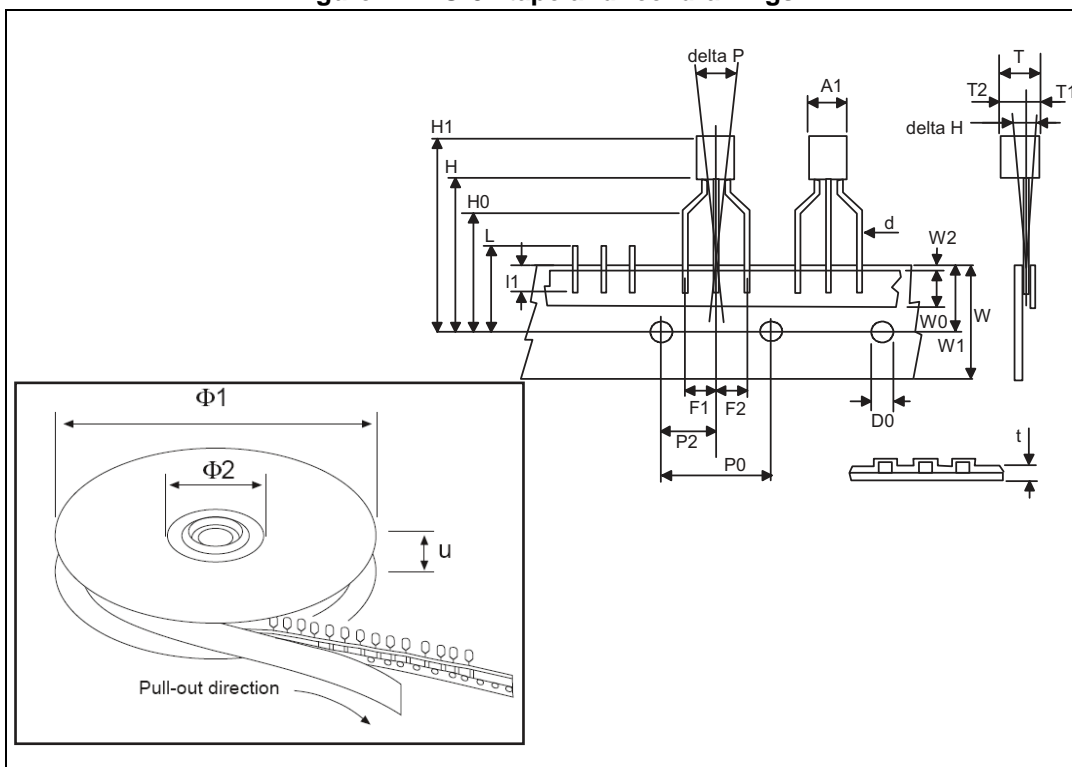

Table 14. TO-92 tape and reel mechanical data

Dim.	mm		
	Min.	Typ.	Max.
A1			4.80
T			3.80
T1			1.60
T2			2.30
d	0.45	0.47	0.48
P0	12.50	12.70	12.90
P2	5.65	6.35	7.05
F1, F2	2.40	2.50	2.94
F3	4.98	5.08	5.48
delta H	-2.00		2.00
W	17.50	18.00	19.00
W0	5.5	6.00	6.5
W1	8.50	9.00	9.25
W2			0.50
H		18.50	21
H3	0.5	1	2
H0	15.50	16.00	18.8
H1		25.0	27.0
D0	3.80	4.00	4.20
t			0.90
L			11.00
l1	3.00		
delta P	-1.00		1.00
Ø1	352	355	358
Ø2	28	30	32
u	44	47	50



Figure 18. TO-92 ammpack

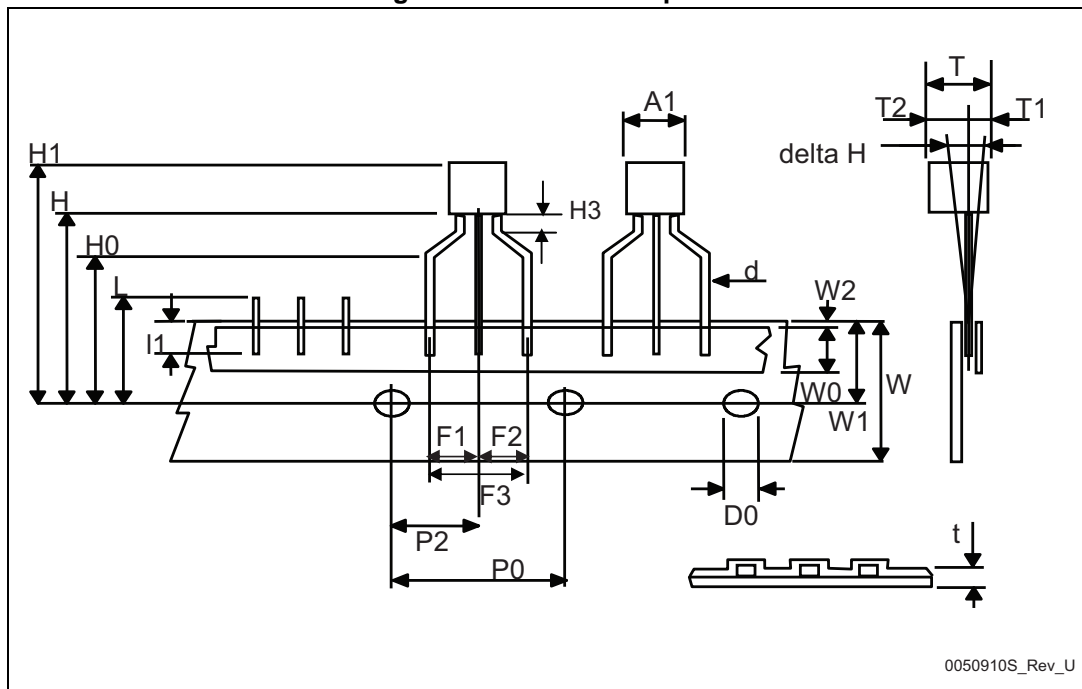

Table 15. TO-92 ammpack mechanical data

Dim.	mm		
	Min.	Typ.	Max.
A1			4.80
T			3.80
T1			1.60
T2			2.30
d	0.45	0.47	0.48
P0	12.50	12.70	12.90
P2	5.65	6.35	7.05
F1, F2	2.40	2.50	2.94
F3	4.98	5.08	5.48
delta H	-2.00		2.00
W	17.50	18.00	19.00
W0	5.5	6.00	6.5
W1	8.50	9.00	9.25
W2			0.50
H		18.50	21
H3	0.5	1	2
H0	15.50	16.00	18.8
H1		25.0	27.0
D0	3.80	4.00	4.20
t			0.90
L			11.00
l1	3.00		
delta P	-1.00		1.00

## 8 Revision history

**Table 16. Document revision history**

Date	Revision	Changes
09-Jul-2004	6	$I_O$ typ. and max. are changed in tab. 24 and 25 - pag. 14.
16-Mar-2005	7	Add Tape & Reel for TO-92 - Note on Table 3.
12-Feb-2007	8	Change value $T_{OP}$ on Table 2.
26-Jul-2007	9	Add Table 1 in cover page.
29-Nov-2007	10	Modified: Table 25.
12-Feb-2008	11	Modified: Table 25.
10-Jul-2008	12	Modified: Table 1 and Table 25.
22-May-2012	13	Updated: <a href="#">Table 1 on page 1</a> . Changed: $T_A$ in $T_J$ test conditions from table 4 to table 10.
14-Mar-2014	14	Changed the part numbers LExxAB and LExxC to LEXX. Updated the title. Added the ammopack package to the figure in cover page. Updated the <a href="#">Table 1: Device summary</a> . Updated the <a href="#">Description</a> . Updated <a href="#">Figure 3</a> . Changed the title of <a href="#">Figure 6</a> . Updated mechanical data.

**Please Read Carefully:**

Information in this document is provided solely in connection with ST products. STMicroelectronics NV and its subsidiaries ("ST") reserve the right to make changes, corrections, modifications or improvements, to this document, and the products and services described herein at any time, without notice.

All ST products are sold pursuant to ST's terms and conditions of sale.

Purchasers are solely responsible for the choice, selection and use of the ST products and services described herein, and ST assumes no liability whatsoever relating to the choice, selection or use of the ST products and services described herein.

No license, express or implied, by estoppel or otherwise, to any intellectual property rights is granted under this document. If any part of this document refers to any third party products or services it shall not be deemed a license grant by ST for the use of such third party products or services, or any intellectual property contained therein or considered as a warranty covering the use in any manner whatsoever of such third party products or services or any intellectual property contained therein.

**UNLESS OTHERWISE SET FORTH IN ST'S TERMS AND CONDITIONS OF SALE ST DISCLAIMS ANY EXPRESS OR IMPLIED WARRANTY WITH RESPECT TO THE USE AND/OR SALE OF ST PRODUCTS INCLUDING WITHOUT LIMITATION IMPLIED WARRANTIES OF MERCHANTABILITY, FITNESS FOR A PARTICULAR PURPOSE (AND THEIR EQUIVALENTS UNDER THE LAWS OF ANY JURISDICTION), OR INFRINGEMENT OF ANY PATENT, COPYRIGHT OR OTHER INTELLECTUAL PROPERTY RIGHT.**

**ST PRODUCTS ARE NOT DESIGNED OR AUTHORIZED FOR USE IN: (A) SAFETY CRITICAL APPLICATIONS SUCH AS LIFE SUPPORTING, ACTIVE IMPLANTED DEVICES OR SYSTEMS WITH PRODUCT FUNCTIONAL SAFETY REQUIREMENTS; (B) AERONAUTIC APPLICATIONS; (C) AUTOMOTIVE APPLICATIONS OR ENVIRONMENTS, AND/OR (D) AEROSPACE APPLICATIONS OR ENVIRONMENTS. WHERE ST PRODUCTS ARE NOT DESIGNED FOR SUCH USE, THE PURCHASER SHALL USE PRODUCTS AT PURCHASER'S SOLE RISK, EVEN IF ST HAS BEEN INFORMED IN WRITING OF SUCH USAGE, UNLESS A PRODUCT IS EXPRESSLY DESIGNATED BY ST AS BEING INTENDED FOR "AUTOMOTIVE, AUTOMOTIVE SAFETY OR MEDICAL" INDUSTRY DOMAINS ACCORDING TO ST PRODUCT DESIGN SPECIFICATIONS. PRODUCTS FORMALLY ESCC, QML OR JAN QUALIFIED ARE DEEMED SUITABLE FOR USE IN AEROSPACE BY THE CORRESPONDING GOVERNMENTAL AGENCY.**

Resale of ST products with provisions different from the statements and/or technical features set forth in this document shall immediately void any warranty granted by ST for the ST product or service described herein and shall not create or extend in any manner whatsoever, any liability of ST.

ST and the ST logo are trademarks or registered trademarks of ST in various countries.

Information in this document supersedes and replaces all information previously supplied.

The ST logo is a registered trademark of STMicroelectronics. All other names are the property of their respective owners.

© 2014 STMicroelectronics - All rights reserved

STMicroelectronics group of companies

Australia - Belgium - Brazil - Canada - China - Czech Republic - Finland - France - Germany - Hong Kong - India - Israel - Italy - Japan - Malaysia - Malta - Morocco - Philippines - Singapore - Spain - Sweden - Switzerland - United Kingdom - United States of America

[www.st.com](http://www.st.com)

