



**HESTORE.HU**

elektronikai alkatrész áruház

**EN:** This Datasheet is presented by the manufacturer.

Please visit our website for pricing and availability at [www.hestore.hu](http://www.hestore.hu).

## ULN2003/ULN2004 Seven Darlington array

### Features

- Seven Darlington pairs per package
- Output current 500 mA per driver (600 mA peak)
- Output voltage 50 V
- Integrated suppression diodes for inductive loads
- Outputs can be paralleled for higher current
- TTL/CMOS/PMOS/DTL compatible inputs
- Inputs pinned opposite outputs to simplify layout

### Description

The ULN2003, ULN2004, are high voltage, high current Darlington arrays each containing seven open collector Darlington pairs with common emitters. Each channel rated at 500 mA and can withstand peak currents of 600 mA. Suppression diodes are included for inductive load driving and the inputs are pinned opposite the outputs to simplify board layout.

The versions interface to all common logic families:

- ULN2003 (5 V TTL, CMOS)
- ULN2004 (6 - 15 V CMOS, PMOS)

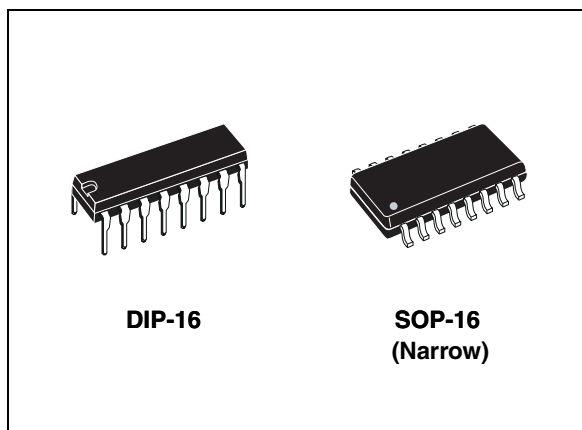

These versatile devices are useful for driving a wide range of loads including solenoids, relays DC motors, LED displays filament lamps, thermal printheads and high power buffers.

The ULN2003A/2004A are supplied in 16 pin plastic DIP packages with a copper leadframe to reduce thermal resistance. They are available also in small outline package (SOP-16) as ULN2003D/2004D

### Pin configuration

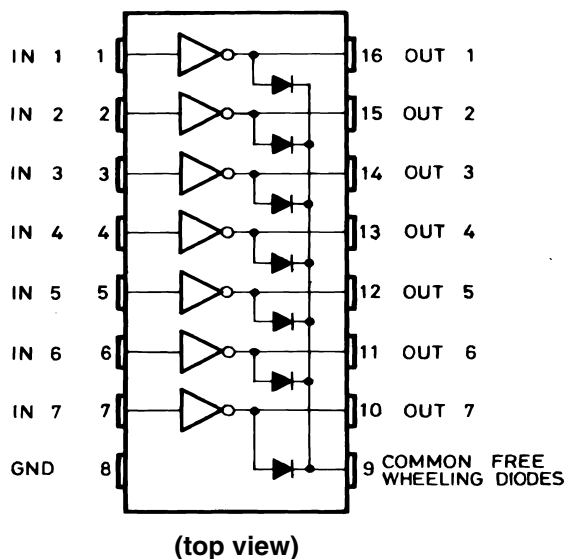

# Diagram

Schematic diagram

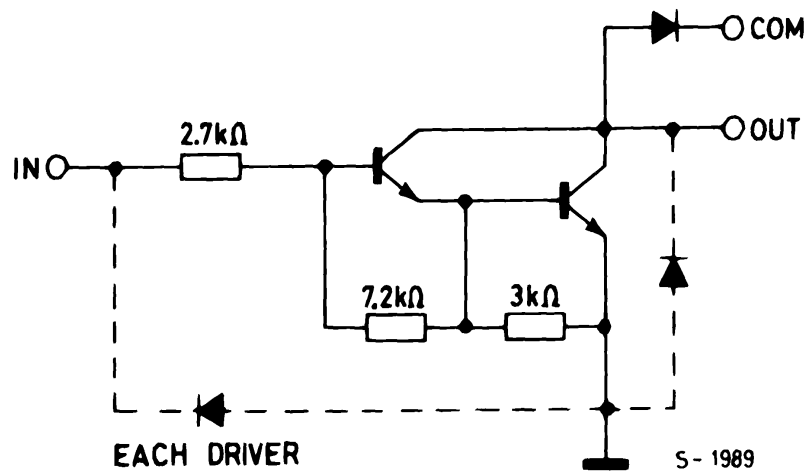

ULN2003 (each driver)

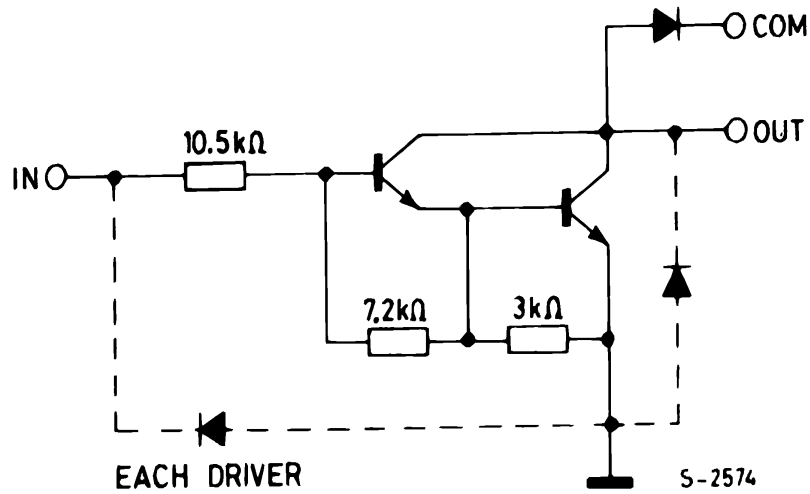

ULN2004 (each driver)

## Maximum ratings

### Absolute maximum ratings

Symbol	Parameter	Value	Unit
$V_O$	Output voltage	50	V
$V_I$	Input voltage (for ULN2003A/D - 2004A/D )	30	V
$I_C$	Continuous collector current	500	mA
$I_B$	Continuous base current	25	mA
$T_A$	Operating ambient temperature range	- 40 to 85	°C
$T_{STG}$	Storage temperature range	- 55 to 150	°C
$T_J$	Junction temperature	150	°C

### Thermal data

Symbol	Parameter	DIP-16	SO-16	Unit
$R_{thJA}$	Thermal resistance junction-ambient, Max.	70	120	°C/W

## Electrical characteristics

$T_A = 25\text{ }^\circ\text{C}$  unless otherwise specified.

### Electrical characteristics

Symbol	Parameter	Test condition	Min.	Typ.	Max.	Unit
$I_{CEX}$	Output leakage current	$V_{CE} = 50\text{ V}$ , ( <i>Figure 1.</i> )			50	$\mu\text{A}$
		$T_A = 85\text{ }^\circ\text{C}$ , $V_{CE} = 50\text{ V}$ ( <i>Figure 1.</i> )			100	
		$T_A = 85\text{ }^\circ\text{C}$ for ULN2002, $V_{CE} = 50\text{ V}$ , $V_I = 6\text{ V}$ ( <i>Figure 2.</i> )			500	
		$T_A = 85\text{ }^\circ\text{C}$ for ULN2002, $V_{CE} = 50\text{ V}$ , $V_I = 1\text{ V}$ ( <i>Figure 2.</i> )			500	
$V_{CE(SAT)}$	Collector-emitter saturation voltage ( <i>Figure 3.</i> )	$I_C = 100\text{ mA}$ , $I_B = 250\text{ }\mu\text{A}$		0.9	1.1	V
		$I_C = 200\text{ mA}$ , $I_B = 350\text{ }\mu\text{A}$		1.1	1.3	
		$I_C = 350\text{ mA}$ , $I_B = 500\text{ }\mu\text{A}$		1.3	1.6	
$I_{I(ON)}$	Input current ( <i>Figure 4.</i> )	for ULN2002, $V_I = 17\text{ V}$		0.82	1.25	mA
		for ULN2003, $V_I = 3.85\text{ V}$		0.93	1.35	
		for ULN2004, $V_I = 5\text{ V}$		0.35	0.5	
		$V_I = 12\text{ V}$		1	1.45	
$I_{I(OFF)}$	Input current ( <i>Figure 5.</i> )	$T_A = 85\text{ }^\circ\text{C}$ , $I_C = 500\text{ }\mu\text{A}$	50	65		$\mu\text{A}$
$V_{I(ON)}$	Input voltage ( <i>Figure 6.</i> )	$V_{CE} = 2\text{ V}$ , for ULN2002			13	V
		$I_C = 300\text{ mA}$			2.4	
		for ULN2003			2.7	
		$I_C = 200\text{ mA}$			3	
		$I_C = 250\text{ mA}$			5	
		for ULN2004			6	
		$I_C = 125\text{ mA}$			7	
		$I_C = 200\text{ mA}$			8	
$I_C = 275\text{ mA}$						
$I_C = 350\text{ mA}$						
$h_{FE}$	DC Forward current gain ( <i>Figure 3.</i> )	for ULN2001, $V_{CE} = 2\text{ V}$ , $I_C = 350\text{ mA}$	1000			
$C_I$	Input capacitance			15	25	pF
$t_{PLH}$	Turn-on delay time	$0.5 V_I$ to $0.5 V_O$		0.25	1	$\mu\text{s}$
$t_{PHL}$	Turn-off delay time	$0.5 V_I$ to $0.5 V_O$		0.25	1	$\mu\text{s}$
$I_R$	Clamp diode leakage current ( <i>Figure 7.</i> )	$V_R = 50\text{ V}$			50	$\mu\text{A}$
		$T_A = 85\text{ }^\circ\text{C}$ , $V_R = 50\text{ V}$			100	
$V_F$	Clamp diode forward voltage ( <i>Figure 8.</i> )	$I_F = 350\text{ mA}$		1.7	2	V

## Test circuits

Figure 1. Output leakage current

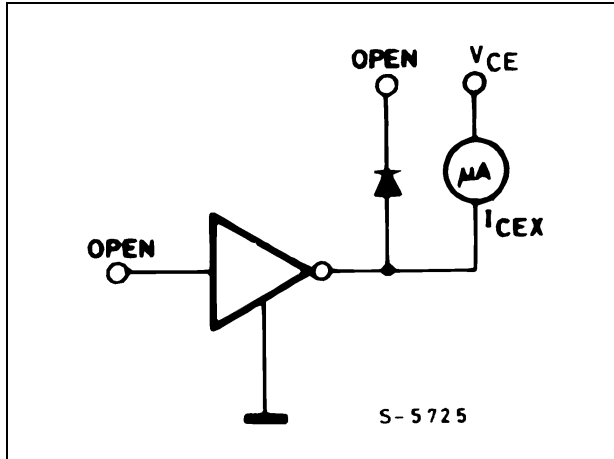

Figure 2. Output leakage current

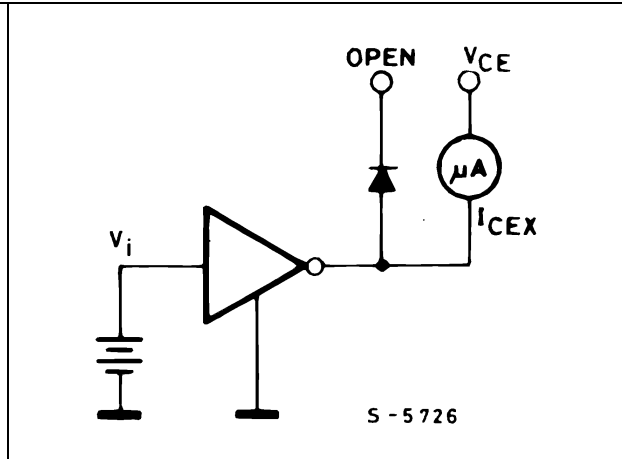

Figure 3. Collector-emitter saturation voltage

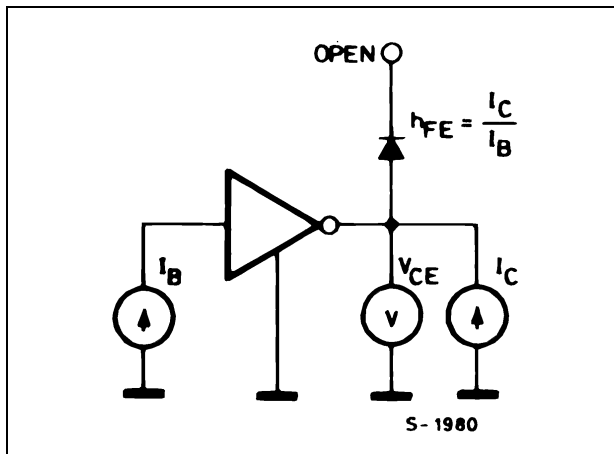

Figure 4. Input current (ON)

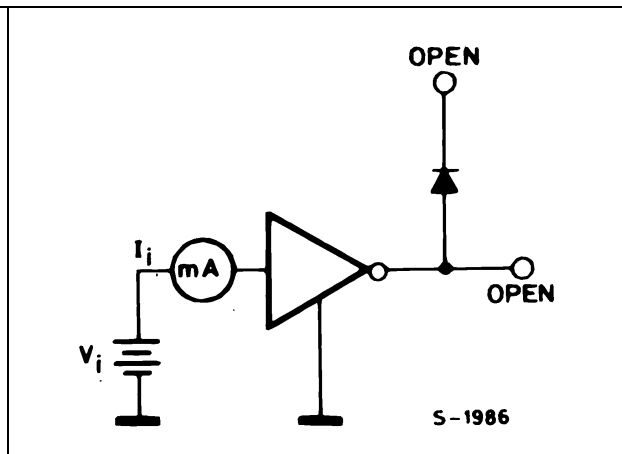

Figure 5. Input current (OFF)

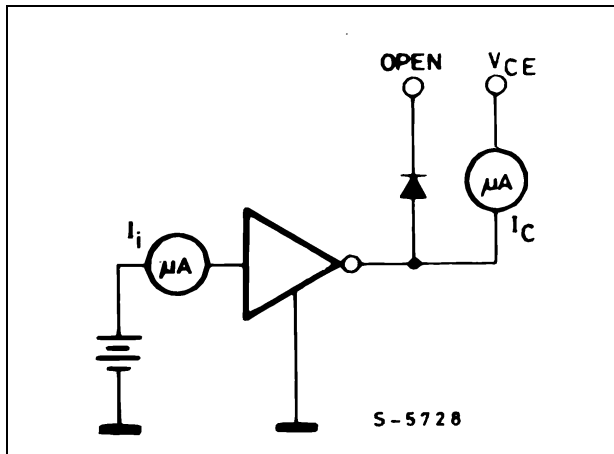

Figure 6. Input voltage

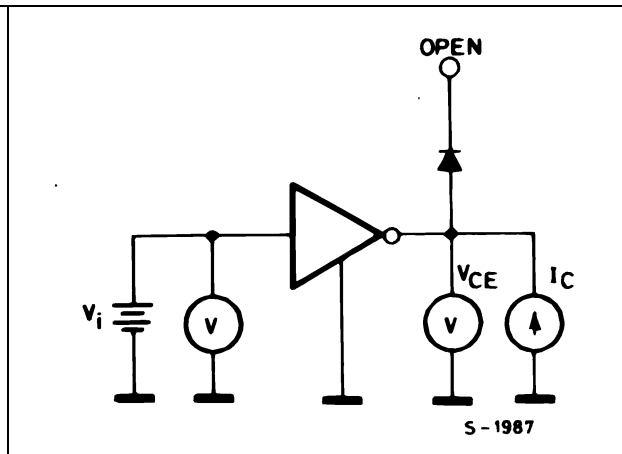

Figure 7. Clamp diode leakage current

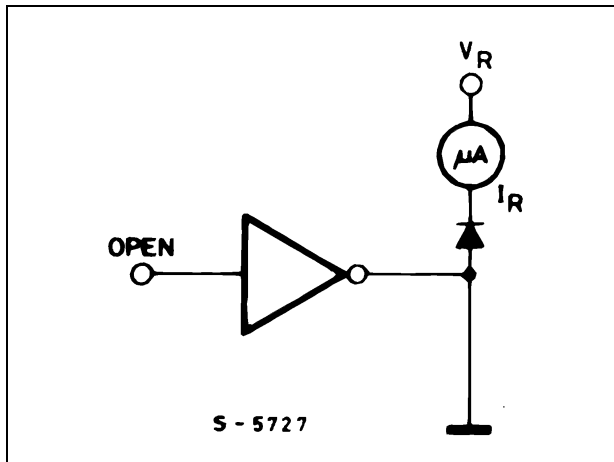
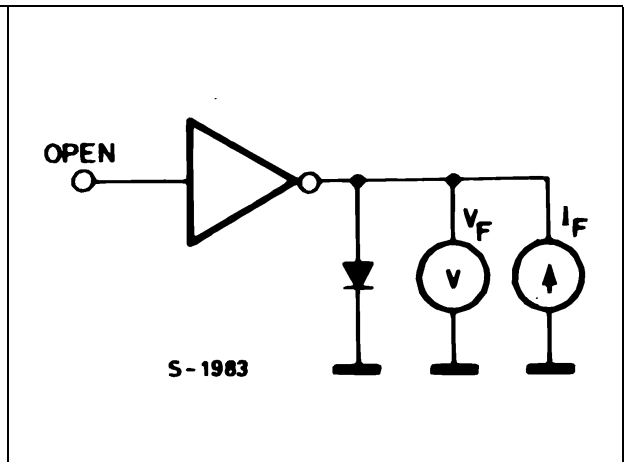

Figure 8. Clamp diode forward voltage



## Typical performance characteristics

Figure 9. Collector current vs. saturation voltage ( $T_J = 25^\circ\text{C}$ )

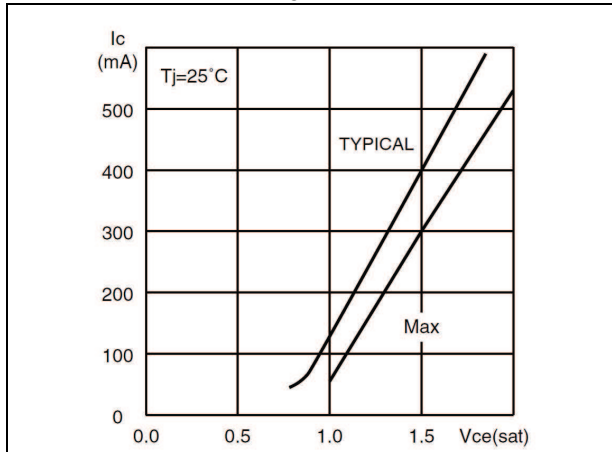

Figure 10. Collector current vs. saturation voltage

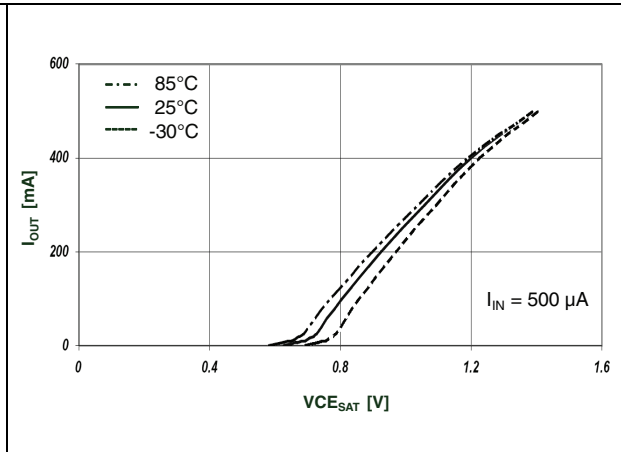

Figure 11. Input current vs. input voltage

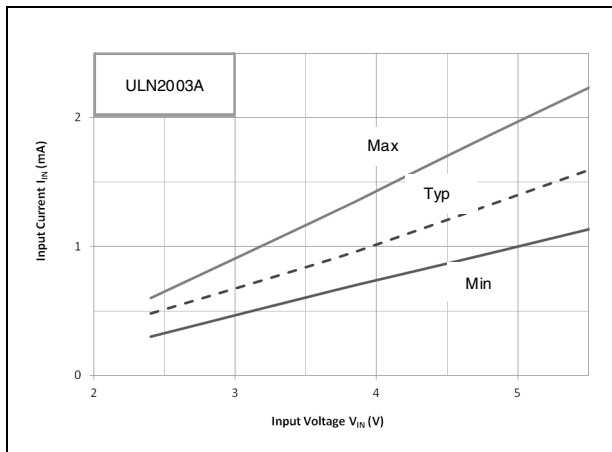

Figure 12. Input current vs. input voltage ( $T_a = 25^\circ\text{C}$ )

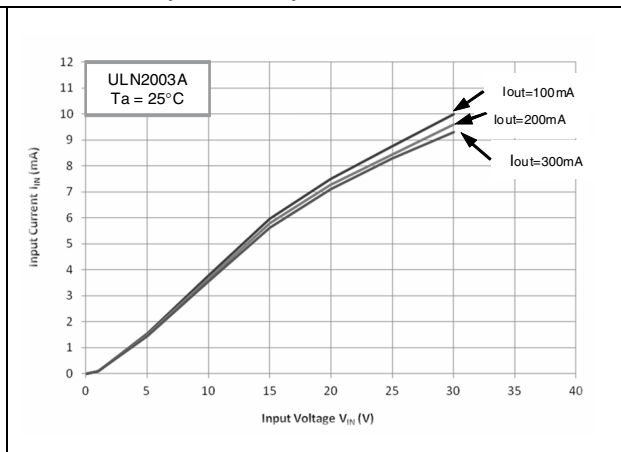

Figure 13. Collector current vs. input current

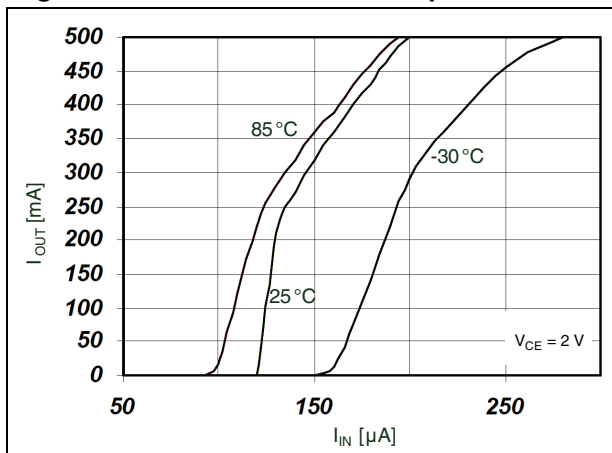

Figure 14.  $h_{FE}$  vs. output current

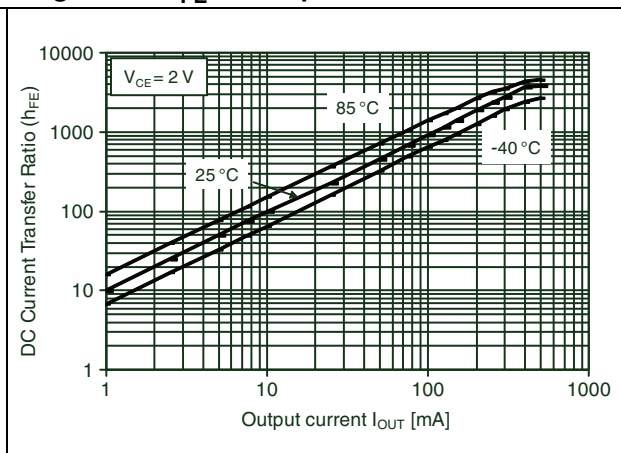



Figure 15. Peak collector current vs. duty cycle (DIP-16)

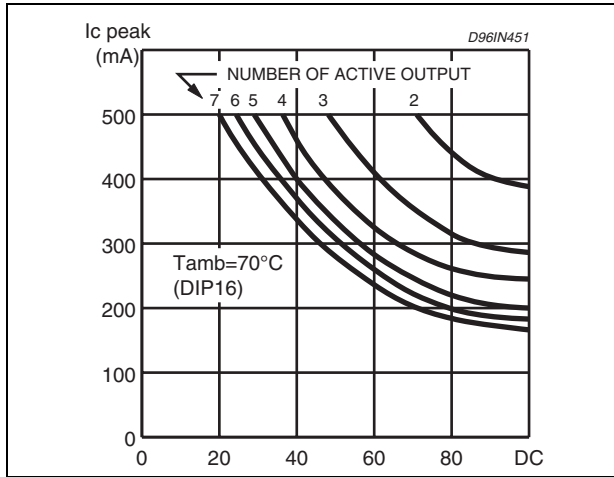

Figure 16. Peak collector current vs. duty cycle (SO-16)

