



HESTORE.HU

elektronikai alkatrész áruház

EN: This Datasheet is presented by the manufacturer.

Please visit our website for pricing and availability at www.hestore.hu.



Digital Pyroelectric Infrared Sensor (Model: RDB226S)

User's Manual

Version: 1.3

Valid from: 2022-05-20

Zhengzhou Winsen Electronics Technology Co., Ltd

Statement

This manual copyright belongs to Zhengzhou Winsen Electronics Technology Co., LTD. Without the written permission, any part of this manual shall not be copied, translated, stored in database or retrieval system, also can't spread through electronic, copying, record ways.

Thanks for purchasing our product. In order to let customers use it better and reduce the faults caused by misuse, please read the manual carefully and operate it correctly in accordance with the instructions. If users disobey the terms or remove, disassemble, change the components inside of the sensor, we shall not be responsible for the loss.

The specific such as color, appearance, sizes &etc, please in kind prevail.

We are devoting ourselves to products development and technical innovation, so we reserve the right to improve the products without notice. Please confirm it is the valid version before using this manual. At the same time, users' comments on optimized using way are welcome.

Please keep the manual properly, in order to get help if you have questions during the usage in the future.

Zhengzhou Winsen Electronics Technology CO., LTD.

RDB226S Digital Pyroelectric Infrared Sensor

Digital PIR sensor RDB226S, is an integrated design of sensitive element and signal processing chip, packaged sensitive element and IC chip into sensor shield. Sensitive element transfer the human movement signal to high-precision digital chip for data processing. Then the sensor gives digital signal for easy using.

Features:

- * High-precision AD signal process
- * Differential signal input mode, anti-interference ability
- * Sensitivity, delay time, and light adjustment function
- * Enable pin controls the sensor output
- * Wide voltage power supply(1.8~4.5V) and power consumption
- * Digital TTL signal output



Applications

Security product
 Human body induction toys
 Human body induction lamps, and switches
 Industrial automation control
 Smart home
 IOT terminals
 Intelligent appliance

Technical Parameter

1. Working condition(T=25°C)

Parameter	Symbol	Min	Typical	Max	Unit	Note
Working condition						
Voltage	VDD	1.8	3.0	4.5	V	Power supply mode
Current	IDD		10		uA	10uA @3V@25°C
Sensitivity	VSENS	104		515	uV	
Storage temperature	Tst	-40		125	°C	
Working Temperature	Twk	-25		85	°C	
ONTIME&SENS&OEN						
SENS, ONTIME Input		0		VDD		
SENS, ONTIME Input Current				20	nA	Pull-down current
OEN Input Low LEL	V _{IL_OEN}			0.6	V	
OEN Input High LEL	V _{IH_OEN}	1.2			V	
Output Pin(REL)						
Output drive current	I _{REL}	-5		5	mA	
Block time		1.0	2.0	3.0	S	
Delay time	ON _{TIME}	1		3600	S	16 levels of adjustment

2. Internal frame

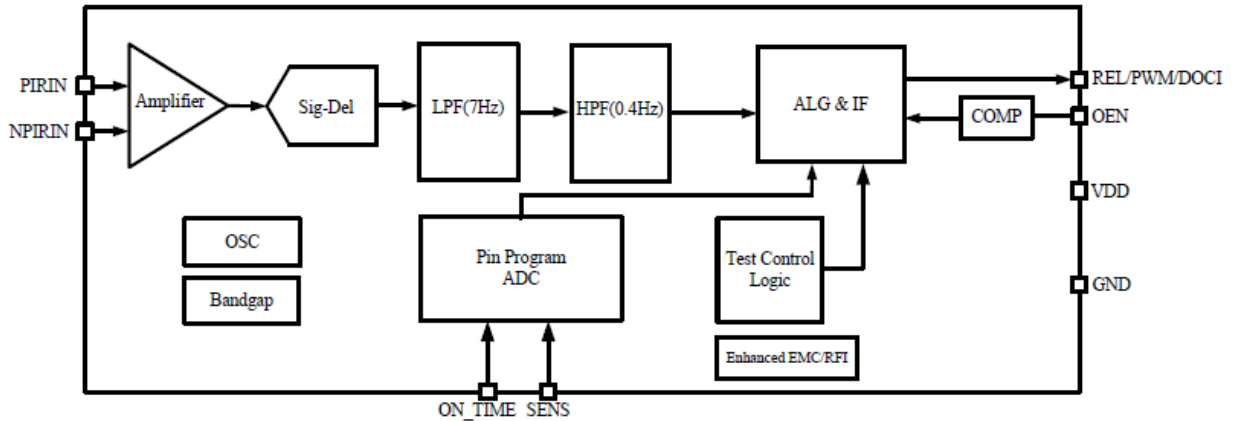

3. Trigger mode

In the normal detection condition, the following two conditions are valid:

- (1) When the signal amplitude successively exceeds the positive and negative thresholds within 4S ;
- (2) The signal amplitude exceeds 5 times the threshold;

After the sensor is effectively triggered, the REL pin gives output and maintains a high level for a certain period of time. The output high level time can be adjusted by the voltage divider resistor of the ONTIME pin. During the high level output period, if the effective trigger signal is detected again, the output high time is recalculated.

Remark: The sensor has warm-up time. After power on, the REL pin outputs high level for 10 seconds and low level for 2 seconds. Warm-up time has nothing to do with ONTIME

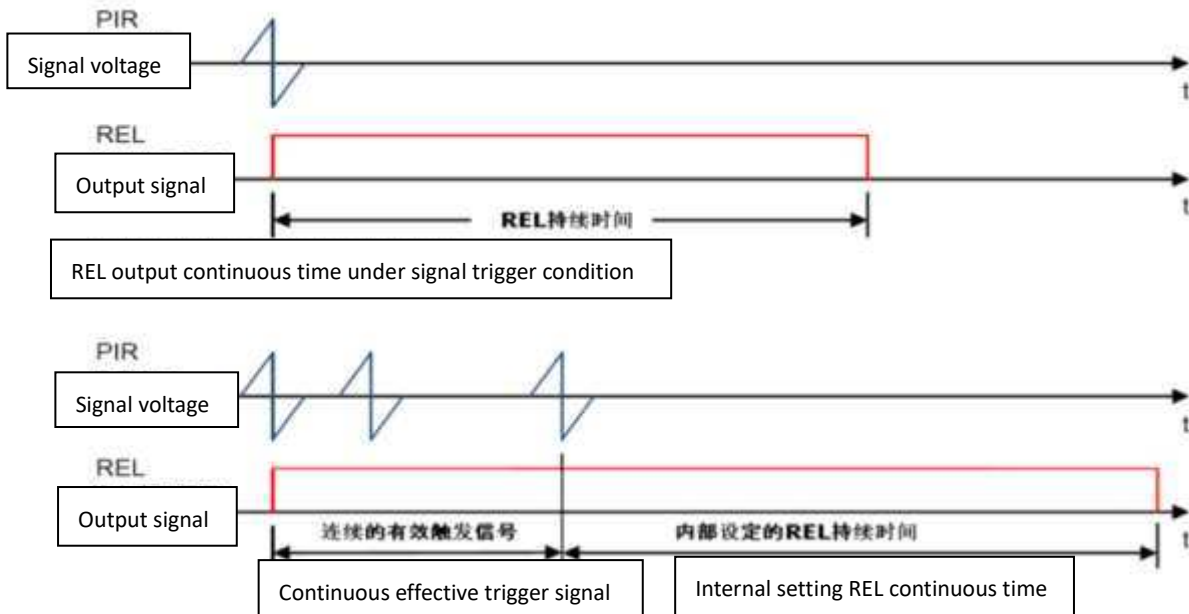

4. Delay time adjustment

The delay time is the high-level TTL output duration time when sensor reaches the comparison threshold. The input voltage of ONTIME pin, determines the duration of output signal. Each time a trigger signal is received, the delay time is recalculated.

Relationship between ONTIME pin voltage, delay time and voltage divider resistance:

Item	Corresponding pin voltage range	Center value of Pin voltage	Duration time (Second)	Pull-up resistor (ohm)	Theoretical pull-down resistor(ohm)	Recommended pull-down resistor(ohm)
1	(0~8/256) *VDD	1*VDD/64	1	1M	16k	GND
2	(9/256~16/256) *VDD	3*VDD/64	5	1M	49k	47k
3	(17/256~24/256) *VDD	5*VDD/64	10	1M	85k	82k
4	(25/256~32/256) *VDD	7*VDD/64	15	1M	122k	120k
5	(33/256~40/256) *VDD	9*VDD/64	20	1M	164k	160k
6	(41/256~48/256) *VDD	11*VDD/64	30	1M	208k	205k
7	(49/256~56/256) *VDD	13*VDD/64	45	1M	255k	261k
8	(57/256~64/256) *VDD	15*VDD/64	60	1M	306k	300k
9	(65/256~72/256) *VDD	17*VDD/64	90	1M	362k	360k
10	(73/256~80/256) *VDD	19*VDD/64	120	1M	422k	430k
11	(81/256~88/256) *VDD	21*VDD/64	180	1M	488k	487k
12	(89/256~96/256) *VDD	23*VDD/64	300	1M	561k	560k
13	(97/256~104/256) *VDD	25*VDD/64	600	1M	641k	620k
14	(105/256~112/256) *VDD	27*VDD/64	900	1M	730k	750k
15	(113/256~120/256) *VDD	29*VDD/64	1800	1M	829k	820k
16	(121/256~128/256) *VDD	31*VDD/64	3600	1M	940k	1M

5. Sensitivity adjustment

The SENS pin sets comparison threshold of different signals, by setting different voltages through an external resistor network.

When connected to ground, the sensor comparison threshold is the lowest, sensitivity is highest, that is, detection distance is the farthest.

When the input voltage is over 1/2VDD, it would choose max threshold, sensitivity is the lowest, that is, the detection distance is minimal.

The sensing distance is not linear with the voltage on the SENS pin. With different Fresnel lenses, the sensitivity is different, and distance depends on actual measurement.

Relationship between sensitivity threshold and resistance network:

Sensitivity threshold	Pull-up resistor ohm	Pull-down resistor ohm
-----------------------	----------------------	------------------------

104uv	1M	GND
141uv	1M	47k
186uv	1M	110k
230uv	1M	180k
264uv	1M	240k
309uv	1M	330k
368uv	1M	470k
400uv	1M	560k
438uv	1M	680k
515uv	1M	1M

The relationship between SENS pin voltage and threshold

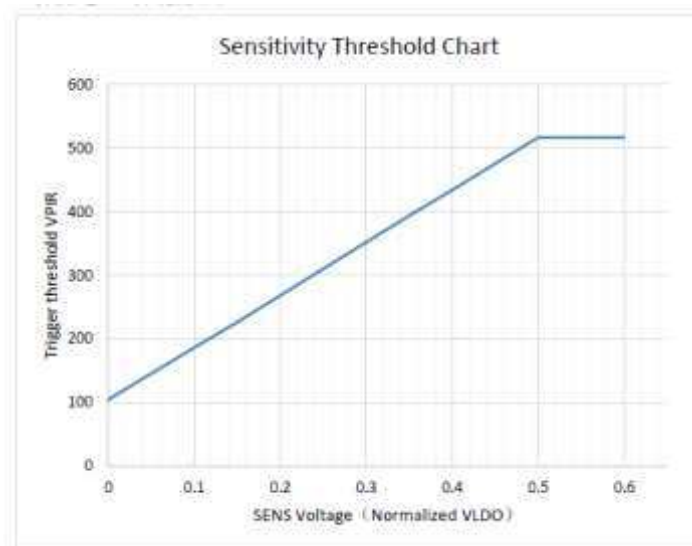

Sensor Detection Angle

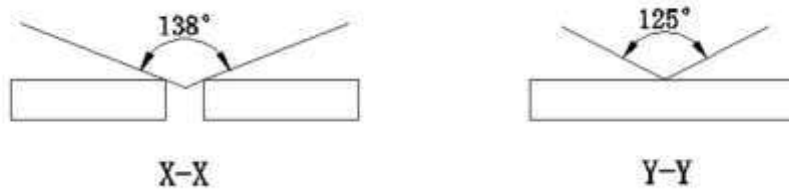

Component Structure (Unit: mm)

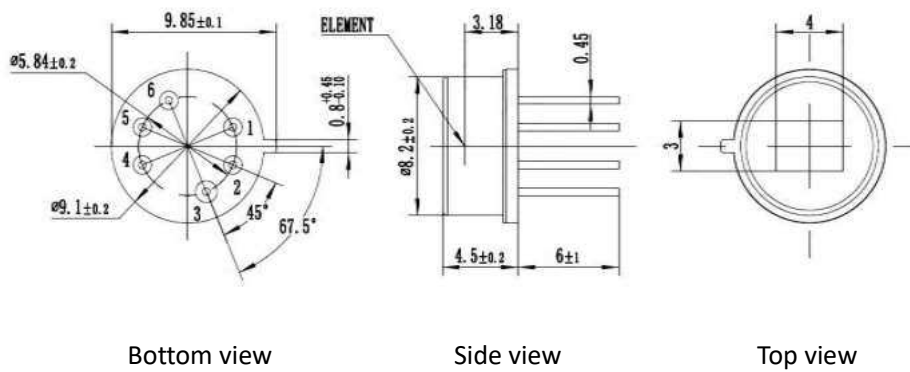

Pin Definition

Item	Name	Definition
1	SENS	Sensitivity pin (0-1/2V _{DD}); 0- highest sensitivity; $\geq 1/2V_{DD}$ - Lowest sensitivity
2	OEN	photo-cell adjustment pin, OEN PIN (20% V _{DD} ~80%V _{DD})
3	VSS	power ground
4	VDD	sensor power supply pin
5	REL	sensor output pin, TTL high/low level output
6	ONTime	delay time adjustment pin, 16 level option, the delay time is recalculated after each trigger
Note		Select 0, it's recommended using a resistor to pull down to ground. Select high level, it's recommended pulling up to high level with resistor.

Frequency characteristic

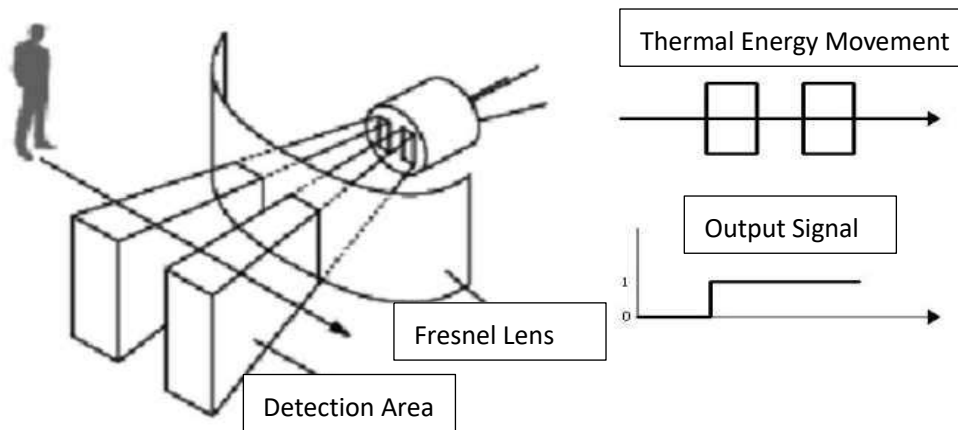

Fresnel Lens:

Fresnel Lens used, would determine the sensor's detection angle and distance, which can correspond to a variety of detection range and distance, according to customers' requirement.

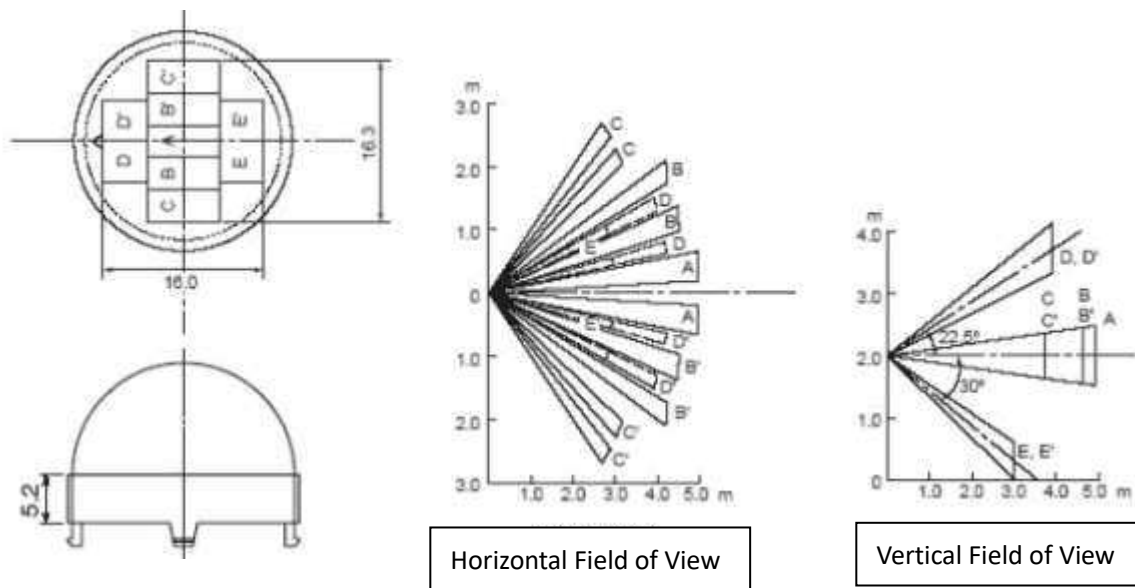

Wave Length

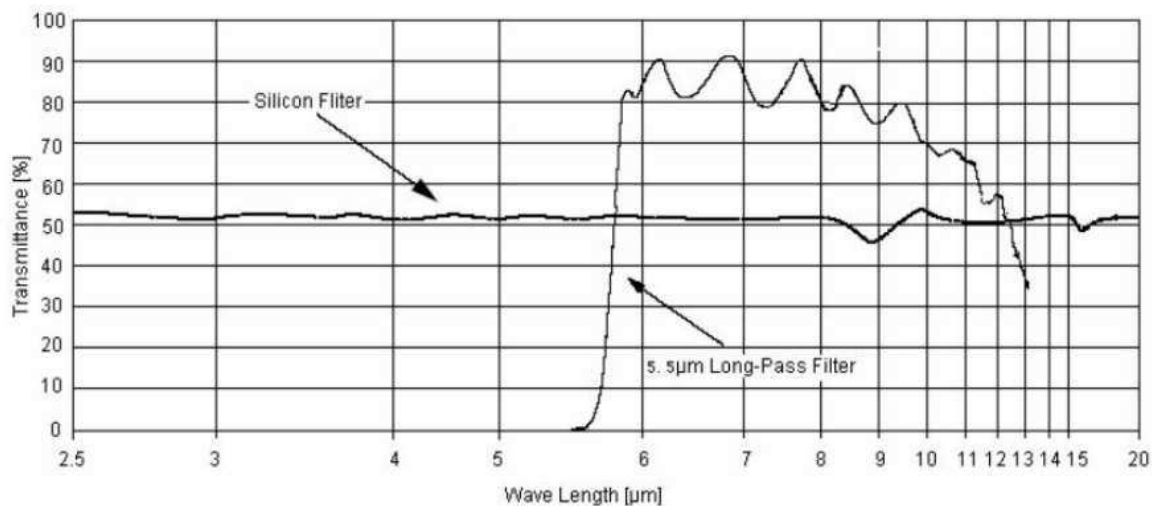

Note: The graph shows a typical 5 μm infrared filter reference, and the curve is the average of infrared pass rate. The window material is a special vacuum coating of semiconductor wafers.

Typical Application circuit

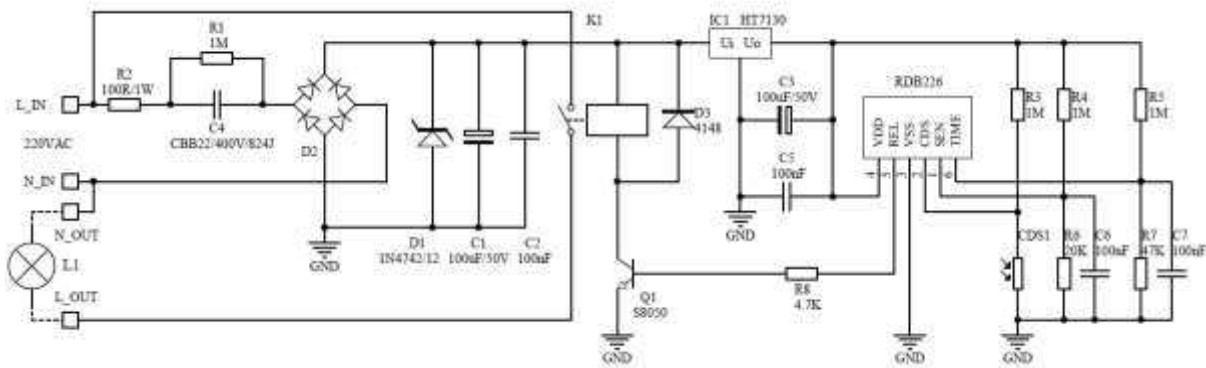

Cautions:

1. The sensor's parameter is obtained by standard testing condition after 1 minute's settling time.
2. Please pay attention on Sensor's window direction, must combine with Fresnel lens to get a perfect detecting angle.
3. Sensors detecting distance is affected by ambient temperature, moving objects' temperature, Fresnel lens, Amplifier amplification factor, the comparator threshold voltage setting...etc. please take a comprehensive consideration of various parameters when using the sensors.
4. Please do not touch the window area to avoid damaging to the optical filter.
5. Please handle the sensor with care when using it.
6. Please try to use hand soldering and make the soldering time as short as possible. Soldering temperature should be less than 350°C, and soldering time be less than 3 seconds.
7. Please get electrostatic protective measures when using this product, as applying static electricity of ±100V or more may damage the sensor.

Note: To keep continual product development, we reserve the right to change design features without prior notice.

Zhengzhou Winsen Electronics Technology Co., Ltd
Add: No.299, Jinsuo Road, National Hi-Tech Zone, Zhengzhou 450001 China
Tel: +86-371-67169097/67169670
Fax: +86-371-60932988
E-mail: sales@winsensor.com
Website: www.winsen-sensor.com