



HESTORE.HU

elektronikai alkatrész áruház

EN: This Datasheet is presented by the manufacturer.

Please visit our website for pricing and availability at www.hestore.hu.

AHT21 Product manuals

Temperature and Humidity sensor

- Full calibration
- Digital output, I²C interface
- Excellent long-term stability
- SMD package suitable for reflow soldering
- Quick response and strong anti-jamming capability



Product Overview

AHT21, as a new generation of temperature and humidity sensors, has established new standards in terms of size and performance: it is embedded in a double-row flat, leadless SMD package suitable for reflow welding, with a base of 3x3mm and a height of 0.8mm. The sensor outputs calibrated digital signals in standard I2C format.

AHT21 is equipped with a newly designed ASIC dedicated chip, an improved MEMS semiconductor capacitive humidity sensor element and a standard on-chip temperature sensor element. Its performance has been

greatly improved or even exceeded the reliability level of the previous generation of sensors. A generation of temperature and humidity sensors have been improved to make their performance more stable in harsh environments.

Each sensor is calibrated and tested, and the product lot number is printed on the surface of the product. Due to improvements and miniaturization of the sensor, it is more cost-effective, and ultimately all devices will benefit from cutting-edge energy-saving operation modes.

Application Scope

HVAC, dehumidifier, testing and inspection equipment, consumer products, automobiles, automatic control, data loggers, weather stations, home appliances, humidity control, medical and other related temperature and humidity detection and control.

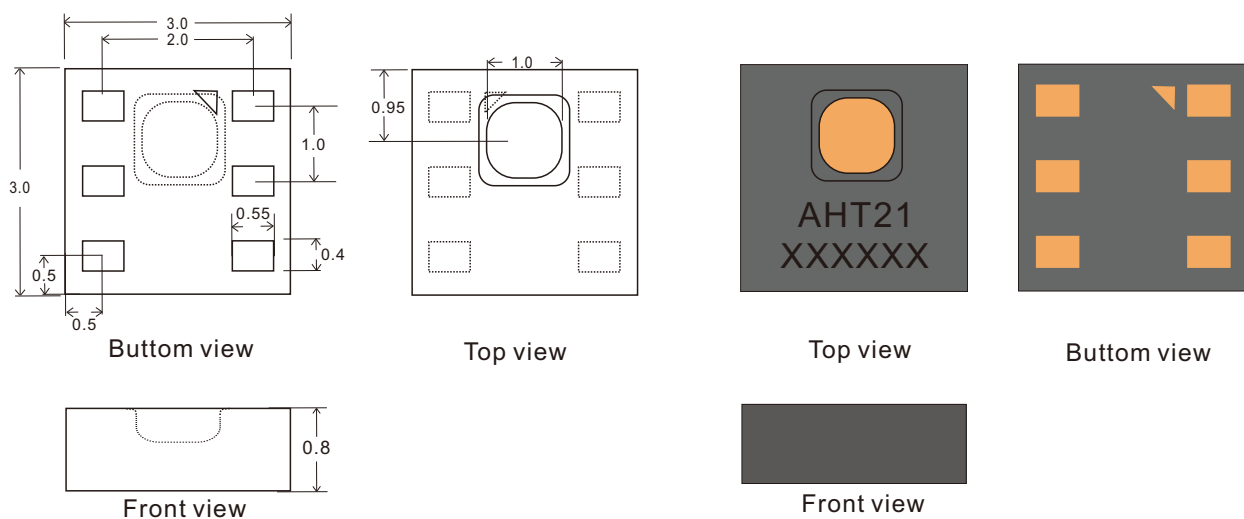

Figure 1: AHT21 Sensor Package Diagram (Unit: mm Tolerance: ±0.1 mm)

Sensor Performance

Relative Humidity

Parameter	Condition	Min	Typical	Max	Unit
resolution ratio	Typical		0.024		%RH
accuracy error ¹	Typical		±2		%RH
	Max	Figure 2			%RH
Repeatability			±0.1		%RH
Hysteresis			±1		%RH
Nonlinear			<0.1		%RH
Response time ²	t 63%		8		S
Scope of work	extended ³	0		100	%RH
Long time drift ⁴	Normal		<1		%RH/yr

Table 1 Humidity Characteristic

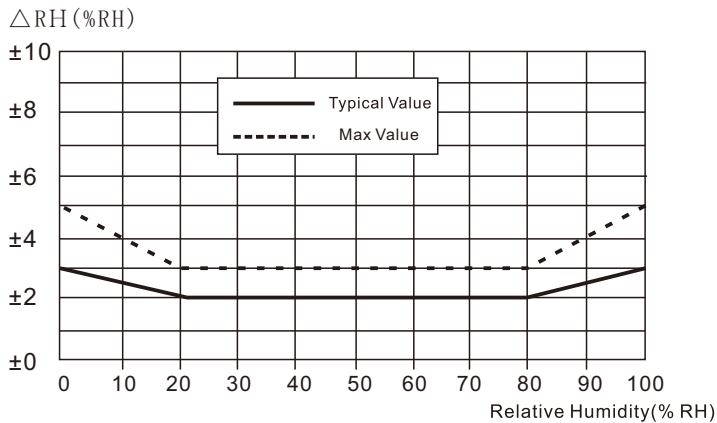

Figure 2 The maximum error of relative humidity at 25°C

Temperature

Parameter	Condition	Min	Typical	Max	Unit
resolution ratio	Typical		0.01		°C
accuracy error ¹	Typical		±0.3		°C
	Max	Figure 3			°C
Repeatability			±0.1		°C
Hysteresis			±0.1		°C
Response time ⁶	t 63%	5		30	S
Scope of work	extended ³	-40		120	°C
Long time drift			<0.1		°C/yr

Table 3 Temperature Characteristic

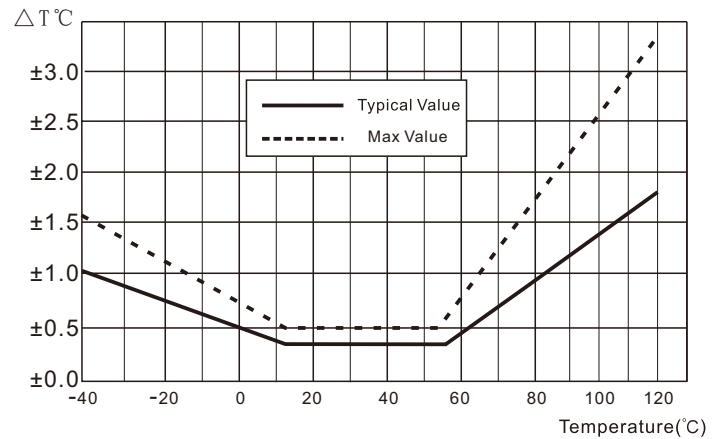

Figure 3 Typical error and maximum error of temperature

Electric Specification

Parameter	Condition	Min	Typical	Max	Unit
Voltage	Typical	2.0	3.3	5.5	V
Current, IDD ⁵	Dormant	-		250	nA
	Measure		980		μA
Power consumption ⁵	Dormant	-		0.8	μW
	Measure		3.2		mW
	Average	-	-	-	μW
Communication	Two-line digital interface, standard I ² C protocol				

Table 2 Electric Specification

- This accuracy is the test accuracy of the sensor when the power supply voltage is 3.3V at 25°C during factory inspection. This value does not include hysteresis and nonlinearity, and only applies to non-condensing conditions.
- Under the conditions of 25°C and 1m/s air flow, it takes time to reach 63% of the first-order response.
- Normal working range: 0-80%RH, beyond this range, the sensor reading will be biased (after 200 hours under 90%RH humidity, the drift is <3%RH).

Package Information

Sensor Model	Package	Quantity
AHT21	Tape package	5000PCS/Roll(MAX)

Table 4 Package

- If there are volatile solvents, tapes, adhesives, and packaging materials with pungent odors around the sensor, the readings may be high. For details, please refer to the relevant documents.
- The minimum and maximum power supply current and power consumption are based on the conditions of VDD = 3.3V and T < 60°C. The average value is the value measured every two seconds.
- Response time depends on the thermal conductivity of the sensor substrate.

AHT20 User Guide

1 Expansion of performance

1.1 Working Conditions

The sensor performance is stable in the suggested working scope, as shown in Figure 4. Long-term exposure to abnormal scope, especially when humidity > 80%, may lead to temporary signal drift (drift + 3% RH after 60 hours). When the sensor is restored to normal working conditions, it will slowly restore itself to the correct state. Refer to Recovery Processing in Section 2.3 to speed up the recovery process. Long-term use under abnormal conditions will accelerate the aging of products.

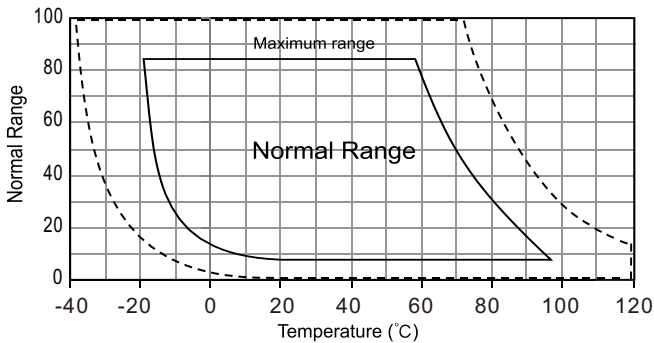

Figure 4 Working Conditions

1.2 RH Accuracy at Different Temperatures

The RH accuracy at 25°C is defined in Fig. 2, and the maximum humidity error at other temperatures is shown in Fig. 5.

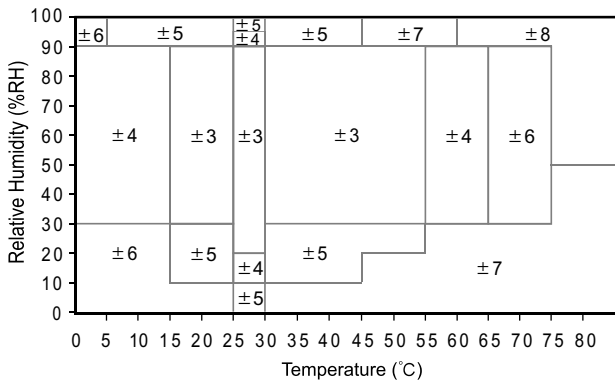

Figure 5 Maximum humidity error between 0~80 °C, unit: (% RH)

Note: Above errors are the tested maximum errors (excluding hysteresis) with the high precision dew-point instrument as reference instrument. The typical error is ± 2 % RH with the range of maximum error. In other scopes, the typical value is 1/2 of the maximum error.

1.3 Electric Specification

The power consumption given in Table 1 is related to temperature and supply voltage VDD. Estimated power consumption, see Figures 6 and 7. Note that the curves in Figures 6 and 7 are typical natural characteristics and may have deviations.

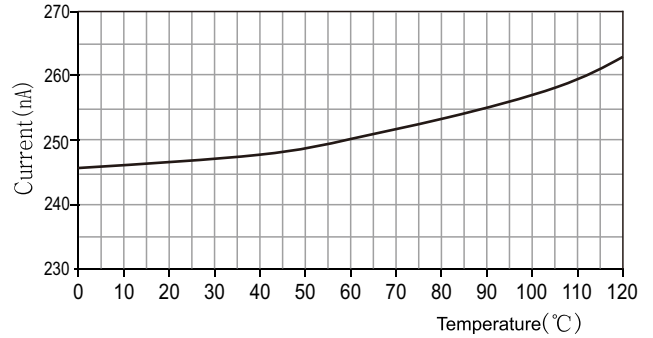

Figure 6 When VDD = 3.3V, the typical relationship between supply current and temperature (dormancy mode). Please note that there is a deviation of about ± 25% with the display value.

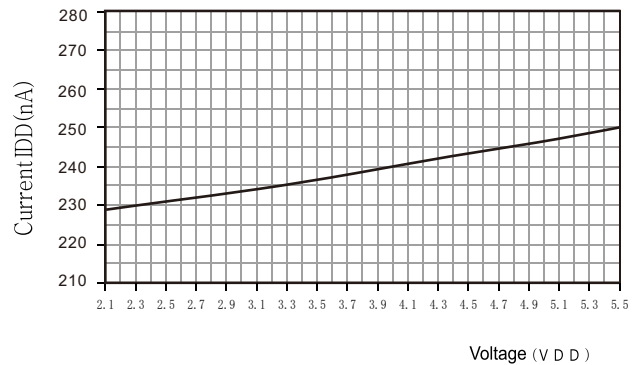

Figure 7 shows the typical relationship between supply current and voltage (dormancy mode) at 25 °C. Please be noted that the deviation between these data and the display value may reach ± 50 % of the display value. At 60 °C, the coefficient is about 15. (Compared with Table 2).

2 Application Information

2.1 Welding Specification

SMD I/O pads are made of copper lead frame plane substrates, except these pads are exposed and are used for mechanical and circuit connections. For use, both I/O pads and bare pads need to be soldered to the PCB. To prevent oxidation and optimize welding, the solder joints at the bottom of the sensor are coated with Ni/Au.

On the PCB, the length of the I/O contact surface⁷ should be 0.2-0.3mm larger than the sensor's I/O sealing pad, and the width should be 0.1-0.2mm larger than the sealing pad. The part near the inner side should match the shape of the I/O pad, and the ratio of the pin width to the SMD sealing pad width should be 1:1, as shown in Figure 8.

For mesh and solder layer designs⁸, it is recommended to use copper foil defined pads (SMD) with openings in the solder layer larger than the metal pads. For SMD pads, if the gap between the copper foil pads and the solder resistance layer is 60µm-75µm, the size of the solder resistance layer opening should be greater than the size of the pad 120µm-150µm. The square portion of the sealing pad shall match the corresponding square solder mask opening to ensure that there is sufficient solder mask area (especially at the corners) to prevent solder intersecting. Each pad shall have its own solder layer opening to form a network of solder layers around adjacent pads.

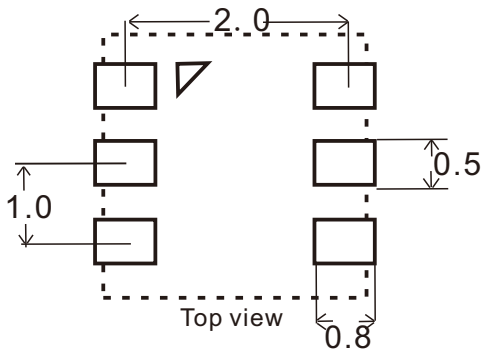

Figure 8 Recommended sensor PCB design size (unit: mm), the outer dotted line is the external size of the SMD package.

For solder printing, laser cutting stainless steel mesh with electronic polishing trapezoidal wall is recommended, with recommended thickness of 0.125 mm. The steel mesh size of the pad should be 0.1 mm longer than PCB pad and placed 0.1 mm away from the packaging center. Steel mesh with bare pads must cover 70% - 90% of the pad area - that is, the central position of the heat dissipation area reaches 1.4 mm x 2.3 mm.

Due to the low SMD mounting, it is recommended to use no-cleaning type 3 solders tin⁹ and to purify it with nitrogen during reflux.

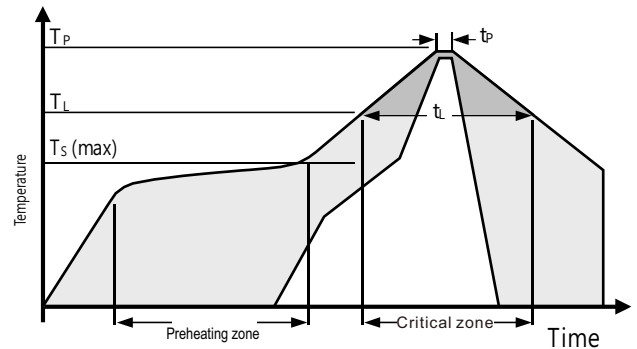

Figure 9 JEDEC Standard welding procedure diagram. $T_p \leq 260^\circ\text{C}$, $t_p < 30$ sec, lead-free welding. $T_L < 220^\circ\text{C}$, $t_L < 150$ sec, The rate of temperature rise and fall during welding shall be $< 5^\circ\text{C}/\text{sec}$.

Sensor can be welded through standard reflow furnace. The sensor fully meets the IPC/JEDEC J-STD-020D welding standard. The contact time should be less than 30 seconds at the highest 260°C (see Fig. 9) and the ultimate welding temperature that the sensor can withstand is 260°C, so it is recommended to use low temperature 180°C when reflow soldering.

Note: After reflow welding, the sensor should be stored at room temperature of 25°C and relative humidity greater than 75%RH for 12~72 hours, or placed at temperature of 60°C~85°C and relative humidity greater than 85%RH for 2~6 hours, to ensure the rehydration of the polymer, otherwise it will lead to sensor reading drift. Using low temperature reflow (e.g. 180°C) can reduce hydration time.

Don't wash the circuit boards is allowed after welding. Therefore, it is suggested that customers use "wash-free" solder paste. If the sensor is applied to corrosive gases, condensate water may be produced (e.g. in high humidity environment), both pin pads and PCB need to be sealed (e.g. using conformal coating) to avoid poor contact or short circuit.

2.2 Storage conditions and instructions

The humidity sensitivity level (MSL) is 1, according to IPC/JEDEC J-STD-020 standard. Therefore, it is recommended to use it within one year after delivery.

Humidity sensor is not an ordinary electronic component, and it needs careful protection, which users must pay attention to. Long-term exposure to high concentration of chemical vapor will cause the sensor reading to drift.

⁷Contact surface refers to the metal layer on PCB where SMD pads are welded.

⁸The solder mask layer refers to the insulating layer covering the connecting line at the top of the PCB.

⁹The type of solder is related to the size of particles in solder. Type 3 powder in size range of 25-45 µm.

Therefore, it is recommended that the sensor be stored in the original package including sealed ESD bag, and meet the following conditions: temperature range 10~50°C(0~85°C in a limited time), humidity 20~60% RH(no ESD packaged sensor). For sensors that they be stored in antistatic bags made of metal PET/AL/CPE.

During production and transportation, sensors should avoid exposure to high concentration of chemical solvents and prolonged exposure. Avoid exposure to volatile glue, adhesive tape, stickers or volatile packaging materials, such as foamed foil, foam material, etc. The production area should be well ventilated.

2.3 Recovery processing

As mentioned above, the readings can drift if the sensor is exposed to extreme operating conditions or chemical vapors. It can be restored to the calibration state by the following processing.

If the humidity is high, take drying measures: keep it at 60-85°C and <5%RH for 2-10 hours until recovery; If the humidity is low, it can be rehydrated. Refer to Section 2.1 for reflow soldering after rehydration treatment.

2.4 Temperature influence

The relative humidity of gases depends largely on temperature. Therefore, when measuring humidity, all sensors measuring the same humidity should work at the same temperature as possible. When testing, it is necessary to ensure that the same temperature, and then compare the humidity readings.

If the sensor and the heating-prone electronic components are placed on the same printing circuit board, measures should be taken to minimize the effect of heat transfer as far as possible in the design of the circuit.

For example, to maintain good ventilation of the shell, the copper coating of AHT21 and other parts of the printed circuit board should be as small as possible, or leave a gap between them. (See Fig. 10)

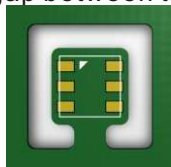

Figure 10 The top view of AHT21 printed circuit board, the design of the milling slit is added in the figure, The heat transfer can be reduced to a minimum.

In addition, when the measurement frequency is too high, the temperature of the sensor itself will rise and affect the measurement accuracy. In order to ensure that its own temperature rise is low by 0.1°C, it is recommended that the IIC frequency should be between 10K and 400KHz during measurement, and should not be too high, and the data collection cycle should be greater than 1 second/time.

2.5 Product application scenario design

In product design, the sensor has following characteristics:

1) Sensor is in full contact with the outside air

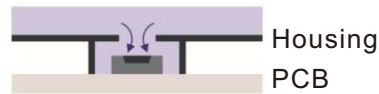

Figure 11: Suitable windows on the enclosure provide good access to environmental measurements and allow for greater air exchange.

2) The sensor is completely isolated from the air inside the housing

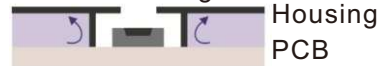

Figure 12: The sensor is isolated from the air inside the housing, which minimizes the impact of the air inside the housing on the sensor.

3) Small measurement dead zone around the sensor



Figure 13: Small measurement dead zone helps the sensor to quickly and comprehensively detect environmental changes.

4) The sensor is isolated from the heat

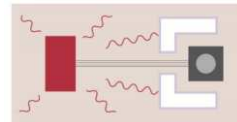

Figure 14: The sensor is isolated from the internal heat source to minimize the effect of internal heat on sensor.

5) The sensor power supply can be controlled

In order to improve the stability of the system, the following power supply controllable scheme is provided:

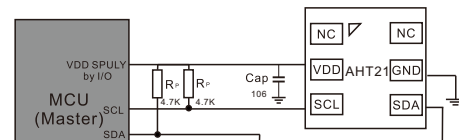

Figure 15 Typical application circuit, the pull-up voltage and VDD of SCL and SDA are powered by the MCU.

Note: 1. The power supply voltage range of the host MCU to the sensor is 2.0~5.5V.

2. When the sensor is just powered on, MCU gives priority to VDD power supply, and SCL and SDA high levels can be set after 5ms.

6) The wiring rules of the sensor on the PCB

In order to improve the reliability of the sensor, the layout of the circuit board should be avoided in the bottom of the sensor wiring or copper design.

2.6 Material used for sealing and encapsulation

Many materials absorb moisture and act as buffer, which will increase response time and hysteresis. Therefore, the material around the sensor should be carefully selected. Recommended materials are: Metal materials, LCP, POM (Delrin), PTFE (Teflon), PE, PEEK, PP, PB, PPS, PSU, PVDF, and PVF. Material for sealing and bonding (conservative recommendation): It is recommended to use method of filling epoxy resin or silicone resin for packaging electronic components. Gases released from these materials may also contaminate sensor (see 2.2). Therefore, the sensor should be finally assembled and placed in a well-ventilated place, or dried for 24 hours in an environment of > 50°C, in order to release the contaminated gas before packaging.

2.7 Wiring rules and signal integrity

If the SCL and SDA signal lines are parallel and very close to each other, it may cause signal crosstalk and communication failure. The solution is to place VDD and/or GND between the two signal lines, separate the signal lines, and use shielded cables. In addition, reducing the SCL frequency may also improve the integrity of signal transmission. A 10µF decoupling capacitor must be added between the power supply pins (VDD, GND) for filtering. This capacitor should be as close as possible to the sensor. See the next chapter.

3 Interface Definition

Pin	Name	Definition		
1	NC	Remain suspended		
2	VDD	Power supply voltage	NC	NC
3	SCL	Serial clock	VDD	GND
4	SDA	Serial data, bidirectional	SCL	SDA
5	GND	Power ground		
6	NC	Remain suspended		

Top view

Table 5 Sensor pin distribution (top view).

3.1 Power Pins (VDD,GND)

The power supply range of the sensor is 2.0-5.5V, and the recommended voltage is 3.3V. A decoupling capacitor of 10µF must be added between VDD and GND to play a filtering role. VDD is better than SDA and SCL power on or synchronous power on, to avoid the signal line (SCL/SDA) leakage current into the chip, resulting in power on the chip in the non-working state.

3.2 Serial clock SCL

SCL is used to synchronize the communication between microprocessor and sensor. Because the interface contains complete static logic, there is no minimum SCL frequency.

3.3 Serial data SDA

SDA pins are used for data input and output of the sensor. The SDA is effective on the rising edge of the serial clock SCL when sending commands to the sensor, and the SDA must remain stable when the SCL is at high levels. After the SCL falling edge, the SDA value can be changed. To ensure communication security, the effective time of SDA should be extended to TSU and THO before the rising edge of SCL, and after the falling edge of SCL - refer to Figure 17. When reading data from the sensor, the SDA is effective after the SCL is low (TV) and remains until the falling edge of the next SCL.

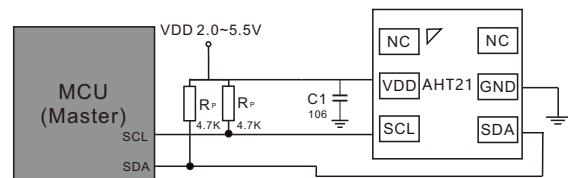

Figure 16 Typical application circuit

- Note:
1. The pull-up voltage of SCL and SDA must be powered by VDD, and the power supply voltage range is 2.0 ~ 5.5V;
 2. Add 10µF decoupling capacitor between VDD and GND
 3. In order to ensure that the sensor is not disturbed by the circuit, please add filter circuit to the VDD, such as C1 on the typical circuit.

To avoid conflict of signal, the microprocessor (MCU) must be driven SDA and SCL only at low level, need an external pull-up resistors (for example: 2.0 ~ 4.7 K Ω) will lift the signals to high level, pull-up resistance may have often included in a microprocessor I/O circuits. Refer to Tables 7 and 8 for detailed information on sensor input/output characteristics.

4 Electric Specification

4.1 Absolute Maximum Rating

The electric specifications of sensor are defined in Table 2. The absolute maximum ratings given in Table 6 are only stress ratings and to provide more information. Under such conditions, it is not advisable for the device to perform functional operation. Exposure to absolute maximum rating or a long time may affect the reliability of the sensor.

Parameters	Min	Max	Unit
VDD to GND	-0.3	5.5	V
Digital I/O pin (SDA, SCL) to GND	-0.3	VDD + 0.3	V
Input current for each pin	-10	10	mA

Table 6 Absolute maximum electric rating

ESD electrostatic discharge conforms to JEDEC JESD22-A114 standard (human body mode $\pm 4kV$) and JEDEC JESD22-A115 (machine mode $\pm 200V$) If the test condition exceeds the nominal limit, the sensor needs additional protection circuit.

4.2 Input/output characteristics

Electrical characteristics, such as power consumption, high and low level voltages of input and output, depend on the power supply voltage. In order for the sensor to communicate smoothly, ensure that the signal is strictly limited within the range shown in Table 7, 8, and Figure 17

Parameter	Condition	Min	Typic	Max	Unit
Output low voltage VOL	VDD = 3.3 V, -4 mA < IOL < 0mA	0	-	0.4	V
Output high voltage VOH		70% VDD	-	VDD	V
Output sink current IOL		-	-	-4	mA
Input low voltage VIL		0	-	30% VDD	V
Input high voltage VIH		70% VDD	-	VDD	V
Input current	VDD = 5.5 V, VIN = 0 V to 5.5 V	-	-	± 1	μA

Table 7 Direct current characteristics of DIO pads, if without special declaration, VDD=2.0V to 5.5V, T=-40°C to 120°C.

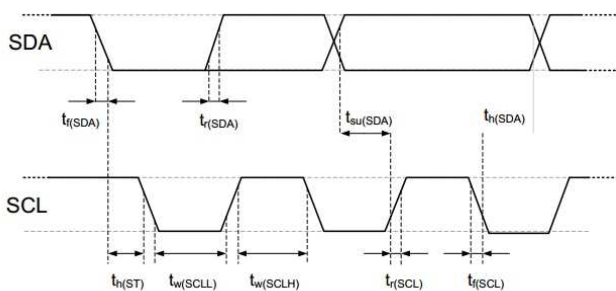

Figure 17 The sequence diagrams and abbreviations of digital input/output are explained in Table 8. Thicker SDA lines are controlled by sensors, and ordinary SDA lines are controlled by single chip computer. Please be noted that the effective read time of SDA is triggered by the drop edge of the previous conversion

Parameter	Mark	I ² C Typical Mode		I ² C High speed mode		Unit
		MIN	MAX	MIN	MAX	
I ² C clock frequency	fSCL	0	100	0	400	KHz
Initial signal time	tHDSTA					μs
SCL Clock High Level Width	tHIGH	4.7		1.3		μs
SCL Clock Low Level Width	tLOW	4.0		0.6		μs
Data save time relative to SCL SDA edge	tHDDAT	0.09	3.45	0.02	0.9	μs
Data Setting Time Relative to SCL SDA Edge	tSUDAT	250		100		μs

Note: Both pins are measured from 0.2 VDD and 0.8 VDD.
 Note: The above I²C time serial is determined by the following internal delays:
 (1) The internal SDI input pins are delayed relative to SCK pins with a typical value of 100ns.
 (2) The internal SDI output pin is delayed relative to SCK falling edge with a typical value of 200 ns.

Table 8. I²C Sequence Characteristics of Digital Input/output in fast Mode. The specific meaning is shown in Figure 12. Unless otherwise indicated

5 Sensor Communication

Sensor adopts standard I²C protocol to communicate. For information on the I²C protocol except the following chapters, please refer to the following website: www.aosong.com for sample reference.

5.1 Start Sensor

The first step is to power the sensor at the selected VDD supply voltage (between 2.0V and 5.5V). After power on, the sensor needs 100ms~500ms time (where SCL is at high level) to reach idle state, which is ready to receive commands sent by the host computer (MCU).

5.2 Timing sequence of start/stop

Each transport sequence starts with the Start state and ends with the Stop state, as shown in Figures 18 and 19.

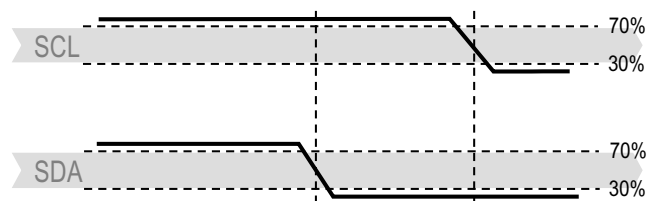

Figure 18 Start Transmit State (S) - When SCL is at high level, SDA is converted from high level to low level. The start state is a special bus state controlled by the main engine, indicating the start of slave machine transit (after Start, BUS is generally considered to be in a busy state).

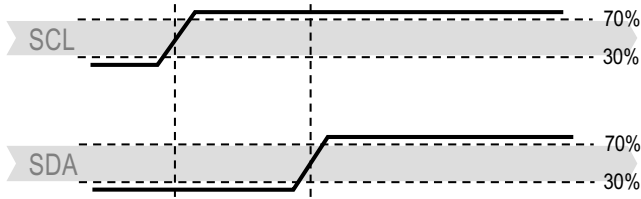
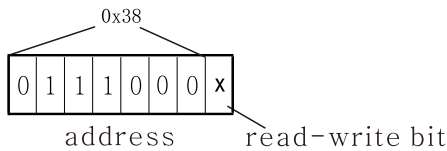

Figure 19 Stop Transmit State (P) - When the SCL is at high level, the SDA line is converted from low level to high level. Stop state is a special bus state controlled by the main engine, indicating the end of slave machine transmit (after Stop, BUS is generally considered to be in idle state).

5.3 Send Command

After the transmission is started, the first byte of I2C that is subsequently transmitted consists of the 7-bit I2C device address 0x38 and an SDA direction bit X (read R: '1', write W: '0 ').After the eighth SCL clock falling edge, the sensor data reception is normal by pulling down the SDA pin (ACK bit).After sending the measurement command 0xAC, the MCU must wait until the measurement is complete.



Bit	Definition	Description
Bit[7]	(Busy indication)	1 -- Busy in measurement 0 -- Free in dormant state
Bit [6:5]	Remained	Remained
Bit [4]	Remained	Remained
Bit [3]	CAL Enable	1--calibrated 0--uncalibrated
Bit [2:0]	Remained	Remained

Table 9 Status bit specification

5.4 Sensor reading process

1. After power on, wait for 100ms~500ms. Before reading the temperature and humidity values, send 0x71 to get a byte status word. If the state word and 0x18 are not equal to 0x18, initialize the registers 0x1B, 0x1C and 0x1E. For detailed initialization process, please refer to our official website routine; If equal, proceed to the next step

2. Wait for 10ms to send the 0xAC command (trigger measurement), which takes two bytes, the first byte is 0x30, and the second byte is 0x00.

3. Wait for 250ms to complete the measurement. If the read status word Bit[7] is 0, it means the measurement is completed, and then six bytes can be read continuously. Otherwise, keep waiting.

4. After receiving six bytes, the next byte is CRC check data, which the user can read as needed. If the receiver needs CRC check, it will send an ACK reply after receiving the sixth byte, otherwise it will send a NACK reply. The initial value of CRC is 0xFF, and the CRC8 check polynomial is:

$$CRC[7:0]=1+x^4+ x^5+ x^8$$

5. Calculate the temperature and humidity values.

Note: The calibration status check in the first step only needs to be checked at power-on. No operation is required during the normal acquisition process.

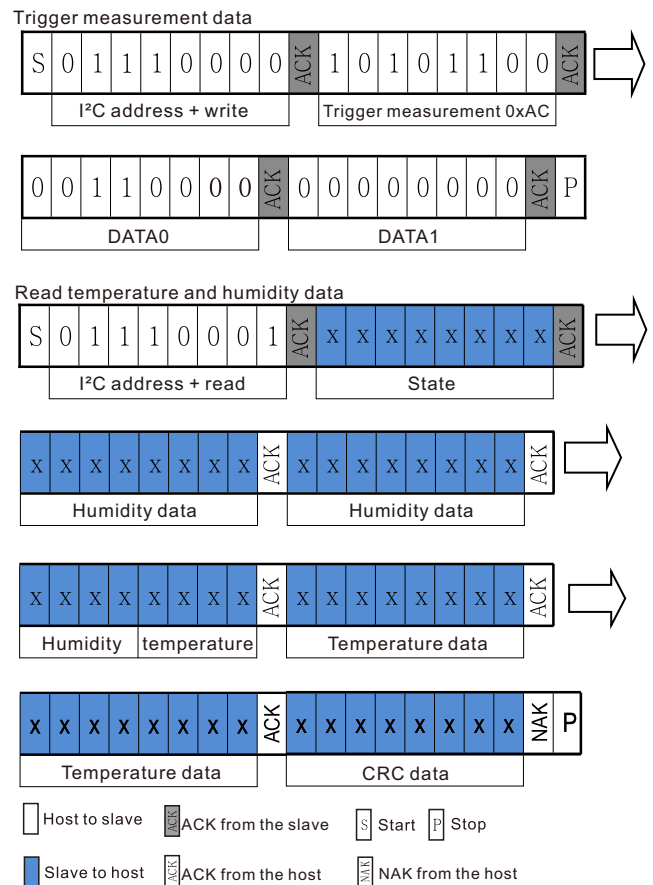

Note: It takes time for the sensor to collect. After the host sends out the measurement instruction (0xAC), it will delay more than 250 milliseconds to read the converted data and judge whether the returned status bit is normal. If the state bit [Bit7] is 0, it means that the data can be read normally. If the state bit [Bit7] is 1, the sensor is in a busy state, and the host needs to wait for the completion of data processing.

6 Signal Transformation

6.1 Relative humidity transformation

Relative humidity RH can be calculated according to the relative humidity signal S_{RH} output from SDA by the following equation. (The result is expressed in % RH)

$$RH[\%]=\left(\frac{S_{RH}}{2^{20}}\right)*100\%$$

6.2 Temperature transformation

Temperature T can be calculated by substituting the temperature output signal S_T into the following formula. (The results are expressed as temperature °C)

$$T(^{\circ}C)=\left(\frac{S_T}{2^{20}}\right)*200-50$$

7 Environmental stability

If the sensor is used in equipment or machinery, please make sure that it is the same temperature and humidity that the sensor used for measurement and the sensor used for reference that have sensed. If the sensor is placed in the equipment, the reaction time will be prolonged, so it is necessary to ensure that sufficient measurement time is reserved in the programming. The sensor is tested according to the enterprise standard of Aosong temperature and humidity sensor. The performance of sensors under other test conditions is not guaranteed and cannot be regarded as a part of sensor performance. Especially for the specific occasions required by users, we do not make any commitments.

8 Package

Sensor provides SMD packaging (similar to DFN), which represents a bilateral flat and pin-free package. The sensor chip is made of a copper lead frame coated with Ni/Au. The weight of the sensor is about 19 mg.

8.1 Trace Information

All sensors have laser labels on their surfaces. See Figure 20.



Figure 20: Sensor laser label

A label is also attached to the tape, as shown in Figure 21, and other trace information is provided.

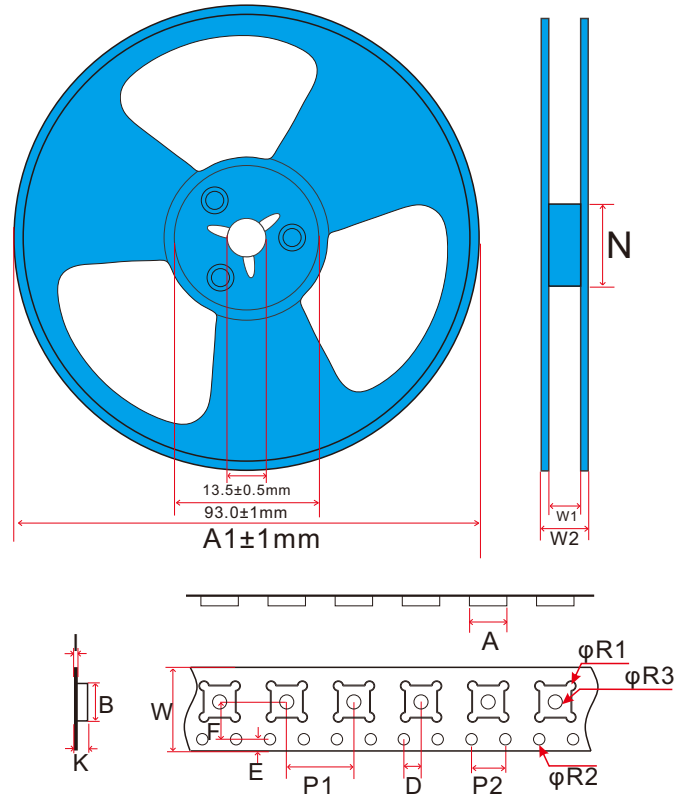

Figure 21: Label on the tape

8.2 Transport Package

Sensor is packaged in tape and reel, sealed in an antistatic ESD bag. The standard packaging size is 5000 sheets per roll. For sensor packaging, the 440mm (Approximately 55 sensor capacity) and the front 200mm (Approximately 30 sensor capacity) part of each reel is empty.

The packaging diagram with sensor positioning is shown in Figure 22. The reel is placed in an anti-static pocket



Model	A1	E	W1	W2	N
AHT21 scroll	233/330	2	12	16	100

Model	Unit	Tolerance	Quantity	Weight
AHT21 scroll	mm	±0.5	5000(MAX)	500/g

Model	A/B	K	W	φR2/φR3	φR1
AHT21 taping	3.25 ^{+0.1} _{-0.0}	1.25 ^{+0.1} _{-0.0}	12.0±0.3	1.50 ^{+0.1} _{-0.0}	0.50 ^{+0.1} _{-0.0}

Model	P1	P2	I	F	E	D
AHT21 taping	8.0±0.1	4.0±0.1	0.3±0.05	5.5±0.1	1.75±0.1	2.0±0.1

Figure 22: Package tape and sensor location diagram

Attention

Warning of personal injury

Do not apply this product to safety protection devices or emergency stop equipment, as well as any other applications that may cause personal injury due to the failure of the product. This product cannot be used unless there is a special purpose or with an authorization to use it. Please refer to the product data sheet and Application guide before installing, processing, using or maintaining the product. Failure to comply with this recommendation may result in death and serious bodily injury.

If the Buyer intends to purchase or use the Aosong products without any application license and authorization, the buyer shall bear all compensation for personal injury and death resulting therefrom, and shall not claim for compensation including various costs, compensation fees, lawyers, etc. Expenses and so on with the managers and employees of Aosong Company, as well as subsidiaries, agents, distributors, etc.

ESD Protection

Due to the inherent component design, it is sensitive to static electricity. In order to prevent the damage and the reduction of the product's performance caused by static electricity, the necessary anti-static measures should be taken when applying this product.

Quality Assurance

Our company provides 12-month (1-year) quality assurance for buyers of its products (calculated from the date of delivery) based on the technical specifications in the data manual of the product published by Aosong. If the product is found to be defective under warranty, our company will provide free maintenance or replacement. Users need to satisfy the following conditions:

- Notify our company in writing within 14 days after the defect is found
- The defect of this product will help to find out the deficiency in design, material and technology of our product.
- The product should be sent back to our company at the buyer's expense.
- The product should be under warranty.

Our company is only responsible for the defective products which are used in the occasions that meet the technical requirements of the product. Our company makes no warranties or written representations regarding the use of its products in special application occasions.

At the same time, the company does not make any commitment to the reliability of the products applied to products or circuits.

Copyright©2020, ASAIR®