



HESTORE.HU

elektronikai alkatrész áruház

EN: This Datasheet is presented by the manufacturer.

Please visit our website for pricing and availability at www.hestore.hu.

3A, 23V, 340KHz Synchronous Rectified Step-Down Converter

MP1484

■ Features

- 3A Continuous Output Current
- Wide 4.75V to 23V Operating Input Range
- Integrated 85mΩ Power MOSFET Switches
- Output Adjustable from 0.925V to 20V
- Up to 95% Efficiency
- Programmable Soft-Start
- Stable with Low ESR Ceramic Output Capacitors
- Fixed 340KHz Frequency
- Cycle-by-Cycle Over Current Protection
- Input Under Voltage Lockout

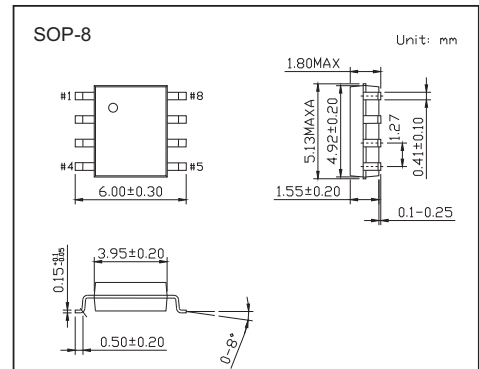

■ Functional Block Diagram

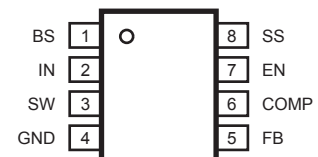
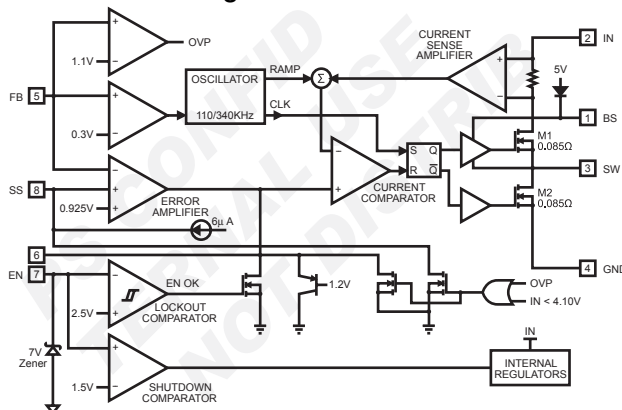

■ Absolute Maximum Ratings $T_a = 25^\circ\text{C}$

Parameter	Symbol	Rating	Unit
Input Voltage	V_{in}	-0.3 to 24	V
Switch Voltage	V_{sw}	-1 to $V_{in} + 0.3$	V
Boot Strap Voltage	V_{BS}	$V_{sw} - 0.3\text{V}$ to $V_{sw} + 6$	V
All Other Pins		-0.3 to 6V	V
Power Dissipation	P_D	2.5	mW
Thermal Resistance	$R_{\theta JA}$	50	$^\circ\text{C}/\text{W}$
Junction Temperature	T_j	150	$^\circ\text{C}$
Storage Temperature	T_{stg}	-65 to 150	$^\circ\text{C}$
Lead Temperature	T_L	260	$^\circ\text{C}$

■ Recommended Operating Conditions

Input Voltage	V_{in}	4.75 to 23	V
Output Voltage	V_{out}	0.925 to 20	V
Operating Temperature	T_A	-20 to 85	$^\circ\text{C}$

MP1484

■ Electrical Characteristics (Ta = 25°C , VIN=12V, unless otherwise specified)

Parameter	Symbol	Condition	Min	Typ	Max	Units
Shutdown Supply Current		V _{EN} = 0V		0.3	3.0	μA
Supply Current		V _{EN} = 2.0V, V _{FB} = 1.0V		1.3	1.5	mA
Feedback Voltage	V _{FB}	4.75V ≤ V _{IN} ≤ 23V	0.900	0.925	0.950	V
Feedback Overvoltage Threshold				1.1		V
Error Amplifier Voltage Gain ⁽⁴⁾	A _{EA}			400		V/V
Error Amplifier Transconductance	G _{EA}	ΔI _C = ±10μA		820		μA/V
High-Side/Low-Side Switch On-Resistance ⁽⁴⁾				85		mΩ
High-Side Switch Leakage Current		V _{EN} = 0V, V _{SW} = 0V		0	10	μA
Upper Switch Current Limit		Minimum Duty Cycle	3.8	5.3		A
Lower Switch Current Limit		From Drain to Source		0.9		A
COMP to Current Sense Transconductance	G _{CS}			5.2		A/V
Oscillation Frequency	F _{osc1}		300	340	380	KHz
Short Circuit Oscillation Frequency	F _{osc2}	V _{FB} = 0V		110		KHz
Maximum Duty Cycle	D _{MAX}	V _{FB} = 1.0V		90		%
Minimum On Time ⁽⁴⁾	T _{ON}			220		ns
EN Shutdown Threshold Voltage		V _{EN} Rising	1.1	1.5	2.0	V
EN Shutdown Threshold Voltage Hysteresis				220		mV
EN Lockout Threshold Voltage			2.2	2.5	2.7	V
EN Lockout Hysteresis				210		mV
Input Under Voltage Lockout Threshold		V _{IN} Rising	3.80	4.05	4.40	V
Input Under Voltage Lockout Threshold Hysteresis				210		mV
Soft-Start Current		V _{SS} = 0V		6		μA
Soft-Start Period		C _{SS} = 0.1μF		15		ms
Thermal Shutdown ⁽¹⁾				160		°C

Note:

1) Guaranteed by design, not tested.

■ TypIacl Characteristics

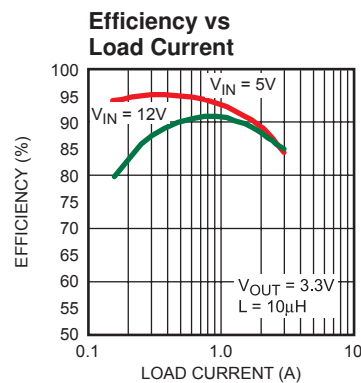
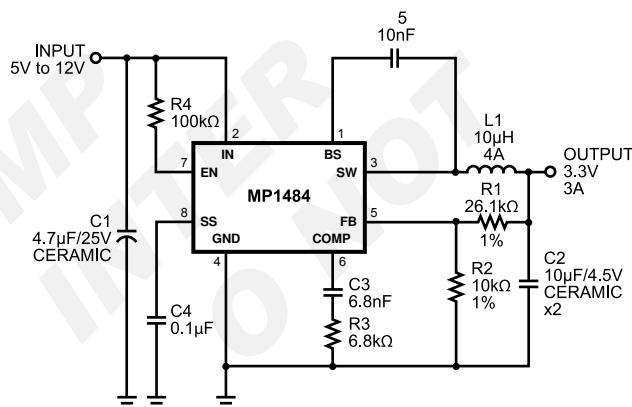

MP1484

■ Typical Characteristics

Steady State Test Waveforms

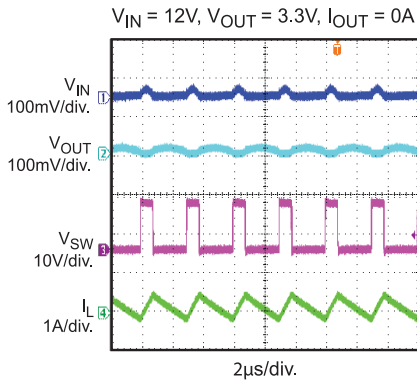

Steady State Test Waveforms

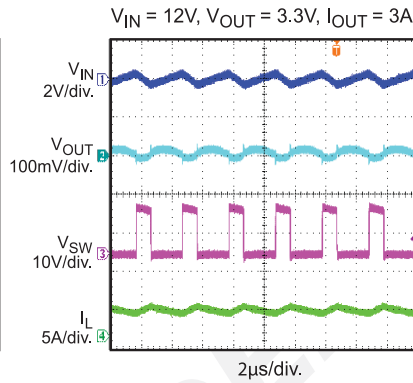

Startup through Enable Waveforms

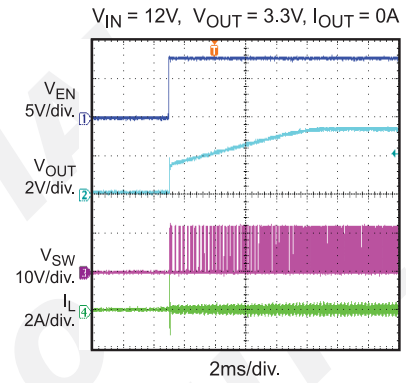

Startup Through Enable Waveforms

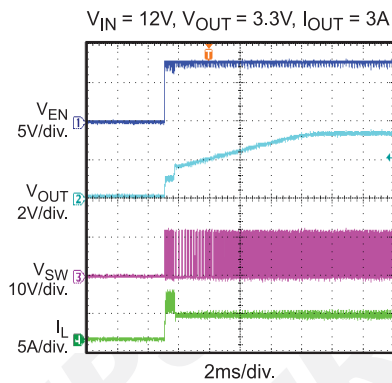

Shutdown Through Enable Waveforms

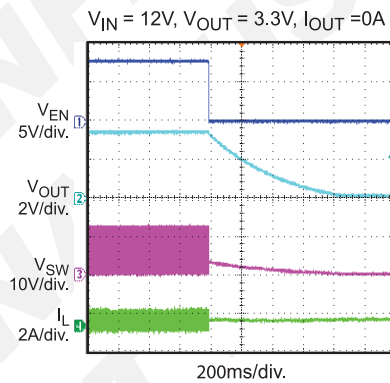

Shutdown Through Enable Waveforms

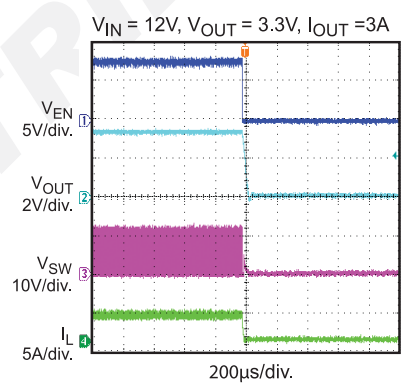

Load Transient Test Waveforms

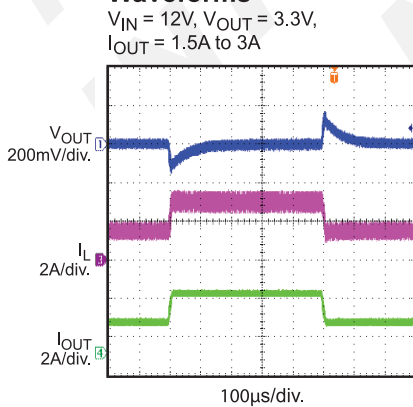

Short Circuit Test Waveforms

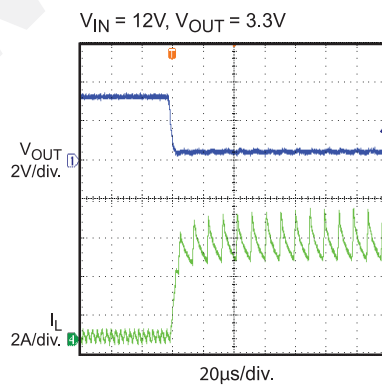

Short Circuit Recovery Waveforms

