



HESTORE.HU

elektronikai alkatrész áruház

EN: This Datasheet is presented by the manufacturer.

Please visit our website for pricing and availability at www.hestore.hu.

PRODUCT DATA SHEET

Part Number: W577

Type	Size	Rating	Description
Incandescent	T10	12V 3W	T-3¼ Miniature Edison Screw lamp

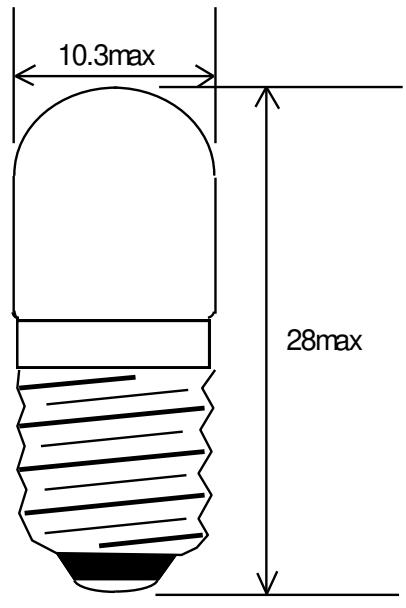

Dimensions in mm.

TEST VOLTS	CURRENT (mA)			LIGHT OUTPUT (Lm)			LIFE Hours
	Min.	Nom.	Max.	Min.	Nom.	Max.	
12	225	250	275	10.0	12.5	15.0	4,000

Notes:

- 1 **Base Type** E10/13 Nickel plated brass
- 2 **Filament Shape** C-2F
- 3 **Bead Colour** White or clear
- 4 **Marking** CML 12V 3W
- 5 **Environmental** RoHS & REACH SVHC compliant