



HESTORE.HU

elektronikai alkatrész áruház

EN: This Datasheet is presented by the manufacturer.

Please visit our website for pricing and availability at www.hestore.hu.

Transmissive Optical Sensor with Phototransistor Output

Description

The TCST1103/1202/1300/2103/2202/2300 are transmissive sensors that include an infrared emitter and phototransistor, located face-to-face on the optical axes in a leaded package which blocks visible light. These part numbers include options for aperture width and mounting flanges.

Features

- Package type: Leaded
- Detector type: Phototransistor
- Dimensions package A:
L 11.9 mm x W 6.3 mm x H 10.8 mm
- Dimensions package B:
L 24.5 mm x W 6.3 mm x H 10.8 mm
- Gap: 3.1 mm
- Typical output current under test: $I_C = 4 \text{ mA}$ (TCST1103/2103)
- Typical output current under test: $I_C = 2 \text{ mA}$ (TCST1202/2202)
- Typical output current under test: $I_C = 0.5 \text{ mA}$ (TCST1300/2300)

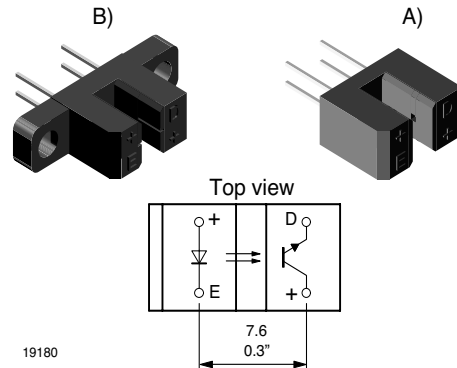

- Daylight blocking filter
- Emitter wavelength 950 nm
- Lead (Pb)-free soldering released
- Lead (Pb)-free component in accordance to RoHS 2002/95/EC and WEEE 2002/96/EC

Applications

- Optical switch
- Photo interrupter
- Counter
- Encoder

Order Instructions

Part Number	Remarks	Resolution, Aperture	Minimum Order Quantity
TCST1103	Without mounting flange ^{A)}	0.6 mm, 1 mm	1020 pcs, 85 pcs/tube
TCST1202	Without mounting flange ^{A)}	0.4 mm, 0.5 mm	1020 pcs, 85 pcs/tube
TCST1300	Without mounting flange ^{A)}	0.2 mm, 0.25 mm	1020 pcs, 85 pcs/tube
TCST2103	With mounting flange ^{B)}	0.6 mm, 1 mm	1020 pcs, 85 pcs/tube
TCST2202	With mounting flange ^{B)}	0.4 mm, 0.5 mm	1020 pcs, 85 pcs/tube
TCST2300	With mounting flange ^{B)}	0.2 mm, 0.25 mm	1020 pcs, 85 pcs/tube

Absolute Maximum Ratings

$T_{amb} = 25 \text{ }^\circ\text{C}$, unless otherwise specified

Coupler

Parameter	Test condition	Symbol	Value	Unit
Total power dissipation	$T_{amb} \leq 25 \text{ }^\circ\text{C}$	P_{tot}	250	mW
Operating temperature range		T_{amb}	- 55 to + 85	$^\circ\text{C}$
Storage temperature range		T_{stg}	- 55 to + 100	$^\circ\text{C}$
Soldering temperature	Distance to package: 2 mm; $t \leq 5 \text{ s}$	T_{sd}	260	$^\circ\text{C}$

Input (Emitter)

Parameter	Test condition	Symbol	Value	Unit
Reverse voltage		V_R	6	V
Forward current		I_F	60	mA
Forward surge current	$t_p \leq 10 \mu s$	I_{FSM}	3	A
Power dissipation	$T_{amb} \leq 25^\circ C$	P_V	100	mW
Junction temperature		T_j	100	$^\circ C$

Output (Detector)

Parameter	Test condition	Symbol	Value	Unit
Collector emitter voltage		V_{CEO}	70	V
Emitter collector voltage		V_{ECO}	7	V
Collector current		I_C	100	mA
Collector peak current	$t_p/T = 0.5, t_p \leq 10 ms$	I_{CM}	200	mA
Power dissipation	$T_{amb} \leq 25^\circ C$	P_V	150	mW
Junction temperature		T_j	100	$^\circ C$

Electrical Characteristics

$T_{amb} = 25^\circ C$, unless otherwise specified

Coupler

Parameter	Test condition	Part	Symbol	Min	Typ.	Max	Unit
Current Transfer Ratio	$V_{CE} = 5 V, I_F = 20 mA$	TCST1103, TCST2103	CTR	10	20		%
		TCST1202, TCST2202	CTR	5	10		%
		TCST1300, TCST2300	CTR	1.25	2.5		%
Collector current	$V_{CE} = 5 V, I_F = 20 mA$	TCST1103, TCST2103	I_C	2	4		mA
		TCST1202, TCST2202	I_C	1	2		mA
		TCST1300, TCST2300	I_C	0.25	0.5		mA
Collector emitter saturation voltage	$I_F = 20 mA, I_C = 1 mA$	TCST1103, TCST2103	V_{CEsat}			0.4	V
	$I_F = 20 mA, I_C = 0.5 mA$	TCST1202, TCST2202	V_{CEsat}			0.4	V
	$I_F = 20 mA, I_C = 0.1 mA$	TCST1300, TCST2300	V_{CEsat}			0.4	V
Resolution, path of the shutter crossing the radiant sensitive zone	$I_{Crel} = 10 to 90 \%$	TCST1103, TCST2103	s		0.6		mm
		TCST1202, TCST2202	s		0.4		mm
		TCST1300, TCST2300	s		0.2		mm

Input (Emitter)

Parameter	Test condition	Symbol	Min	Typ.	Max	Unit
Forward voltage	$I_F = 60 mA$	V_F		1.25	1.6	V
Junction capacitance	$V_R = 0, f = 1 MHz$	C_j		50		pF

Output (Detector)

Parameter	Test condition	Symbol	Min	Typ.	Max	Unit
Collector emitter voltage	$I_C = 1 \text{ mA}$	V_{CEO}	70			V
Emitter collector voltage	$I_E = 10 \text{ } \mu\text{A}$	V_{ECO}	7			V
Collector dark current	$V_{CE} = 25 \text{ V}, I_F = 0, E = 0$	I_{CEO}			100	nA

Switching Characteristics

Parameter	Test condition	Symbol	Min	Typ.	Max	Unit
Turn-on time	$V_S = 5 \text{ V}, I_C = 2 \text{ mA}, R_L = 100 \text{ } \Omega$ (see figure 1)	t_{on}		10.0		μs
Turn-off time	$V_S = 5 \text{ V}, I_C = 2 \text{ mA}, R_L = 100 \text{ } \Omega$ (see figure 1)	t_{off}		8.0		μs

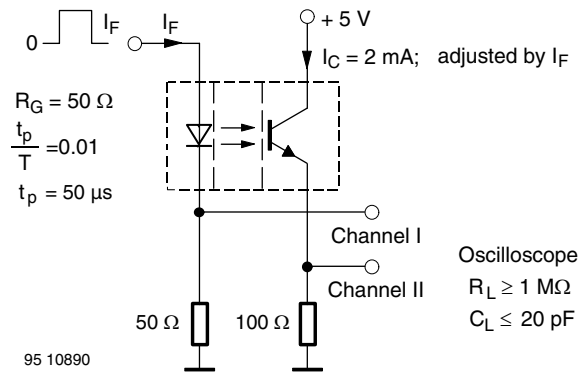

Figure 1. Test circuit for t_{on} and t_{off}

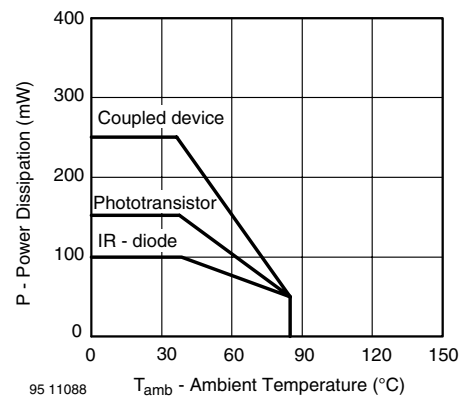

Figure 3. Power Dissipation Limit vs. Ambient Temperature

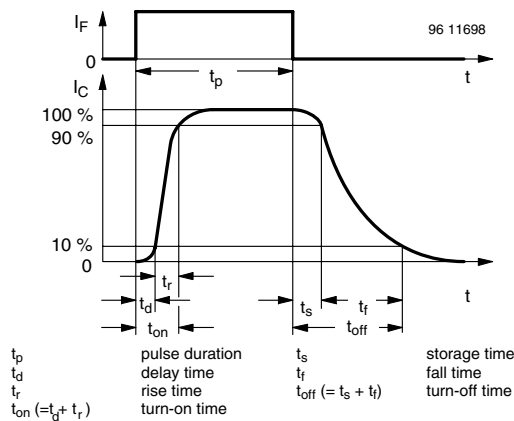

Figure 2. Switching Times

Typical Characteristics

$T_{amb} = 25\text{ }^{\circ}\text{C}$, unless otherwise specified

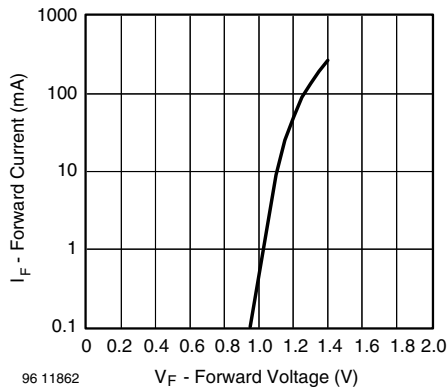

Figure 4. Forward Current vs. Forward Voltage

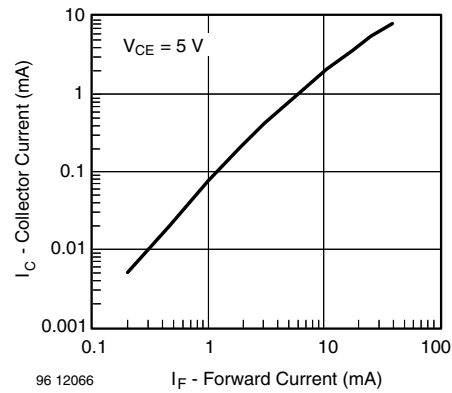

Figure 7. Collector Current vs. Forward Current

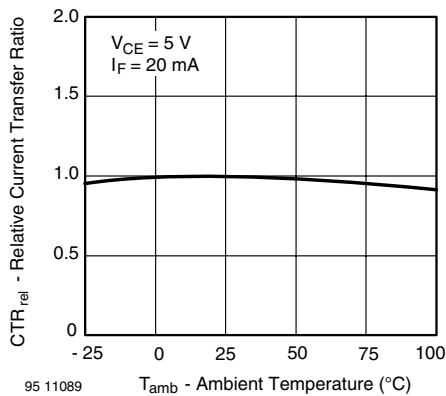

Figure 5. Relative Current Transfer Ratio vs. Ambient Temperature

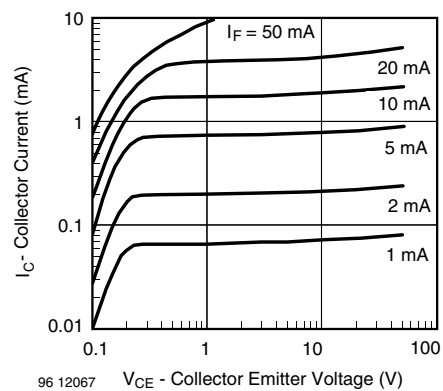

Figure 8. Collector Current vs. Collector Emitter Voltage

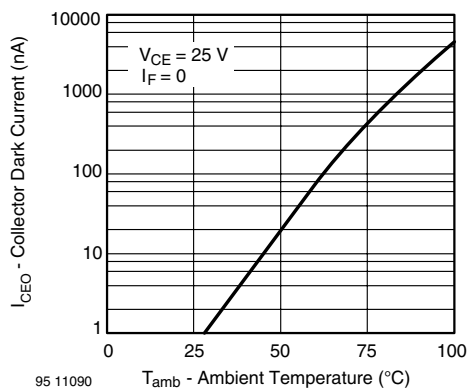

Figure 6. Collector Dark Current vs. Ambient Temperature

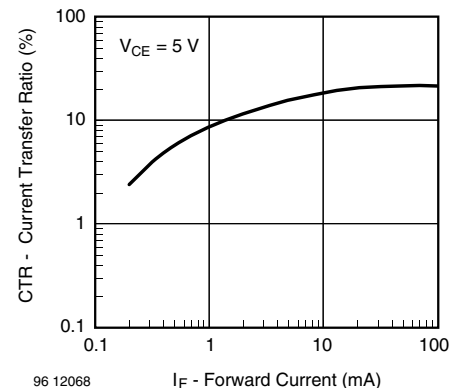

Figure 9. Current Transfer Ratio vs. Forward Current

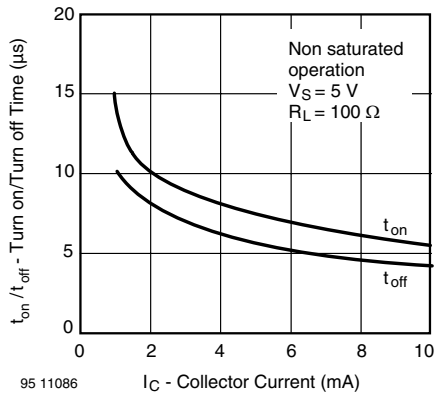

Figure 10. Turn on/off Time vs. Collector Current

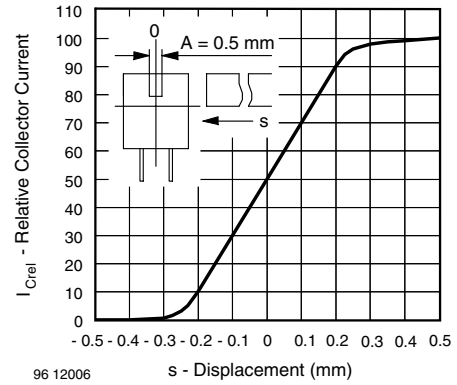

Figure 12. Relative Collector Current vs. Displacement

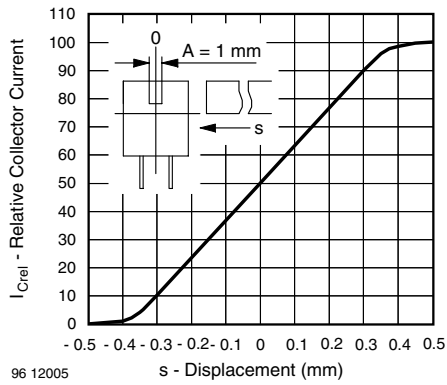

Figure 11. Relative Collector Current vs. Displacement

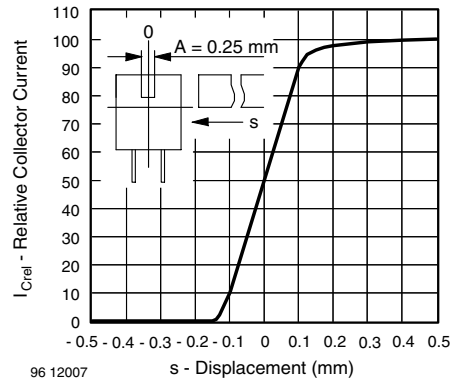
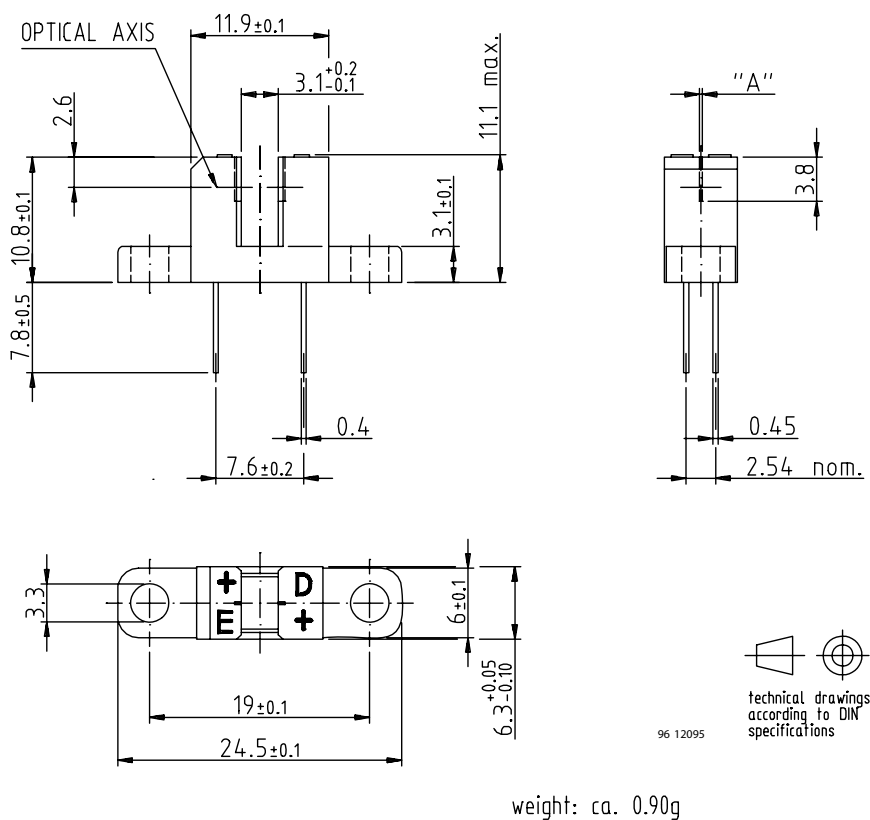
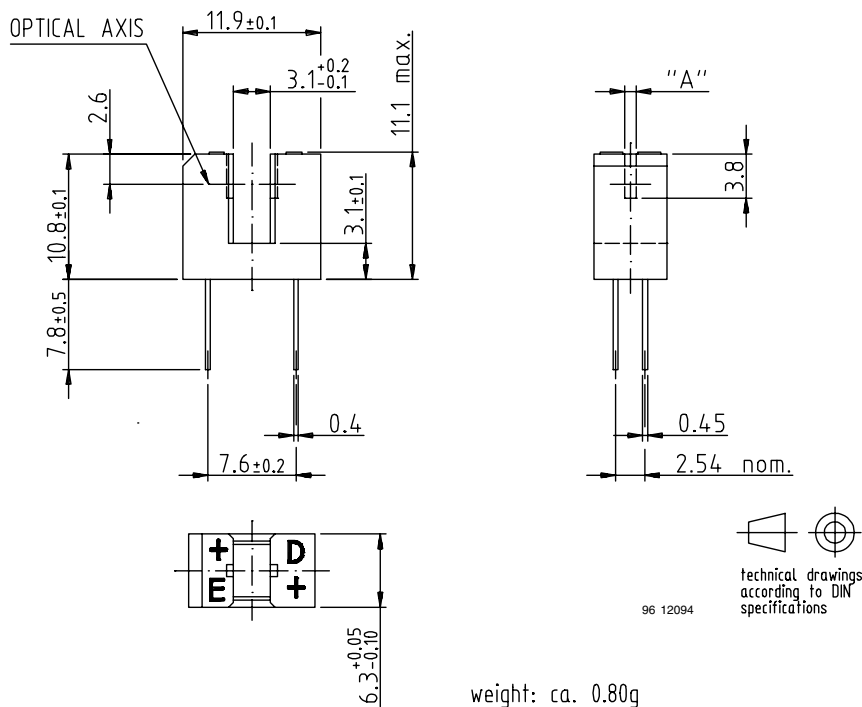

Figure 13. Relative Collector Current vs. Displacement

Package Dimensions in mm



Vishay Semiconductors

Ozone Depleting Substances Policy Statement

It is the policy of Vishay Semiconductor GmbH to

1. Meet all present and future national and international statutory requirements.
2. Regularly and continuously improve the performance of our products, processes, distribution and operating systems with respect to their impact on the health and safety of our employees and the public, as well as their impact on the environment.

It is particular concern to control or eliminate releases of those substances into the atmosphere which are known as ozone depleting substances (ODSs).

The Montreal Protocol (1987) and its London Amendments (1990) intend to severely restrict the use of ODSs and forbid their use within the next ten years. Various national and international initiatives are pressing for an earlier ban on these substances.

Vishay Semiconductor GmbH has been able to use its policy of continuous improvements to eliminate the use of ODSs listed in the following documents.

1. Annex A, B and list of transitional substances of the Montreal Protocol and the London Amendments respectively
2. Class I and II ozone depleting substances in the Clean Air Act Amendments of 1990 by the Environmental Protection Agency (EPA) in the USA
3. Council Decision 88/540/EEC and 91/690/EEC Annex A, B and C (transitional substances) respectively.

Vishay Semiconductor GmbH can certify that our semiconductors are not manufactured with ozone depleting substances and do not contain such substances.

We reserve the right to make changes to improve technical design
and may do so without further notice.

Parameters can vary in different applications. All operating parameters must be validated for each customer application by the customer. Should the buyer use Vishay Semiconductors products for any unintended or unauthorized application, the buyer shall indemnify Vishay Semiconductors against all claims, costs, damages, and expenses, arising out of, directly or indirectly, any claim of personal damage, injury or death associated with such unintended or unauthorized use.

Vishay Semiconductor GmbH, P.O.B. 3535, D-74025 Heilbronn, Germany



Notice

Specifications of the products displayed herein are subject to change without notice. Vishay Intertechnology, Inc., or anyone on its behalf, assumes no responsibility or liability for any errors or inaccuracies.

Information contained herein is intended to provide a product description only. No license, express or implied, by estoppel or otherwise, to any intellectual property rights is granted by this document. Except as provided in Vishay's terms and conditions of sale for such products, Vishay assumes no liability whatsoever, and disclaims any express or implied warranty, relating to sale and/or use of Vishay products including liability or warranties relating to fitness for a particular purpose, merchantability, or infringement of any patent, copyright, or other intellectual property right.

The products shown herein are not designed for use in medical, life-saving, or life-sustaining applications. Customers using or selling these products for use in such applications do so at their own risk and agree to fully indemnify Vishay for any damages resulting from such improper use or sale.