



HESTORE.HU

elektronikai alkatrész áruház

EN: This Datasheet is presented by the manufacturer.

Please visit our website for pricing and availability at www.hestore.hu.

LM3915

Dot/Bar Display Driver

General Description

The LM3915 is a monolithic integrated circuit that senses analog voltage levels and drives ten LEDs, LCDs or vacuum fluorescent displays, providing a logarithmic 3 dB/step analog display. One pin changes the display from a bar graph to a moving dot display. LED current drive is regulated and programmable, eliminating the need for current limiting resistors. The whole display system can operate from a single supply as low as 3V or as high as 25V.

The IC contains an adjustable voltage reference and an accurate ten-step voltage divider. The high-impedance input buffer accepts signals down to ground and up to within 1.5V of the positive supply. Further, it needs no protection against inputs of $\pm 35V$. The input buffer drives 10 individual comparators referenced to the precision divider. Accuracy is typically better than 1 dB.

The LM3915's 3 dB/step display is suited for signals with wide dynamic range, such as audio level, power, light intensity or vibration. Audio applications include average or peak level indicators, power meters and RF signal strength meters. Replacing conventional meters with an LED bar graph results in a faster responding, more rugged display with high visibility that retains the ease of interpretation of an analog display.

The LM3915 is extremely easy to apply. A 1.2V full-scale meter requires only one resistor in addition to the ten LEDs. One more resistor programs the full-scale anywhere from 1.2V to 12V independent of supply voltage. LED brightness is easily controlled with a single pot.

The LM3915 is very versatile. The outputs can drive LCDs, vacuum fluorescents and incandescent bulbs as well as LEDs of any color. Multiple devices can be cascaded for a dot or bar mode display with a range of 60 or 90 dB. LM3915s can also be cascaded with LM3914s for a linear/log display or with LM3916s for an extended-range VU meter.

Features

- 3 dB/step, 30 dB range
- Drives LEDs, LCDs, or vacuum fluorescents
- Bar or dot display mode externally selectable by user
- Expandable to displays of 90 dB
- Internal voltage reference from 1.2V to 12V
- Operates with single supply of 3V to 25V
- Inputs operate down to ground
- Output current programmable from 1 mA to 30 mA
- Input withstands $\pm 35V$ without damage or false outputs
- Outputs are current regulated, open collectors
- Directly drives TTL or CMOS
- The internal 10-step divider is floating and can be referenced to a wide range of voltages

The LM3915 is rated for operation from 0°C to +70°C. The LM3915N-1 is available in an 18-lead molded DIP package.

Typical Applications

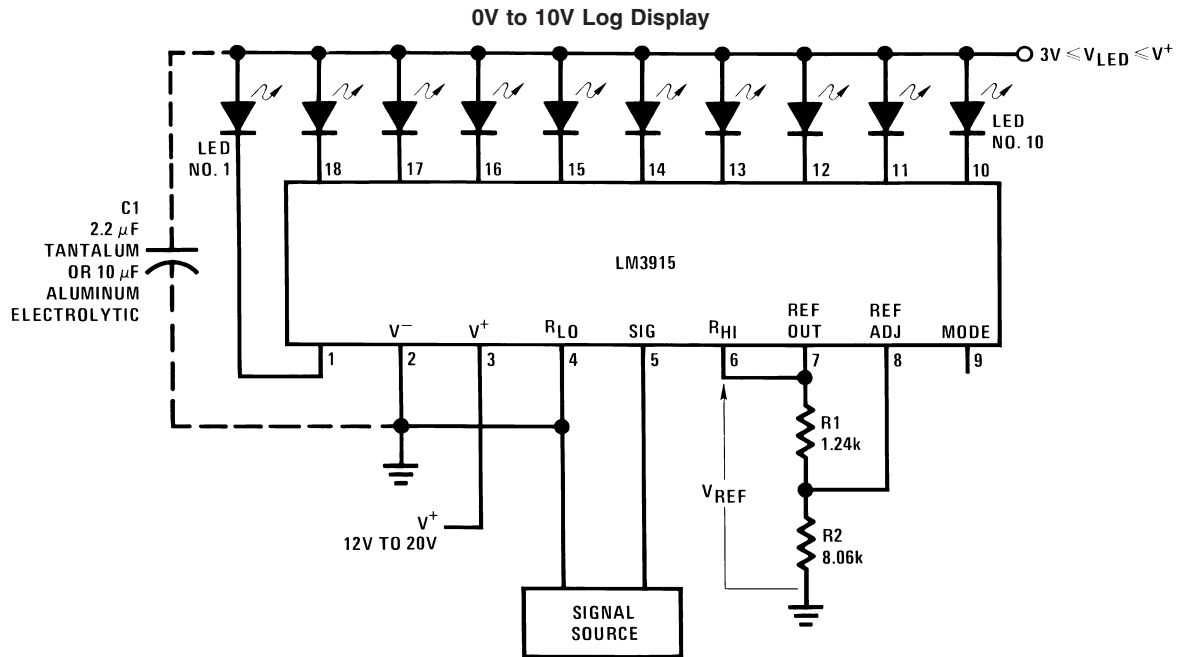

00510401

$$V_{REF} = 1.25V \left(1 + \frac{R_2}{R_1} \right) + R_2 \times 80 \mu A$$

$$I_{LED} = \frac{12.5V}{R_1} + \frac{V_{REF}}{2.2 k\Omega}$$

Absolute Maximum Ratings (Note 1)

If Military/Aerospace specified devices are required, please contact the National Semiconductor Sales Office/Distributors for availability and specifications.

Power Dissipation (Note 6)

Molded DIP(N)

1365 mW

Supply Voltage

25V

Voltage on Output Drivers

25V

Input Signal Overvoltage (Note 4)

±35V

Divider Voltage

-100 mV to V⁺

Reference Load Current

10 mA

Storage Temperature Range

-55°C to +150°C

Lead Temperature

(Soldering, 10 sec.)

260°C

Electrical Characteristics (Notes 2, 4)

Parameter	Conditions (Note 2)	Min	Typ	Max	Units
COMPARATOR					
Offset Voltage, Buffer and First Comparator	$0V \leq V_{RLO} = V_{RHI} \leq 12V$, $I_{LED} = 1 \text{ mA}$		3	10	mV
Offset Voltage, Buffer and Any Other Comparator	$0V \leq V_{RLO} = V_{RHI} \leq 12V$, $I_{LED} = 1 \text{ mA}$		3	15	mV
Gain ($\Delta I_{LED}/\Delta V_{IN}$)	$I_{L(REF)} = 2 \text{ mA}$, $I_{LED} = 10 \text{ mA}$	3	8		mA/mV
Input Bias Current (at Pin 5)	$0V \leq V_{IN} \leq (V^+ - 1.5V)$		25	100	nA
Input Signal Overvoltage	No Change in Display	-35		35	V
VOLTAGE-DIVIDER					
Divider Resistance	Total, Pin 6 to 4	16	28	36	kΩ
Relative Accuracy (Input Change Between Any Two Threshold Points)	(Note 3)	2.0	3.0	4.0	dB
Absolute Accuracy at Each Threshold Point	(Note 3)				
	$V_{IN} = -3, -6 \text{ dB}$	-0.5		+0.5	dB
	$V_{IN} = -9 \text{ dB}$	-0.5		+0.65	dB
	$V_{IN} = -12, -15, -18 \text{ dB}$	-0.5		+1.0	dB
	$V_{IH} = -21, -24, -27 \text{ dB}$	-0.5		+1.5	dB
VOLTAGE REFERENCE					
Output Voltage	$0.1 \text{ mA} \leq I_{L(REF)} \leq 4 \text{ mA}$, $V^+ = V_{LED} = 5V$	1.2	1.28	1.34	V
Line Regulation	$3V \leq V^+ \leq 18V$		0.01	0.03	%/V
Load Regulation	$0.1 \text{ mA} \leq I_{L(REF)} \leq 4 \text{ mA}$, $V^+ = V_{LED} = 5V$		0.4	2	%
Output Voltage Change with Temperature	$0^\circ\text{C} \leq T_A \leq +70^\circ\text{C}$, $I_{L(REF)} = 1 \text{ mA}$, $V^+ = V_{LED} = 5V$		1		%
Adjust Pin Current			75	120	μA
OUTPUT DRIVERS					
LED Current	$V^+ = V_{LED} = 5V$, $I_{L(REF)} = 1 \text{ mA}$	7	10	13	mA
LED Current Difference (Between Largest and Smallest LED Currents)	$V_{LED} = 5V$, $I_{LED} = 2 \text{ mA}$		0.12	0.4	mA
	$V_{LED} = 5V$, $I_{LED} = 20 \text{ mA}$		1.2	3	
LED Current Regulation	$2V \leq V_{LED} \leq 17V$, $I_{LED} = 2 \text{ mA}$, $I_{LED} = 20 \text{ mA}$		0.1	0.25	mA
			1	3	
Dropout Voltage	$I_{LED(ON)} = 20 \text{ mA}$, @ $V_{LED} = 5V$, $\Delta I_{LED} = 2 \text{ mA}$			1.5	V
Saturation Voltage	$I_{LED} = 2.0 \text{ mA}$, $I_{L(REF)} = 0.4 \text{ mA}$		0.15	0.4	V
Output Leakage, Each Collector	(Bar Mode) (Note 5)		0.1	10	μA
Output Leakage Pins 10–18 Pin 1	(Dot Mode) (Note 5)		0.1	10	μA
		60	150	450	μA

Electrical Characteristics (Notes 2, 4) (Continued)

Parameter	Conditions (Note 2)	Min	Typ	Max	Units
SUPPLY CURRENT					
Standby Supply Current (All Outputs Off)	$V^+ = +5V, I_{L(REF)} = 0.2 \text{ mA}$		2.4	4.2	mA
	$V^+ = +20V, I_{L(REF)} = 1.0 \text{ mA}$		6.1	9.2	mA

Note 1: Absolute Maximum Ratings indicate limits beyond which damage to the device may occur. Operating Ratings indicate conditions for which the device is functional, but do not guarantee specific performance limits. Electrical Characteristics state DC and AC electrical specifications under particular test conditions which guarantee specific performance limits. This assumes that the device is within the Operating Ratings. Specifications are not guaranteed for parameters where no limit is given, however, the typical value is a good indication of device performance.

Note 2: Unless otherwise stated, all specifications apply with the following conditions:

$$3 V_{DC} \leq V^+ \leq 20 V_{DC} \quad -0.015V \leq V_{RLO} \leq 12 V_{DC} \quad T_A = 25^\circ\text{C}, I_{L(REF)} = 0.2 \text{ mA}, \text{ pin 9 connected to pin 3 (bar mode).}$$

$$3 V_{DC} \leq V_{LED} \leq V^+ \quad V_{REF}, V_{RHI}, V_{RLO} \leq (V^+ - 1.5V) \quad \text{For higher power dissipations, pulse testing is used.}$$

$$-0.015V \leq V_{RHI} \leq 12 V_{DC} \quad 0V \leq V_{IN} \leq V^+ - 1.5V$$

Note 3: Accuracy is measured referred to 0 dB = + 10.000 V_{DC} at pin 5, with + 10.000 V_{DC} at pin 6, and 0.000 V_{DC} at pin 4. At lower full scale voltages, buffer and comparator offset voltage may add significant error. See table for threshold voltages.

Note 4: Pin 5 input current must be limited to $\pm 3 \text{ mA}$. The addition of a 39k resistor in series with pin 5 allows $\pm 100V$ signals without damage.

Note 5: Bar mode results when pin 9 is within 20 mV of V^+ . Dot mode results when pin 9 is pulled at least 200 mV below V^+ . LED #10 (pin 10 output current) is disabled if pin 9 is pulled 0.9V or more below V_{LED} .

Note 6: The maximum junction temperature of the LM3915 is 100°C . Devices must be derated for operation at elevated temperatures. Junction to ambient thermal resistance is 55°C/W for the molded DIP (N package).

Threshold Voltage (Note 3)

Output	dB	Min	Typ	Max	Output	dB	Min	Typ	Max
1	-27	0.422	0.447	0.531	6	-12	2.372	2.512	2.819
2	-24	0.596	0.631	0.750	7	-9	3.350	3.548	3.825
3	-21	0.841	0.891	1.059	8	-6	4.732	5.012	5.309
4	-18	1.189	1.259	1.413	9	-3	6.683	7.079	7.498
5	-15	1.679	1.778	1.995	10	0	9.985	10	10.015

Typical Performance Characteristics

Supply Current vs Temperature

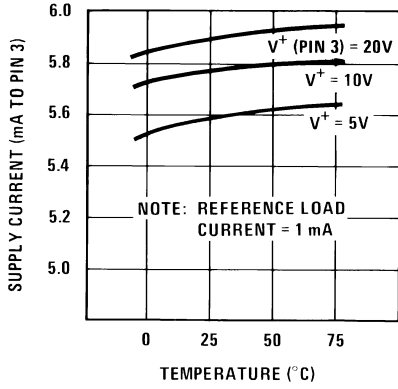

00510434

Operating Input Bias Current vs Temperature

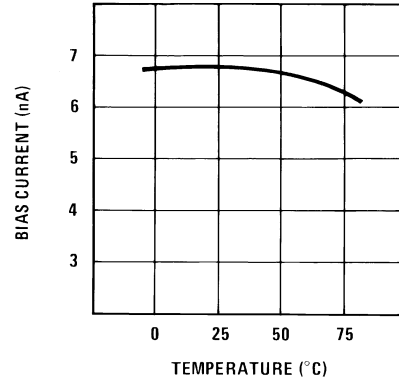

00510435

Reference Voltage vs Temperature

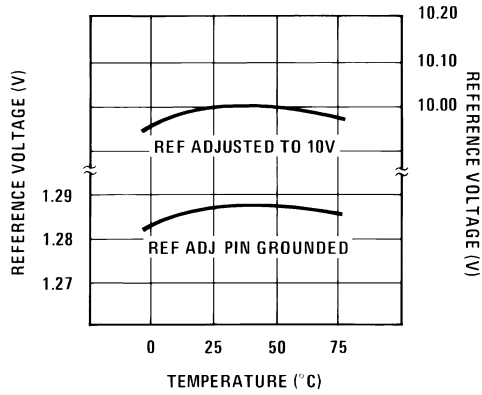

00510436

Reference Adjust Pin Current vs Temperature

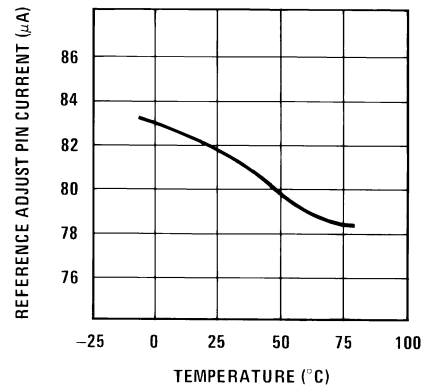

00510437

LED Current-Regulation Dropout

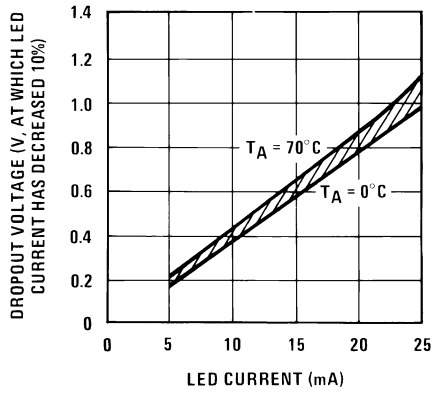

00510438

LED Driver Saturation Voltage

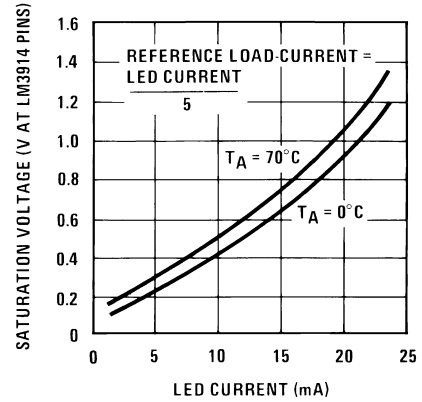

00510439

Typical Performance Characteristics (Continued)

Input Current Beyond Signal Range (Pin 5)

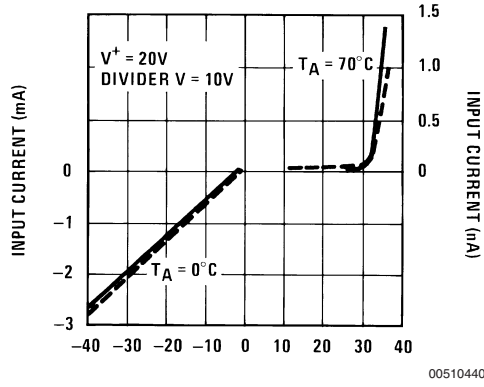

LED Current vs Reference Loading

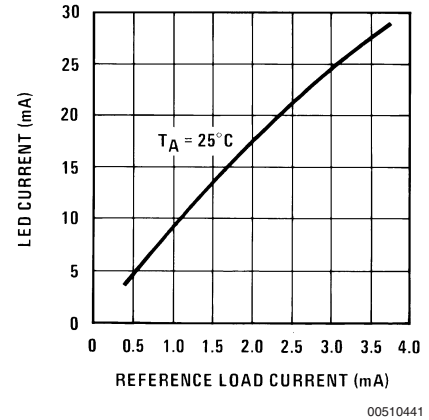

LED Driver Current Regulation

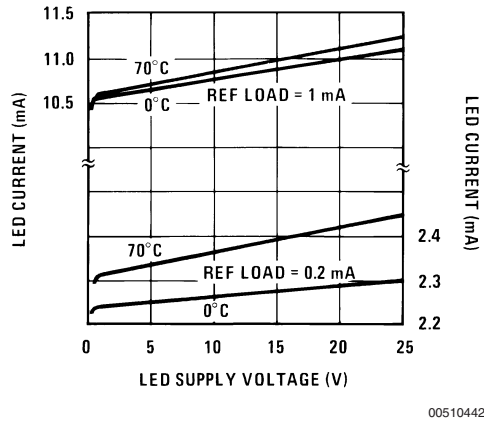

Total Divider Resistance vs Temperature

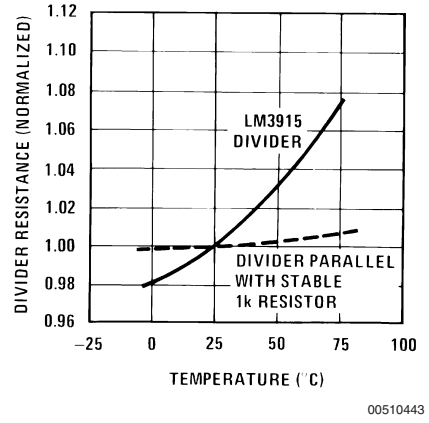

Common-Mode Limits

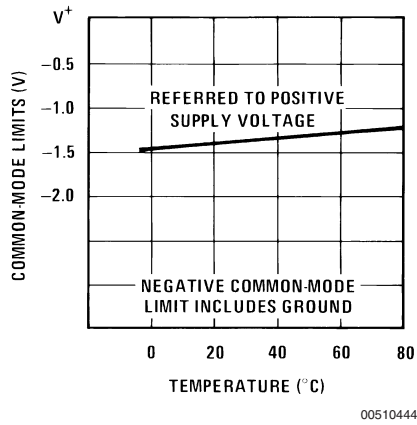

Output Characteristics

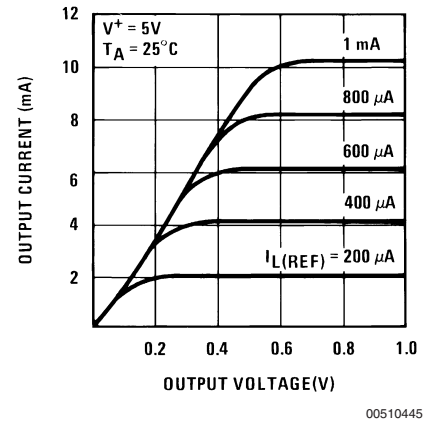

Block Diagram (Showing Simplest Application)

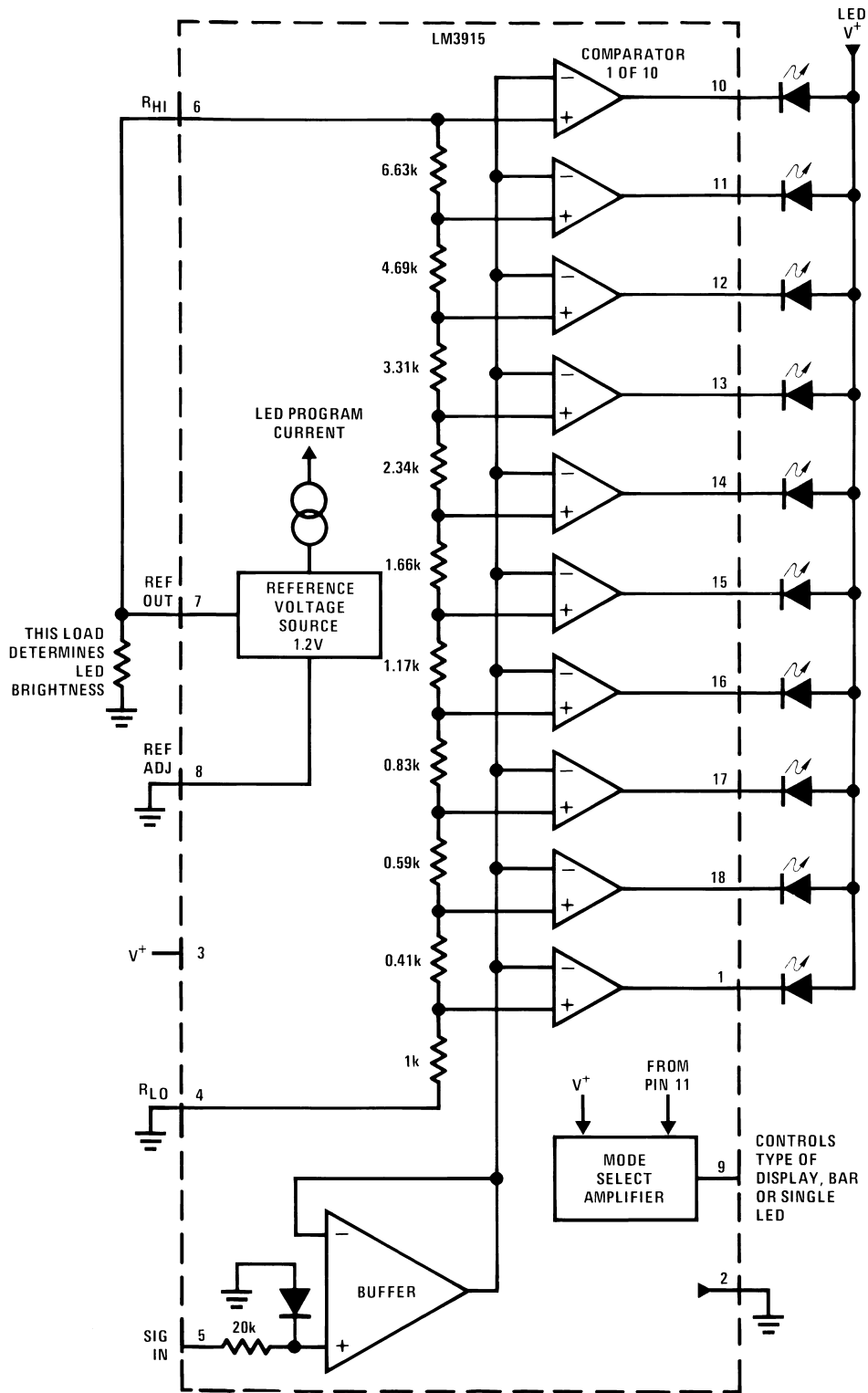

00510404

Functional Description

The simplified LM3915 block diagram is included to give the general idea of the circuit's operation. A high input impedance buffer operates with signals from ground to 12V, and is protected against reverse and overvoltage signals. The signal is then applied to a series of 10 comparators; each of which is biased to a different comparison level by the resistor string.

In the example illustrated, the resistor string is connected to the internal 1.25V reference voltage. In this case, for each 3 dB that the input signal increases, a comparator will switch on another indicating LED. This resistor divider can be connected between any 2 voltages, providing that they are at least 1.5V below V^+ and no lower than V^- .

INTERNAL VOLTAGE REFERENCE

The reference is designed to be adjustable and develops a nominal 1.25V between the REF OUT (pin 7) and REF ADJ (pin 8) terminals. The reference voltage is impressed across program resistor R1 and, since the voltage is constant, a constant current I_1 then flows through the output set resistor R2 giving an output voltage of:

$$V_{OUT} = V_{REF} \left(1 + \frac{R_2}{R_1} \right) + I_{ADJ} R_2$$

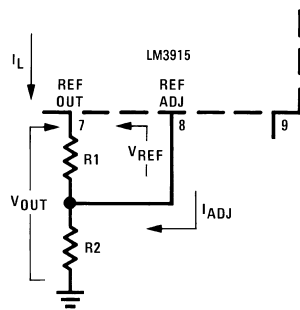

00510405

Since the 120 μ A current (max) from the adjust terminal represents an error term, the reference was designed to minimize changes of this current with V^+ and load changes. For correct operation, reference load current should be between 80 μ A and 5 mA. Load capacitance should be less than 0.05 μ F.

CURRENT PROGRAMMING

A feature not completely illustrated by the block diagram is the LED brightness control. The current drawn out of the reference voltage pin (pin 7) determines LED current. Approximately 10 times this current will be drawn through each lighted LED, and this current will be relatively constant despite supply voltage and temperature changes. Current drawn by the internal 10-resistor divider, as well as by the external current and voltage-setting divider should be included in calculating LED drive current. The ability to modulate LED brightness with time, or in proportion to input voltage and other signals can lead to a number of novel displays or ways of indicating input overvoltages, alarms, etc.

The LM3915 outputs are current-limited NPN transistors as shown below. An internal feedback loop regulates the transistor drive. Output current is held at about 10 times the reference load current, independent of output voltage and processing variables, as long as the transistor is not saturated.

LM3915 Output Circuit

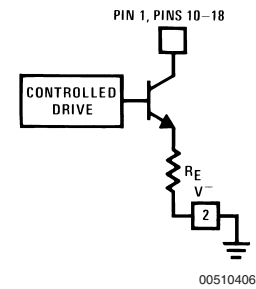

00510406

Outputs may be run in saturation with no adverse effects, making it possible to directly drive logic. The effective saturation resistance of the output transistors, equal to R_E plus the transistors' collector resistance, is about 50 Ω . It's also possible to drive LEDs from rectified AC with no filtering. To avoid oscillations, the LED supply should be bypassed with a 2.2 μ F tantalum or 10 μ F aluminum electrolytic capacitor.

MODE PIN USE

Pin 9, the Mode Select input, permits chaining of multiple LM3915s, and controls bar or dot mode operation. The following tabulation shows the basic ways of using this input. Other more complex uses will be illustrated in the applications.

Bar Graph Display: Wire Mode Select (pin 9) *directly* to pin 3 (V^+ pin).

Dot Display, Single LM3915 Driver: Leave the Mode Select pin open circuit.

Dot Display, 20 or More LEDs: Connect pin 9 of the *first* driver in the series (i.e., the one with the lowest input voltage comparison points) to pin 1 of the next higher LM3915 driver. Continue connecting pin 9 of lower input drivers to pin 1 of higher input drivers for 30 or more LED displays. The last LM3915 driver in the chain will have pin 9 left open. All previous drivers should have a 20k resistor in parallel with LED #9 (pin 11 to V_{LED}).

Mode Pin Functional Description

This pin actually performs two functions. Refer to the simplified block diagram below.

Block Diagram of Mode Pin Function

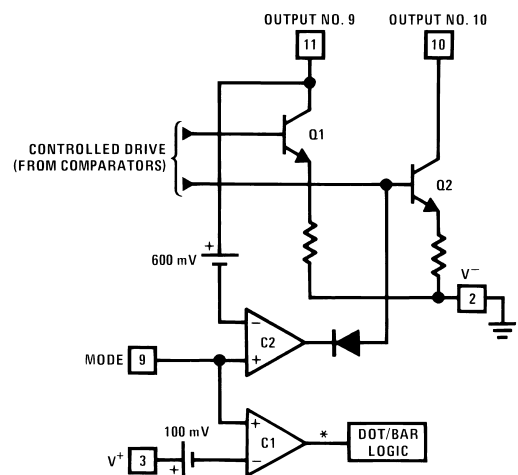

00510407

*High for bar

Mode Pin Functional Description

(Continued)

DOT OR BAR MODE SELECTION

The voltage at pin 9 is sensed by comparator C1, nominally referenced to ($V^+ - 100$ mV). The chip is in bar mode when pin 9 is above this level; otherwise it's in dot mode. The comparator is designed so that pin 9 can be left open circuit for dot mode.

Taking into account comparator gain and variation in the 100 mV reference level, pin 9 should be no more than 20 mV below V^+ for bar mode and more than 200 mV below V^+ (or open circuit) for dot mode. In most applications, pin 9 is either open (dot mode) or tied to V^+ (bar mode). In bar mode, pin 9 should be connected directly to pin 3. Large currents drawn from the power supply (LED current, for example) should not share this path so that large IR drops are avoided.

DOT MODE CARRY

In order for the display to make sense when multiple LM3915s are cascaded in dot mode, special circuitry has been included to shut off LED #10 of the first device when LED #1 of the second device comes on. The connection for cascading in dot mode has already been described and is depicted below.

As long as the input signal voltage is below the threshold of the second LM3915, LED #11 is off. Pin 9 of LM3915 #1 thus sees effectively an open circuit so the chip is in dot mode. As soon as the input voltage reaches the threshold of LED #11, pin 9 of LM3915 #1 is pulled an LED drop (1.5V or more) below V_{LED} . This condition is sensed by comparator C2, referenced 600 mV below V_{LED} . This forces the output of C2 low, which shuts off output transistor Q2, extinguishing LED #10.

V_{LED} is sensed via the 20k resistor connected to pin 11. The very small current (less than 100 μ A) that is diverted from LED #9 does not noticeably affect its intensity.

An auxiliary current source at pin 1 keeps at least 100 μ A flowing through LED #11 even if the input voltage rises high enough to extinguish the LED. This ensures that pin 9 of LM3915 #1 is held low enough to force LED #10 off when *any* higher LED is illuminated. While 100 μ A does not normally produce significant LED illumination, it may be noticeable when using high-efficiency LEDs in a dark environment. If this is bothersome, the simple cure is to shunt LED #11 with a 10k resistor. The 1V IR drop is more than the 900 mV

worst case required to hold off LED #10 yet small enough that LED #11 does not conduct significantly.

OTHER DEVICE CHARACTERISTICS

The LM3915 is relatively low-powered itself, and since any number of LEDs can be powered from about 3V, it is a very efficient display driver. Typical standby supply current (all LEDs OFF) is 1.6 mA. However, any reference loading adds 4 times that current drain to the V^+ (pin 3) supply input. For example, an LM3916 with a 1 mA reference pin load (1.3k) would supply almost 10 mA to every LED while drawing only 10 mA from its V^+ pin supply. At full-scale, the IC is typically drawing less than 10% of the current supplied to the display.

The display driver does not have built-in hysteresis so that the display does not jump instantly from one LED to the next. Under rapidly changing signal conditions, this cuts down high frequency noise and often an annoying flicker. An "overlap" is built in so that at no time are all segments completely off in the dot mode. Generally 1 LED fades in while the other fades out over a mV or more of range. The change may be much more rapid between LED #10 of one device and LED #1 of a *second* device "chained" to the first.

Application Hints

The most difficult problem occurs when large LED currents are being drawn, especially in bar graph mode. These currents flowing out of the ground pin cause voltage drops in external wiring, and thus errors and oscillations. Bringing the return wires from signal sources, reference ground and bottom of the resistor string to a single point very near pin 2 is the best solution.

Long wires from V_{LED} to LED anode common can cause oscillations. Depending on the severity of the problem 0.05 μ F to 2.2 μ F decoupling capacitors from LED anode common to pin 2 will damp the circuit. If LED anode line wiring is inaccessible, often similar decoupling from pin 1 to pin 2 will be sufficient.

If LED turn ON seems slow (bar mode) or several LEDs light (dot mode), oscillation or excessive noise is usually the problem. In cases where proper wiring and bypassing fail to stop oscillations, V^+ voltage at pin 3 is usually below suggested limits. Expanded scale meter applications may have one or both ends of the internal voltage divider terminated at relatively high value resistors. These high-impedance ends should be bypassed to pin 2 with at least a 0.001 μ F capacitor, or up to 0.1 μ F in noisy environments.

Cascading LM3915s in Dot Mode

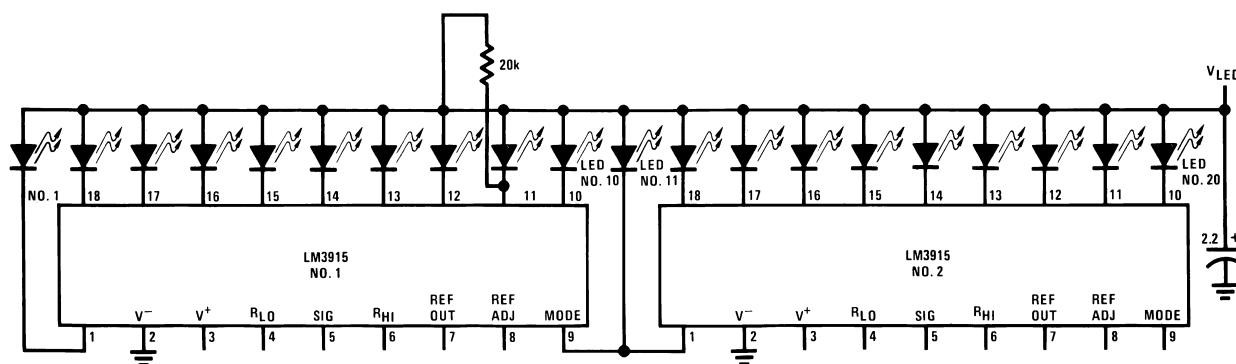

00510408

Application Hints (Continued)

Power dissipation, especially in bar mode should be given consideration. For example, with a 5V supply and all LEDs programmed to 20 mA the driver will dissipate over 600 mW. In this case a 7.5Ω resistor in series with the LED supply will cut device heating in half. The negative end of the resistor should be bypassed with a $2.2\ \mu\text{F}$ solid tantalum capacitor to pin 2.

TIPS ON RECTIFIER CIRCUITS

The simplest way to display an AC signal using the LM3915 is to apply it right to pin 5 unrectified. Since the LED illuminated represents the instantaneous value of the AC waveform, one can readily discern both peak and average values of audio signals in this manner. The LM3915 will respond to positive half-cycles only but will not be damaged by signals up to $\pm 35\text{V}$ (or up to $\pm 100\text{V}$ if a 39k resistor is in series with the input). It's recommended to use dot mode and to run the LEDs at 30 mA for high enough average intensity.

True average or peak detection requires rectification. If an LM3915 is set up with 10V full scale across its voltage divider, the turn-on point for the first LED is only 450 mV. A simple silicon diode rectifier won't work well at the low end due to the 600 mV diode threshold. The half-wave peak detector in *Figure 1* uses a PNP emitter-follower in front of the diode. Now, the transistor's base-emitter voltage cancels out the diode offset, within about 100 mV. This approach is usually satisfactory when a single LM3915 is used for a 30 dB display.

Display circuits using two or more LM3915s for a dynamic range of 60 dB or greater require more accurate detection. In the precision half-wave rectifier of *Figure 2* the effective diode offset is reduced by a factor equal to the open-loop gain of the op amp. Filter capacitor C2 charges through R3 and discharges through R2 and R3, so that appropriate selection of these values results in either a peak or an average detector. The circuit has a gain equal to $R2/R1$.

It's best to capacitively couple the input. Audio sources frequently have a small DC offset that can cause significant error at the low end of the log display. Op amps that slew quickly, such as the LF351, LF353, or LF356, are needed to faithfully respond to sudden transients. It may be necessary to trim out the op amp DC offset voltage to accurately cover a 60 dB range. Best results are obtained if the circuit is adjusted for the correct output when a low-level AC signal (10 mV to 20 mV) is applied, rather than adjusting for zero output with zero input.

For precision full-wave averaging use the circuit in *Figure 3*. Using 1% resistors for R1 through R4, gain for positive and negative signal differs by only 0.5 dB worst case. Substituting 5% resistors increases this to 2 dB worst case. (A 2 dB

gain difference means that the display may have a ± 1 dB error when the input is a nonsymmetrical transient). The averaging time constant is $R5-C2$. A simple modification results in the precision full-wave detector of *Figure 4*. Since the filter capacitor is not buffered, this circuit can drive only high impedance loads such as the input of an LM3915.

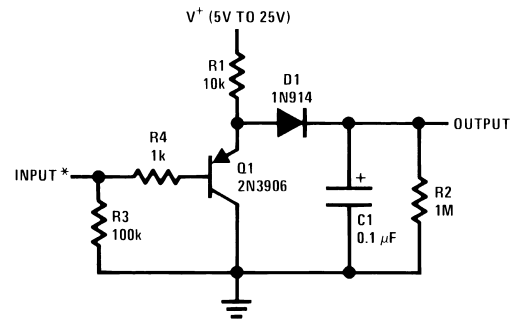

*DC Couple

00510409

FIGURE 1. Half-Wave Peak Detector

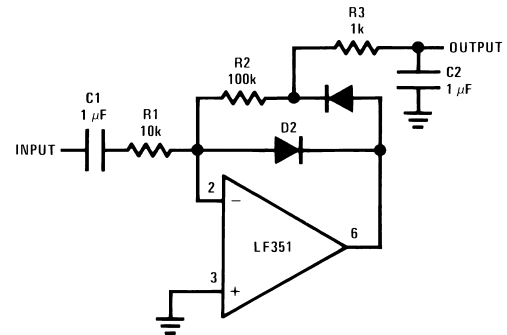

D1, D2: 1N914 or 1N4148

00510410

	Average	Peak
R2	1k	100k
R3	100k	1k

$R1 = R2$ for $A_V = 1$
 $R1 = R2/R10$ for $A_V = 10$
 $C1 = 10/R1$

FIGURE 2. Precision Half-Wave Rectifier

Application Hints (Continued)

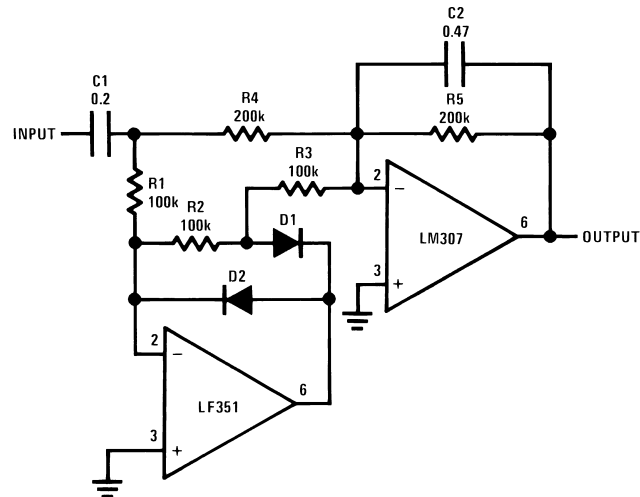

00510411

D1, D2: 1N914 or 1N4148

FIGURE 3. Precision Full-Wave Average Detector

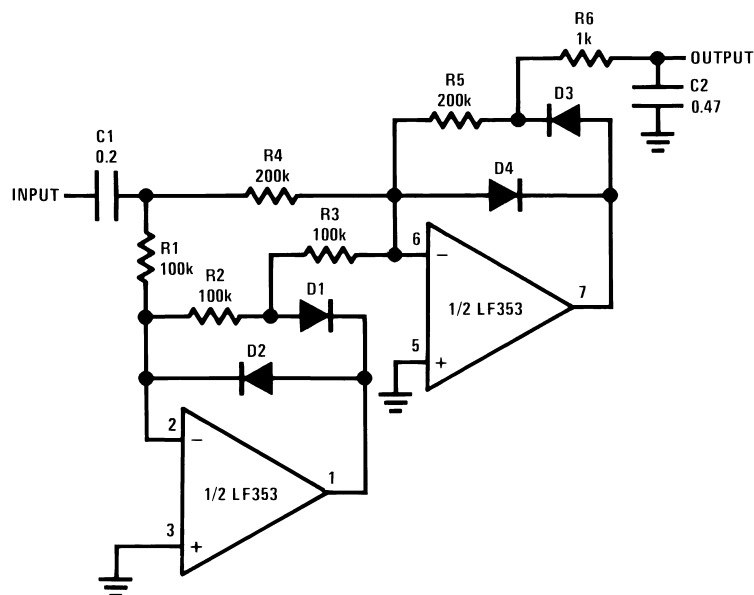

00510412

D1, D2, D3, D4: 1N914 or 1N4148

FIGURE 4. Precision Full-Wave Peak Detector

CASCADING THE LM3915

To display signals of 60 dB or 90 dB dynamic range, multiple LM3915s can be easily cascaded. Alternatively, it is possible to cascade an LM3915 with LM3914s for a log/linear display or with an LM3916 to get an extended range VU meter.

A simple, low cost approach to cascading two LM3915s is to set the reference voltages of the two chips 30 dB apart as in *Figure 5*. Potentiometer R1 is used to adjust the full scale voltage of LM3915 #1 to 316 mV nominally while the second IC's reference is set at 10V by R4. The drawback of this method is that the threshold of LED #1 is only 14 mV and,

since the LM3915 can have an offset voltage as high as 10 mV, large errors can occur. This technique is not recommended for 60 dB displays requiring good accuracy at the first few display thresholds.

A better approach shown in *Figure 6* is to keep the reference at 10V for both LM3915s and amplify the input signal to the lower LM3915 by 30 dB. Since two 1% resistors can set the amplifier gain within ± 0.2 dB, a gain trim is unnecessary. However, an op amp offset voltage of 5 mV will shift the first LED threshold as much as 4 dB, so that an offset trim may be required. Note that a single adjustment can null out offset

Application Hints (Continued)

in both the precision rectifier and the 30 dB gain stage.

Alternatively, instead of amplifying, input signals of sufficient amplitude can be fed directly to the lower LM3915 and *attenuated* by 30 dB to drive the second LM3915.

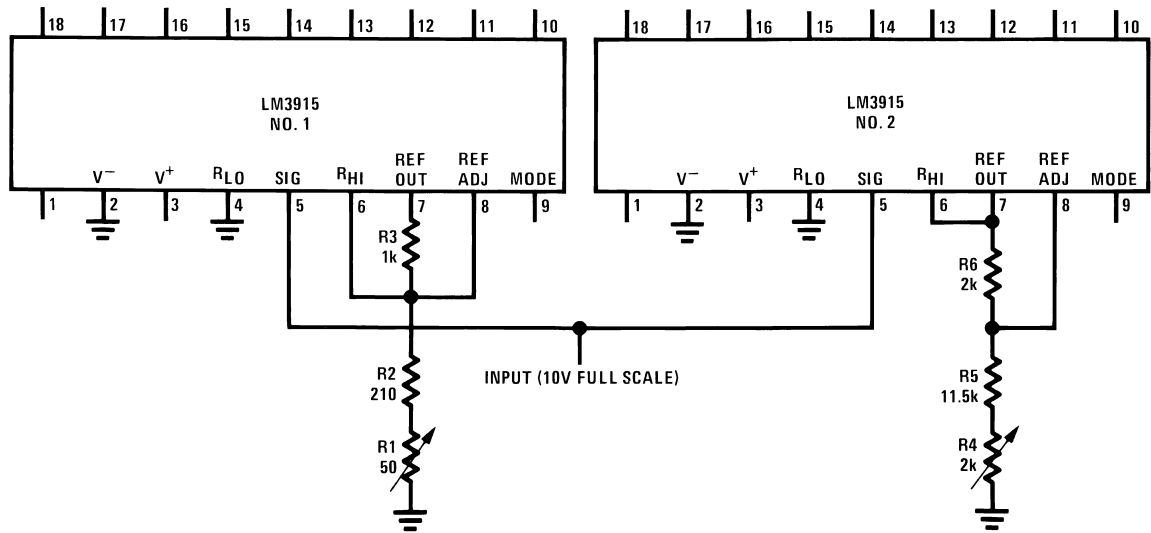

00510413

FIGURE 5. Low Cost Circuit for 60 dB Display

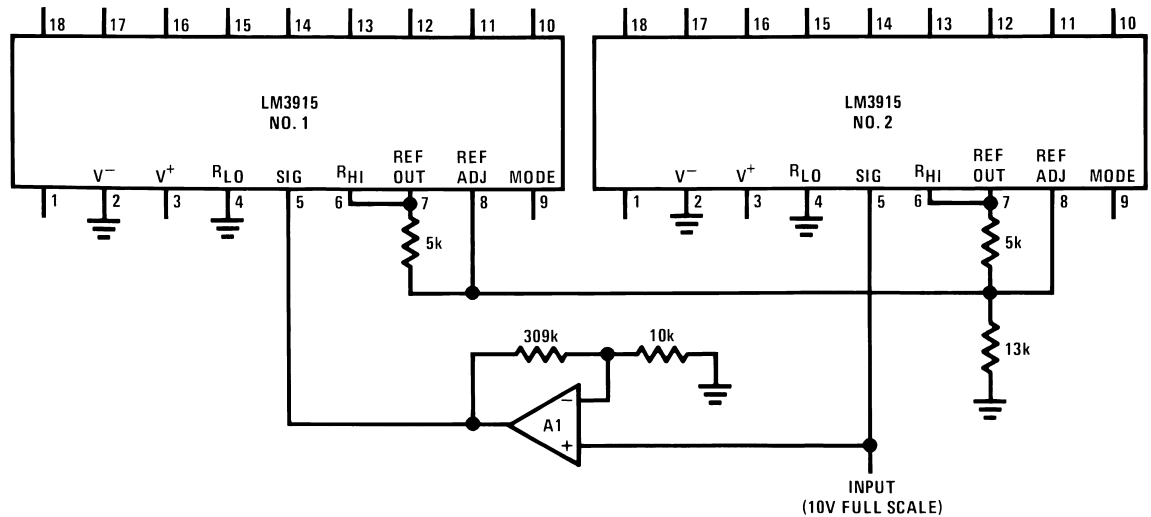

00510414

FIGURE 6. Improved Circuit for 60 dB Display

To extend this approach to get a 90 dB display, another 30 dB of amplification must be placed in the signal path ahead of the lowest LM3915. Extreme care is required as the lowest LM3915 displays input signals down to 0.5 mV! Several offset nulls may be required. High currents should not share the same path as the low level signal. Also power line wiring should be kept away from signal lines.

TIPS ON REFERENCE VOLTAGE AND LED CURRENT PROGRAMMING

Single LM3915

The equations in *Figure 7* illustrate how to choose resistor values to set reference voltage for the simple case where no LED intensity adjustment is required. A LED current of 10 mA to 20 mA generally produces adequate illumination. Having 10V full-scale across the internal voltage divider gives best accuracy by keeping signal level high relative to the offset voltage of the internal comparators. However, this causes 450 μ A to flow from pin 7 into the divider which means that

Application Hints (Continued)

the LED current will be at least 5 mA. R1 will typically be between 1 k Ω and 2 k Ω . To trim the reference voltage, vary R2.

The circuit in *Figure 8* shows how to add a LED intensity control which can vary LED current from 9 mA to 28 mA. The reference adjustment has some effect on LED intensity but the reverse is not true.

Multiple LM3915s

Figure 9 shows how to obtain a common reference trim and intensity control for two LM3915s. The two ICs may be connected in cascade for a 60 dB display or may be handling

separate channels for stereo. This technique can be extended for larger numbers of LM3915s by varying the values of R1, R2 and R3 in inverse proportion to the number of devices tied in. The ICs' internal references track within 100 mV so that worst case error from chip to chip is only 0.1 dB for $V_{REF} = 10V$.

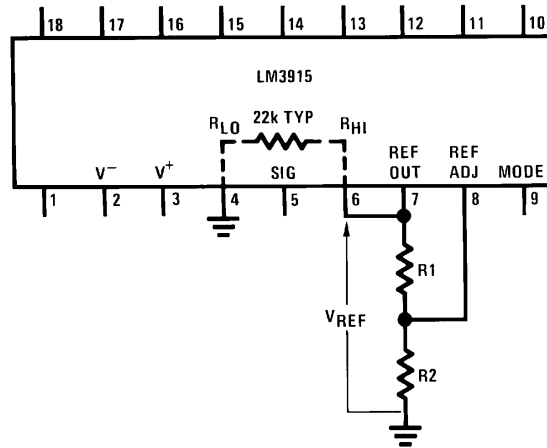

00510415

Adjust R2 to vary V_{REF}

$$\text{Pick } R1 = \frac{12.5V}{I_{LED} - V_{REF}/2.2 \text{ k}\Omega}$$

$$\text{Pick } R2 = \frac{(V_{REF} - 1.25V)}{(1.25V/R1) + 0.08 \text{ mA}}$$

FIGURE 7. Design Equations for Fixed LED Intensity

Application Hints (Continued)

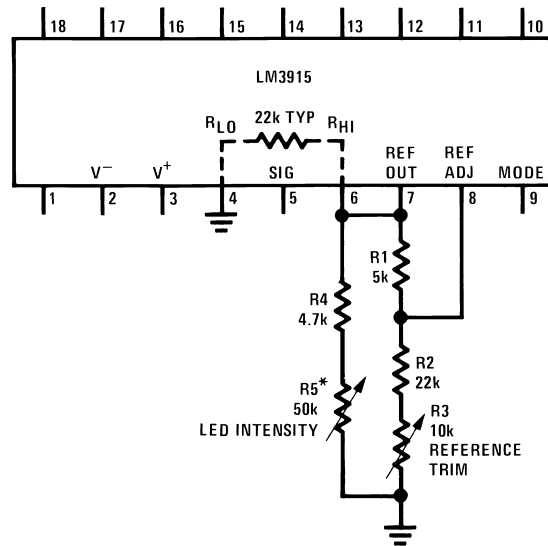

00510416

*9 mA < I_{LED} < 28 mA @ $V_{REF} = 10V$

FIGURE 8. Varying LED Intensity

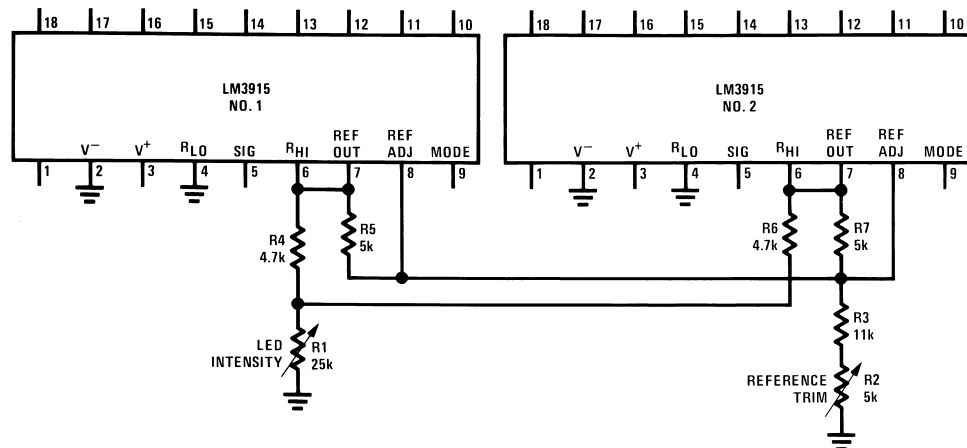

00510417

FIGURE 9. Independent Adjustment of Reference Voltage and LED Intensity for Multiple LM3915s

The scheme in *Figure 10* is useful when the reference and LED intensity must be adjusted independently over a wide range. The R_{HI} voltage can be adjusted from 1.2V to 10V with no effect on LED current. Since the internal divider here does not load down the reference, minimum LED current is much lower. At the minimum recommended reference load of 80 μ A, LED current is about 0.8 mA. The resistor values shown give a LED current range from 1.5 mA to 20 mA.

At the low end of the intensity adjustment, the voltage drop across the 510 Ω current-sharing resistors is so small that chip to chip variation in reference voltage may yield a visible variation in LED intensity. The optional approach shown of connecting the bottom end of the intensity control pot to a negative supply overcomes this problem by allowing a larger voltage drop across the (larger) current-sharing resistors.

Other Applications

For increased resolution, it's possible to obtain a display with a smooth transition between LEDs. This is accomplished by varying the reference level at pin 6 by 3 dBp-p as shown in *Figure 11*. The signal can be a triangle, sawtooth or sine wave from 60 Hz to 1 kHz. The display can be run in either dot or bar mode.

When an exponentially decaying RC discharge waveform is applied to pin 5, the LM3915's outputs will switch at equal intervals. This makes a simple timer or sequencer. Each time interval is equal to $RC/3$. The output may be used to drive logic, opto-couplers, relays or PNP transistors, for example.

Typical Applications

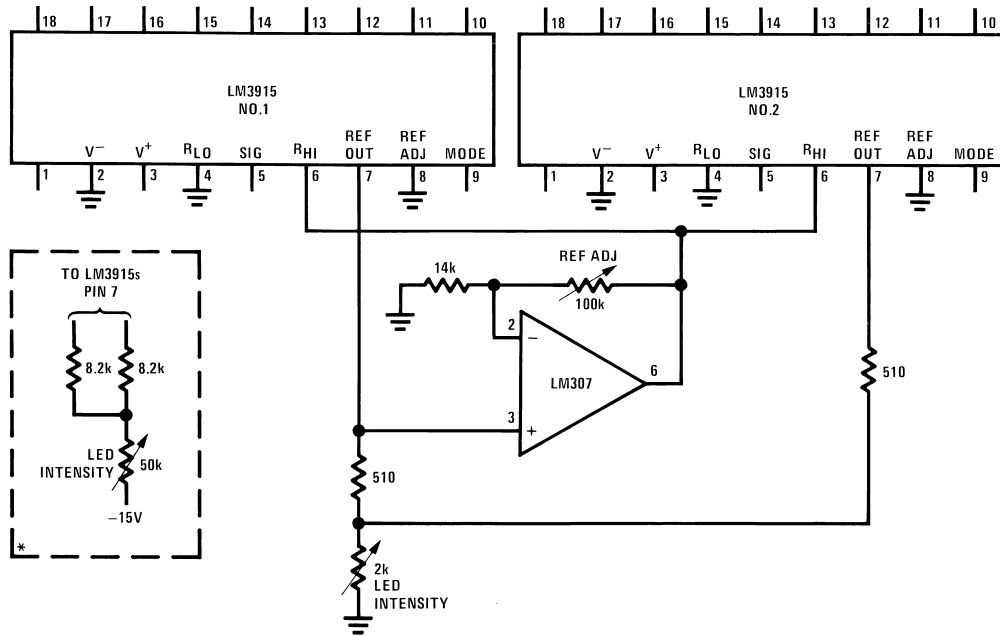

00510418

*Optional circuit for improved intensity matching at low currents.
See text.

FIGURE 10. Wide-Range Adjustment of Reference Voltage and LED Intensity for Multiple LM3915s

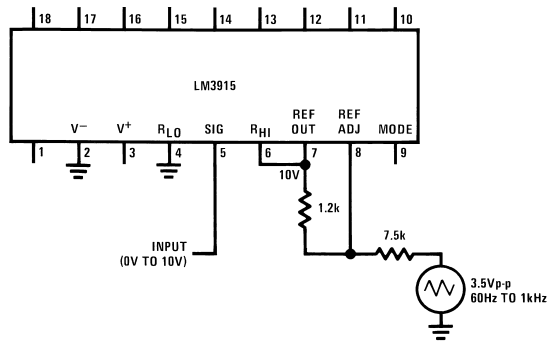

00510419

FIGURE 11. 0V to 10V Log Display with Smooth Transitions

Typical Applications (Continued)

Extended Range VU Meter

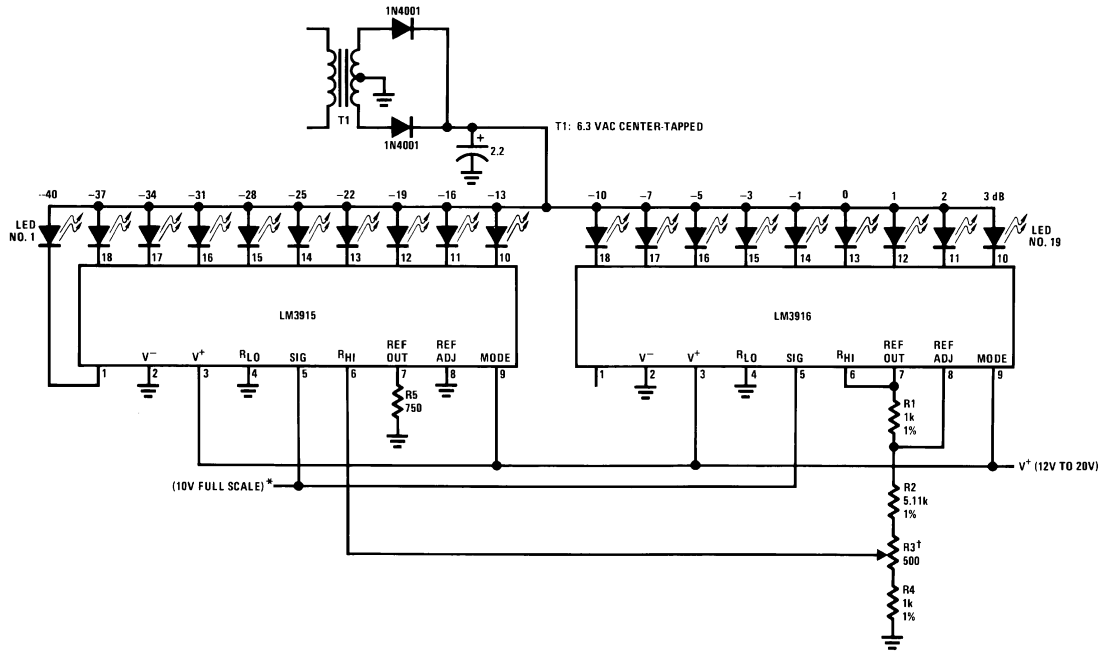

00510420

This application shows that the LED supply requires minimal filtering.

*See Application Hints for optional Peak or Average Detector.

†Adjust R3 for 3 dB difference between LED #11 and LED #12.

Vibration Meter

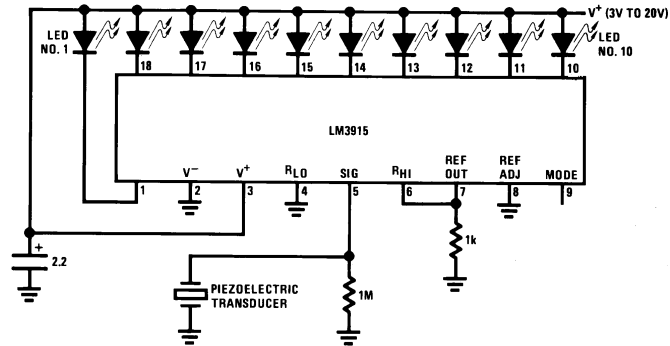

00510421

LED	Threshold
1	60 mV
2	80 mV
3	110 mV
4	160 mV
5	220 mV

LED	Threshold
6	320 mV
7	440 mV
8	630 mV
9	890 mV
10	1.25V

Typical Applications (Continued)

Indicator and Alarm, Full-Scale Changes Display from Dot to Bar

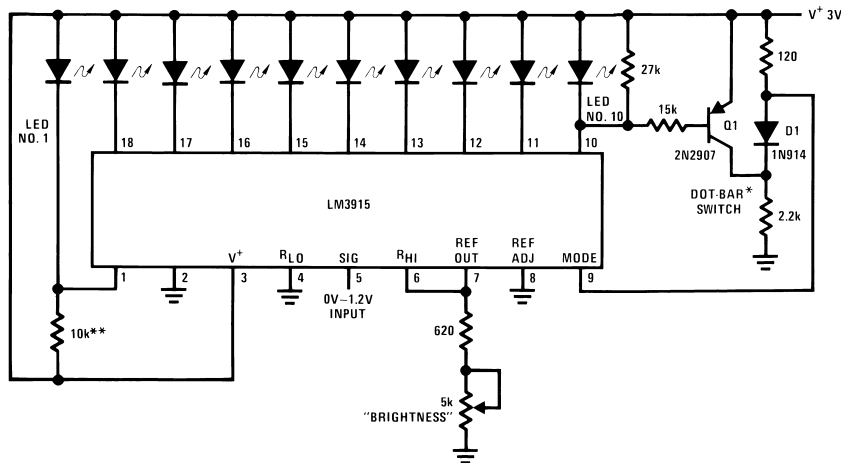

00510422

*The input to the dot bar switch may be taken from cathodes of other LEDs.

Display will change to bar as soon as the LED so selected begins to light.

**Optional. Shunts 100 μ A auxiliary sink current away from LED #1.

60 dB Dot Mode Display

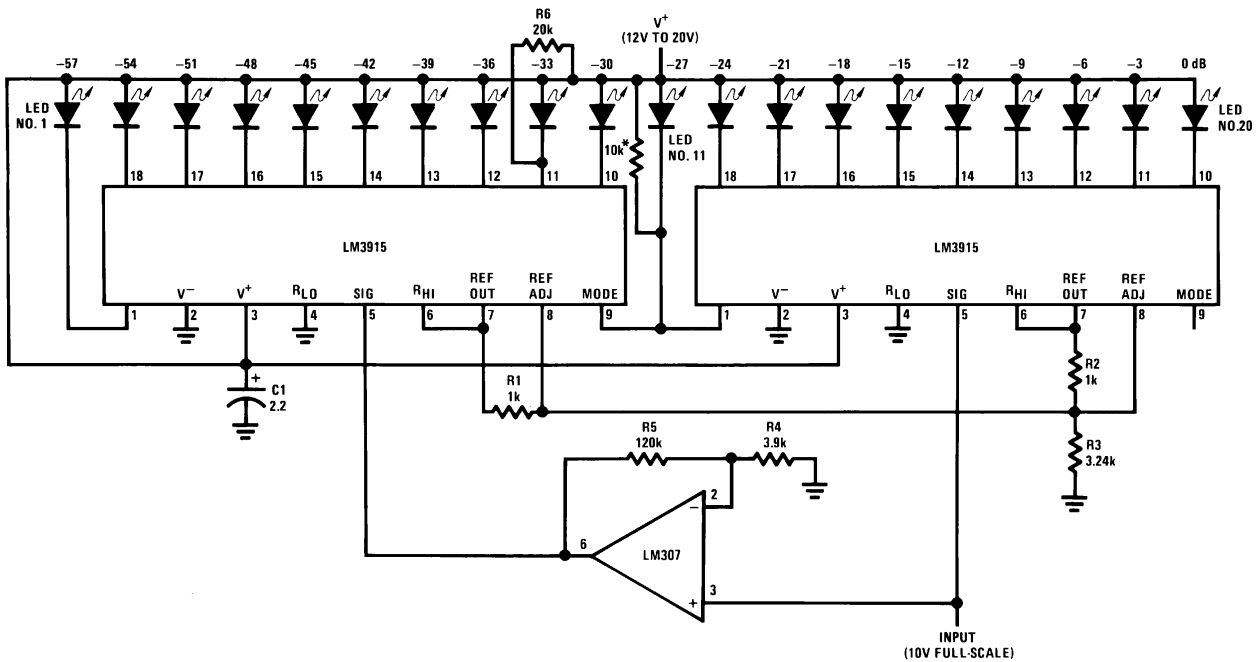

00510423

**Optional. Shunts 100 μ A auxiliary sink current away from LED #11.

Typical Applications (Continued)

Driving Vacuum Fluorescent Display

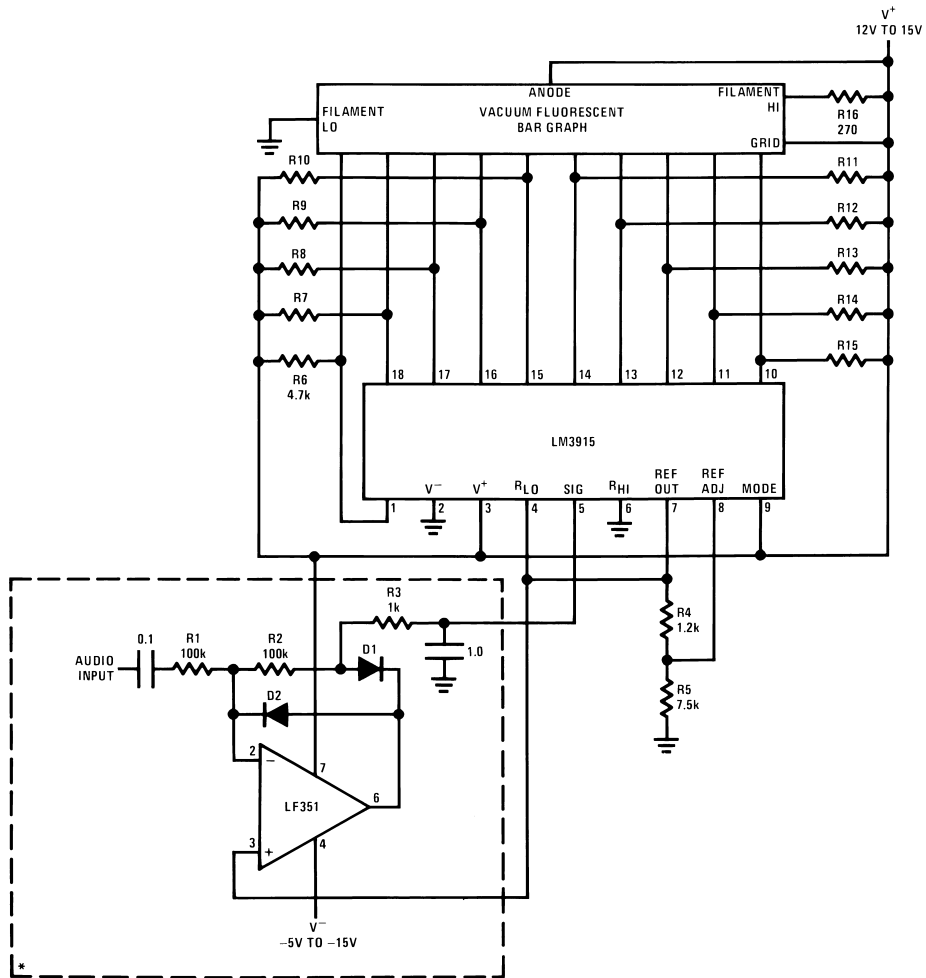

00510424

R7 thru R15: 10k ±10%
 D1, D2: 1N914 or 1N4148
 *Half-wave peak detector.
 See Application Hints.

Low Current Bar Mode Display

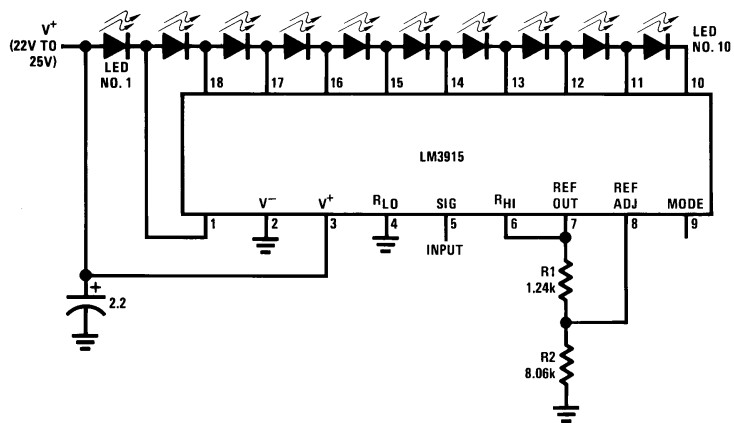

00510425

Supply current drain is only 15 mA with ten LEDs illuminated.

Typical Applications (Continued)

Driving Liquid Crystal Display

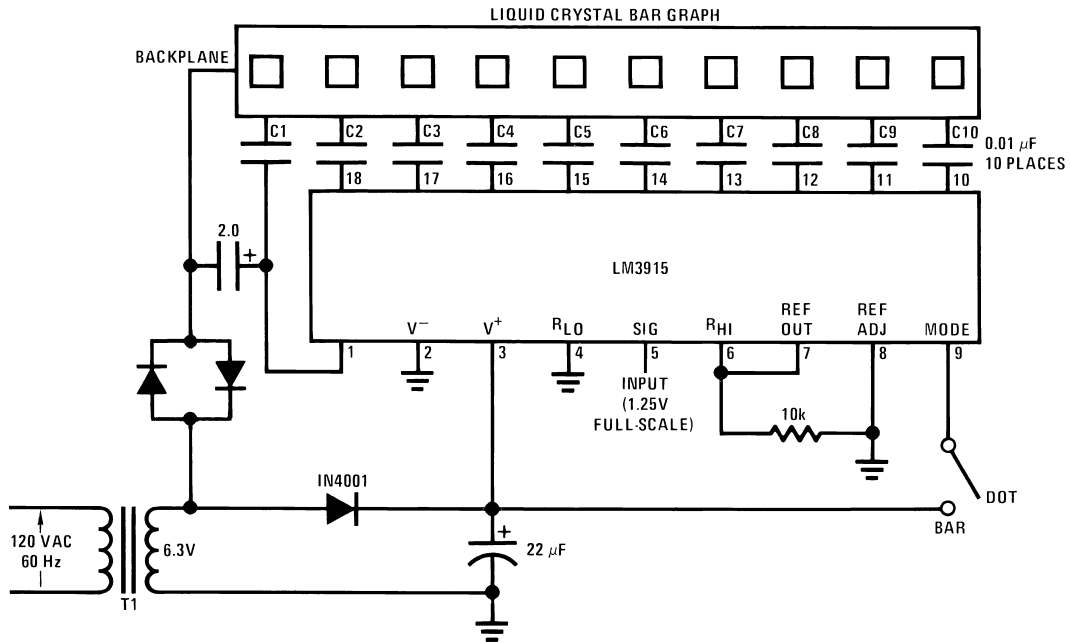

00510426

Bar Display with Alarm Flasher

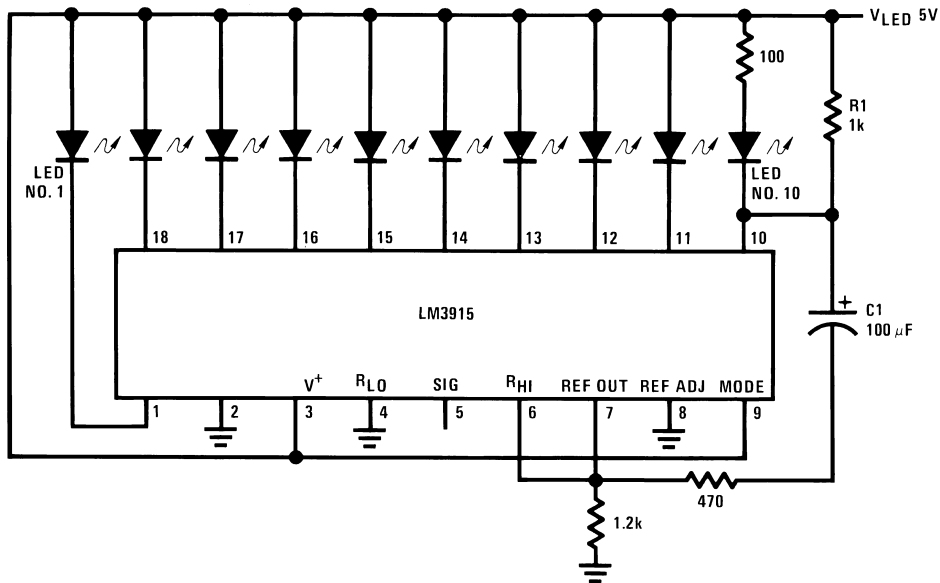

00510427

Full-scale causes the full bar display to flash. If the junction of R1 and C1 is connected to a different LED cathode, the display will flash when that LED lights, and at any higher input signal.

Typical Applications (Continued)

Precision Null Meter

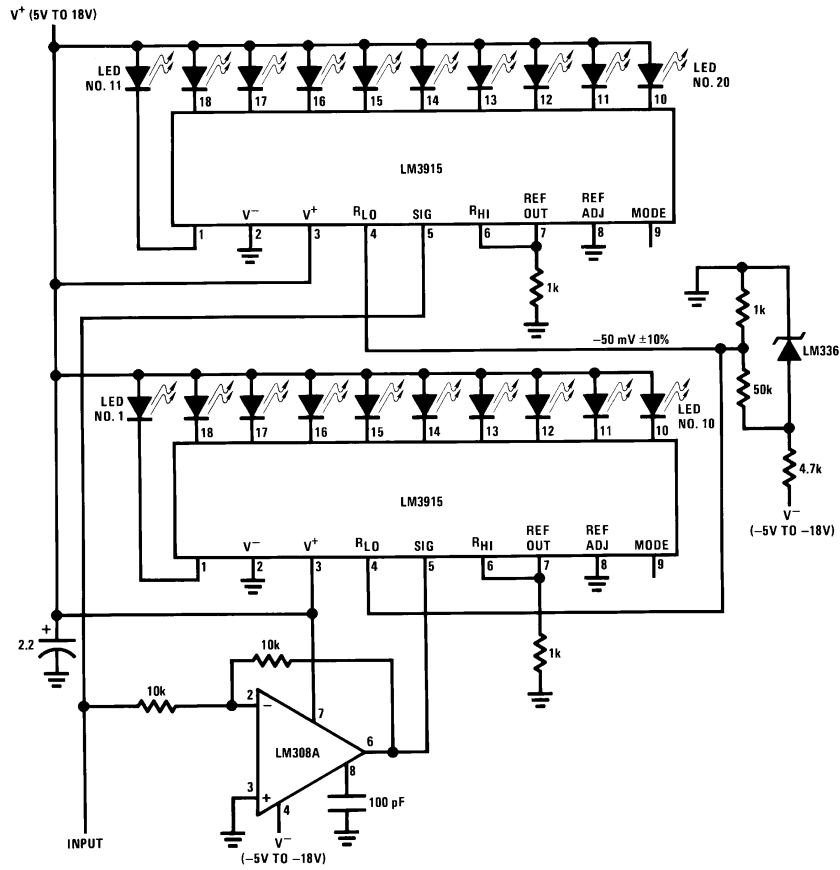

00510428

Logarithmic response allows coarse and fine adjustments without changing scale.
Resolution ranges from 10 mV at $V_{IN} = 0$ mV to 500 mV at $V_{IN} = \pm 1.25$ V.

Typical Applications (Continued)

Operating with a High Voltage Supply (Dot Mode Only)

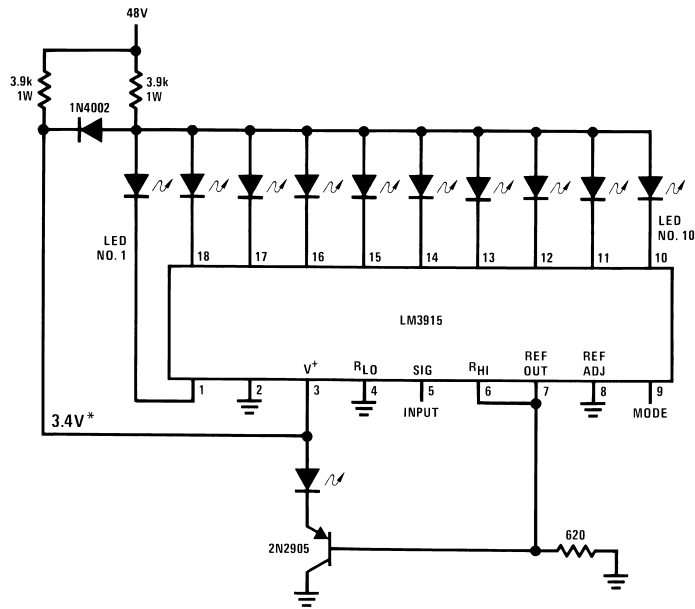

00510429

The LED currents are approximately 10 mA, and the LM3915 outputs operate in saturation for minimum dissipation.

*This point is partially regulated and decreases in voltage with temperature. Voltage requirements of the LM3915 also decrease with temperature.

Light Meter

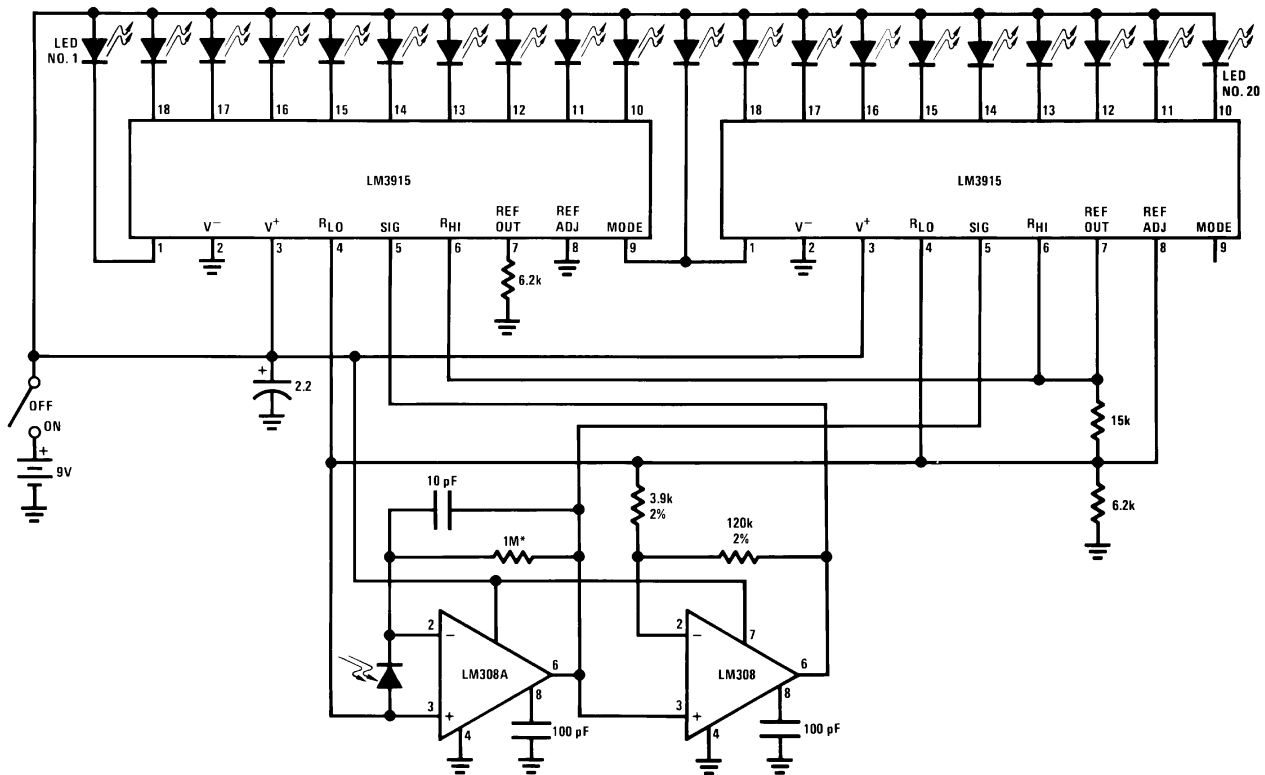

00510430

*Resistor value selects exposure
 1/2 f/stop resolution
 Ten f/stop range (1000:1)
 Typical supply current is 8 mA.

Typical Applications (Continued)

Audio Power Meter

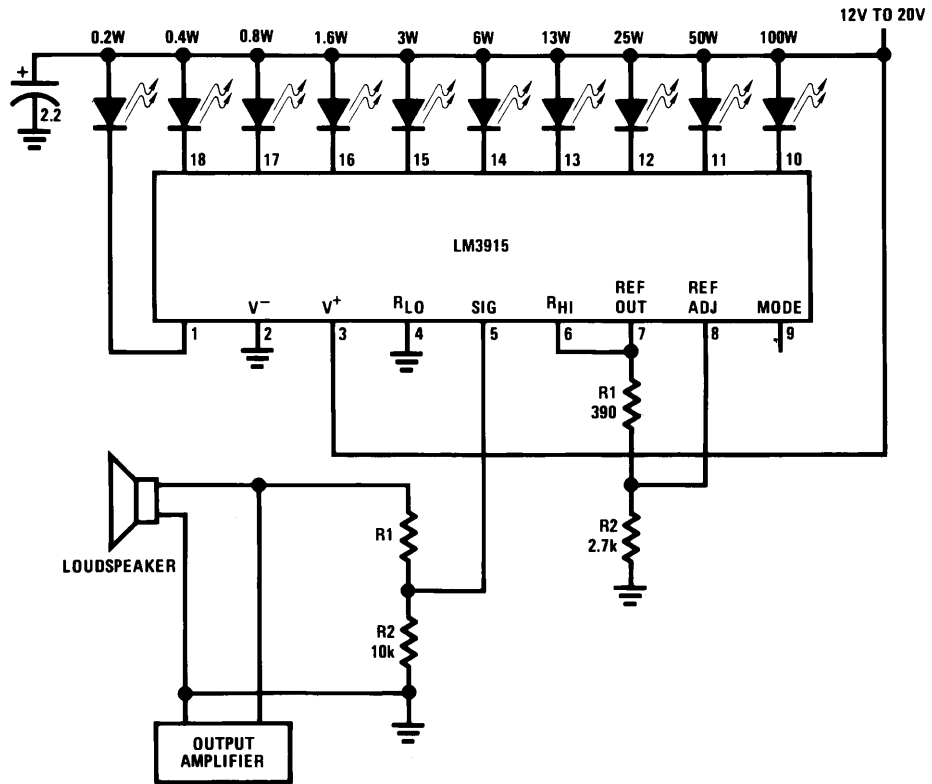

00510431

Load Impedance	R1
4Ω	10k
8Ω	18k
16Ω	30k

See Application Hints for optional Peak or Average Detector

Connection Diagram

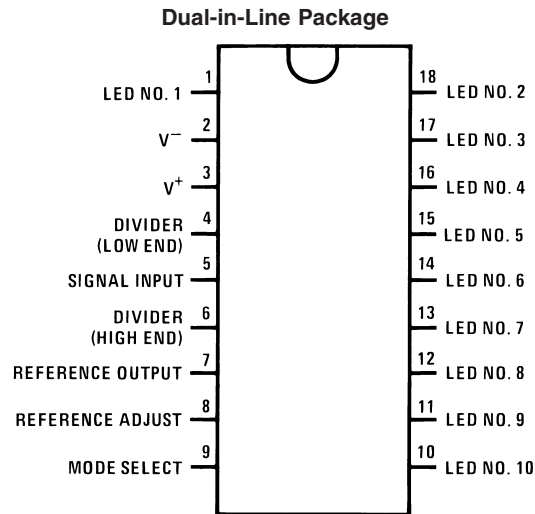

00510432

Top View

Order Number LM3915N-1
See NS Package Number NA18A
Order Number LM3915N *
See NS Package Number N18A
***Discontinued, Life Time Buy date 12/20/99**

Definition of Terms

Absolute Accuracy: The difference between the observed threshold voltage and the ideal threshold voltage for each comparator. Specified and tested with 10V across the internal voltage divider so that resistor ratio matching error predominates over comparator offset voltage.

Adjust Pin Current: Current flowing out of the reference adjust pin when the reference amplifier is in the linear region.

Comparator Gain: The ratio of the change in output current (I_{LED}) to the change in input voltage (V_{IN}) required to produce it for a comparator in the linear region.

Dropout Voltage: The voltage measured at the current source outputs required to make the output current fall by 10%.

Input Bias Current: Current flowing out of the signal input when the input buffer is in the linear region.

LED Current Regulation: The change in output current over the specified range of LED supply voltage (V_{LED}) as mea-

sured at the current source outputs. As the forward voltage of an LED does not change significantly with a small change in forward current, this is equivalent to changing the voltage at the LED anodes by the same amount.

Line Regulation: The average change in reference output voltage (V_{REF}) over the specified range of supply voltage (V^+).

Load Regulation: The change in reference output voltage over the specified range of load current ($I_{L(REF)}$).

Offset Voltage: The differential input voltage which must be applied to each comparator to bias the output in the linear region. Most significant error when the voltage across the internal voltage divider is small. Specified and tested with pin 6 voltage (V_{RHI}) equal to pin 4 voltage (V_{RLO}).

Relative Accuracy: The difference between any two adjacent threshold points. Specified and tested with 10V across the internal voltage divider so that resistor ratio matching error predominates over comparator offset voltage.

Physical Dimensions inches (millimeters) unless otherwise noted

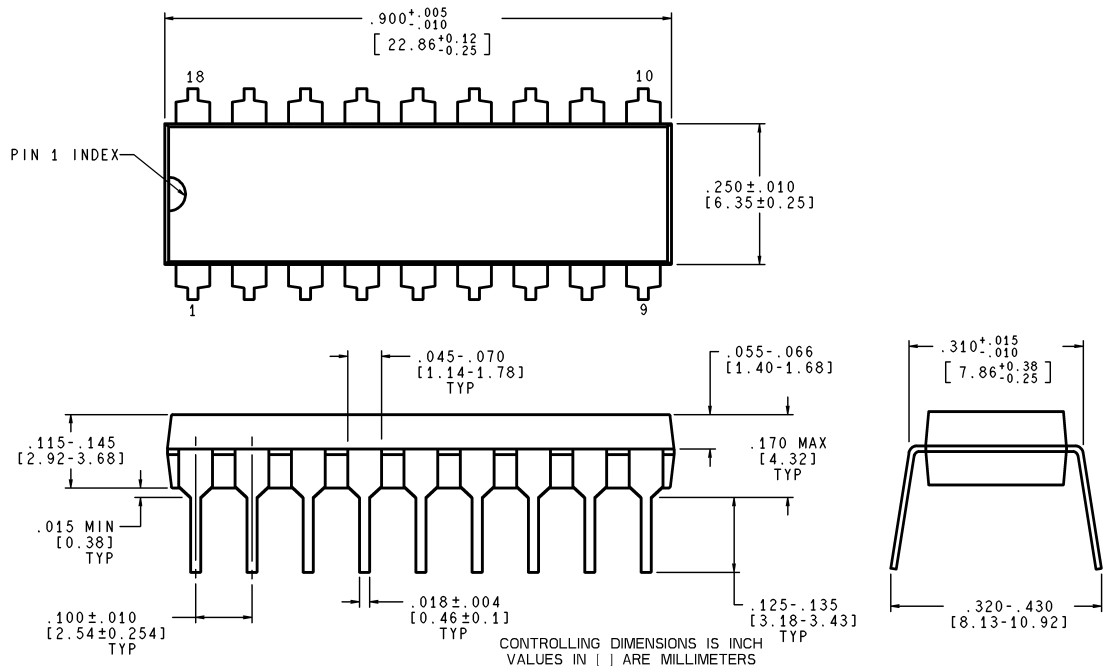

NA18A (Rev A)

Note: Unless otherwise specified.

- Standard Lead Finish:
 - 200 microinches / 5.08 micrometer minimum
 - lead/tin 37/63 or 15/85 on alloy 42 or equivalent or copper
- Reference JEDEC registration MS-001, Variation AC, dated May 1993.

Molded Dual-In-Line Package (N)
Order Number LM3915N-1
NS Package Number NA18A

Physical Dimensions inches (millimeters) unless otherwise noted (Continued)

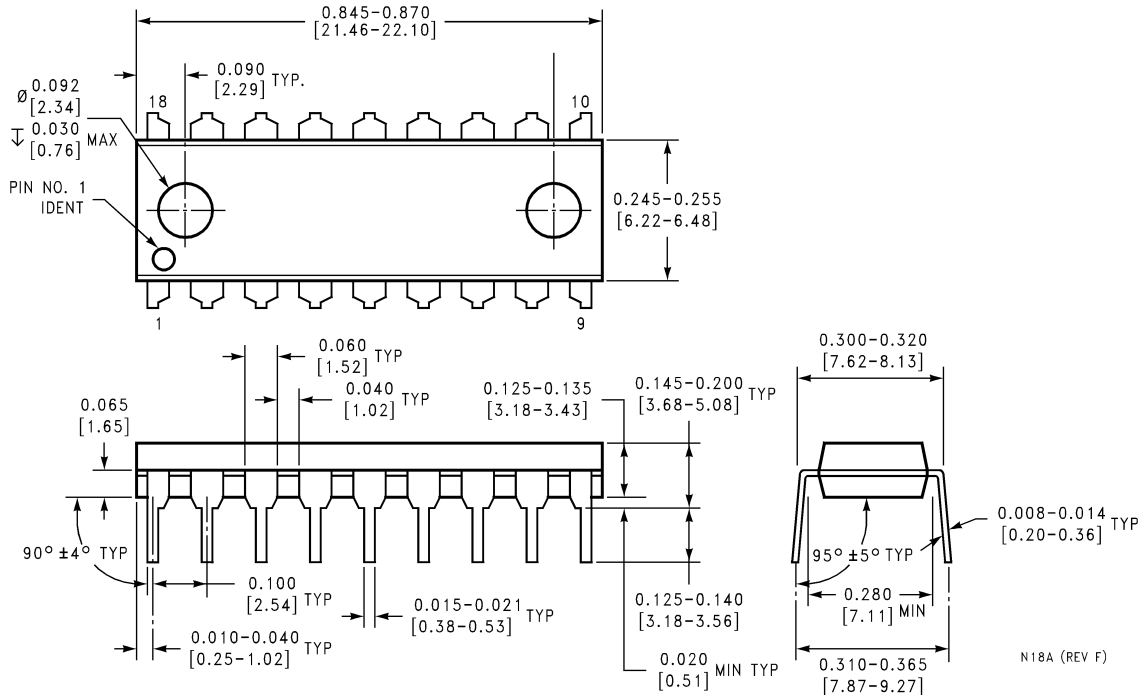

Molded Dual-In-Line Package (N)
Order Number LM3915N *
NS Package Number N18A
***Discontinued, Life Time Buy date 12/20/99**

N18A (REV F)

National does not assume any responsibility for use of any circuitry described, no circuit patent licenses are implied and National reserves the right at any time without notice to change said circuitry and specifications.

For the most current product information visit us at www.national.com.

LIFE SUPPORT POLICY

NATIONAL'S PRODUCTS ARE NOT AUTHORIZED FOR USE AS CRITICAL COMPONENTS IN LIFE SUPPORT DEVICES OR SYSTEMS WITHOUT THE EXPRESS WRITTEN APPROVAL OF THE PRESIDENT AND GENERAL COUNSEL OF NATIONAL SEMICONDUCTOR CORPORATION. As used herein:

1. Life support devices or systems are devices or systems which, (a) are intended for surgical implant into the body, or (b) support or sustain life, and whose failure to perform when properly used in accordance with instructions for use provided in the labeling, can be reasonably expected to result in a significant injury to the user.
2. A critical component is any component of a life support device or system whose failure to perform can be reasonably expected to cause the failure of the life support device or system, or to affect its safety or effectiveness.

BANNED SUBSTANCE COMPLIANCE

National Semiconductor certifies that the products and packing materials meet the provisions of the Customer Products Stewardship Specification (CSP-9-111C2) and the Banned Substances and Materials of Interest Specification (CSP-9-111S2) and contain no "Banned Substances" as defined in CSP-9-111S2.



National Semiconductor
Americas Customer Support Center
 Email: new.feedback@nsc.com
 Tel: 1-800-272-9959

National Semiconductor
Europe Customer Support Center
 Fax: +49 (0) 180-530 85 86
 Email: europa.support@nsc.com
 Deutsch Tel: +49 (0) 69 9508 6208
 English Tel: +44 (0) 870 24 0 2171
 Français Tel: +33 (0) 1 41 91 8790

National Semiconductor
Asia Pacific Customer Support Center
 Email: ap.support@nsc.com

National Semiconductor
Japan Customer Support Center
 Fax: 81-3-5639-7507
 Email: jpn.feedback@nsc.com
 Tel: 81-3-5639-7560