



HESTORE.HU

elektronikai alkatrész áruház

EN: This Datasheet is presented by the manufacturer.

Please visit our website for pricing and availability at www.hestore.hu.

74HC237

3-to-8 line decoder, demultiplexer with address latches

Rev. 03 — 12 November 2004

Product data sheet

1. General description

The 74HC237 is a high-speed Si-gate CMOS device and is pin compatible with low power Schottky TTL (LSTTL). The 74HC237 is specified in compliance with JEDEC standard no. 7A.

The 74HC237 is a 3-to-8 line decoder, demultiplexer with latches at the three address inputs (A_n). The 74HC237 essentially combines the 3-to-8 decoder function with a 3-bit storage latch. When the latch is enabled ($\overline{LE} = \text{LOW}$), the 74HC237 acts as a 3-to-8 active LOW decoder. When the latch enable (\overline{LE}) goes from LOW-to-HIGH, the last data present at the inputs before this transition, is stored in the latches. Further address changes are ignored as long as \overline{LE} remains HIGH.

The output enable input ($\overline{E1}$ and $E2$) controls the state of the outputs independent of the address inputs or latch operation. All outputs are HIGH unless $\overline{E1}$ is LOW and $E2$ is HIGH.

The 74HC237 is ideally suited for implementing non-overlapping decoders in 3-state systems and strobed (stored address) applications in bus oriented systems.

2. Features

- Combines 3-to-8 decoder with 3-bit latch
- Multiple input enable for easy expansion or independent controls
- Active HIGH mutually exclusive outputs
- Low-power dissipation
- Complies with JEDEC standard no. 7A
- ESD protection:
 - ◆ HBM EIA/JESD22-A114-B exceeds 2000 V
 - ◆ MM EIA/JESD22-A115-A exceeds 200 V.
- Multiple package options
- Specified from $-40\text{ }^{\circ}\text{C}$ to $+80\text{ }^{\circ}\text{C}$ and from $-40\text{ }^{\circ}\text{C}$ to $+125\text{ }^{\circ}\text{C}$.

PHILIPS

3. Quick reference data

Table 1: Quick reference data

$GND = 0\text{ V}$; $T_{amb} = 25\text{ °C}$; $t_r = t_f = 6\text{ ns}$.

Symbol	Parameter	Conditions	Min	Typ	Max	Unit
t_{PHL} , t_{PLH}	propagation delay	$C_L = 15\text{ pF}$; $V_{CC} = 5\text{ V}$				
	An to Yn		-	16	-	ns
	\overline{LE} to Yn		-	19	-	ns
	$\overline{E1}$ to Yn		-	14	-	ns
	E2 to Yn		-	14	-	ns
C_i	input capacitance		-	3.5	-	pF
C_{PD}	power dissipation capacitance	$V_I = GND$ to V_{CC}	[1]	-	60	-

[1] C_{PD} is used to determine the dynamic power dissipation (P_D in μW).

$P_D = C_{PD} \times V_{CC}^2 \times f_i \times N + \sum(C_L \times V_{CC}^2 \times f_o)$ where:

f_i = input frequency in MHz;

f_o = output frequency in MHz;

C_L = output load capacitance in pF;

V_{CC} = supply voltage in V;

N = number of inputs switching;

$\sum(C_L \times V_{CC}^2 \times f_o)$ = sum of outputs.

4. Ordering information

Table 2: Ordering information

Type number	Package			
	Temperature range	Name	Description	Version
74HC237N	-40 °C to +125 °C	DIP16	plastic dual in-line package; 16 leads (300 mil)	SOT38-4
74HC237D	-40 °C to +125 °C	SO16	plastic small outline package; 16 leads; body width 3.9 mm	SOT109-1
74HC237DB	-40 °C to +125 °C	SSOP16	plastic shrink small outline package; 16 leads; body width 5.3 mm	SOT338-1

5. Functional diagram

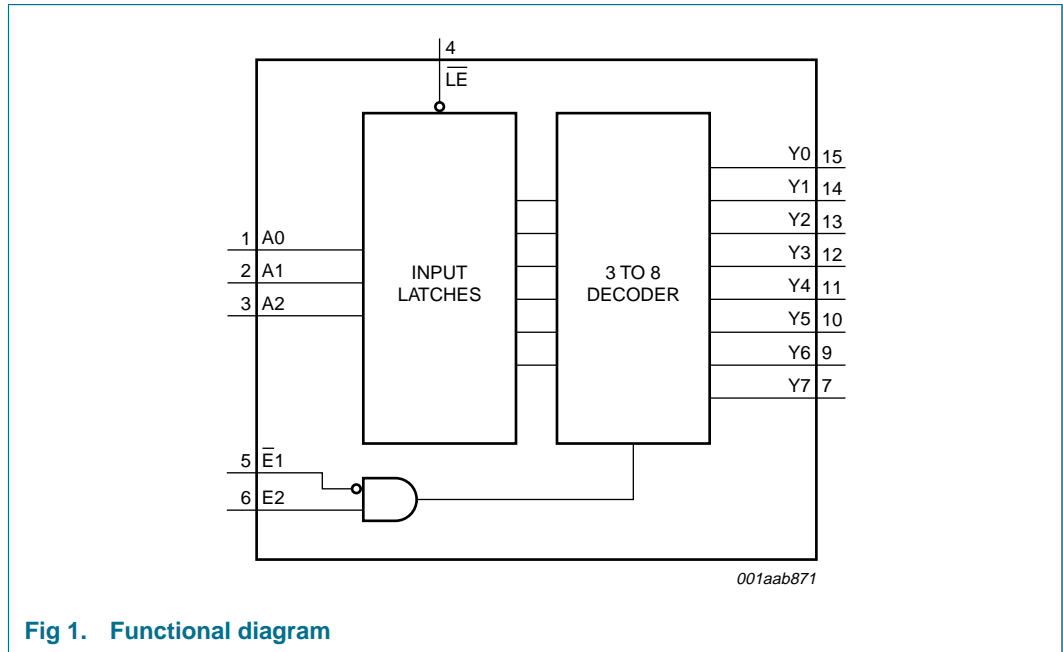

Fig 1. Functional diagram

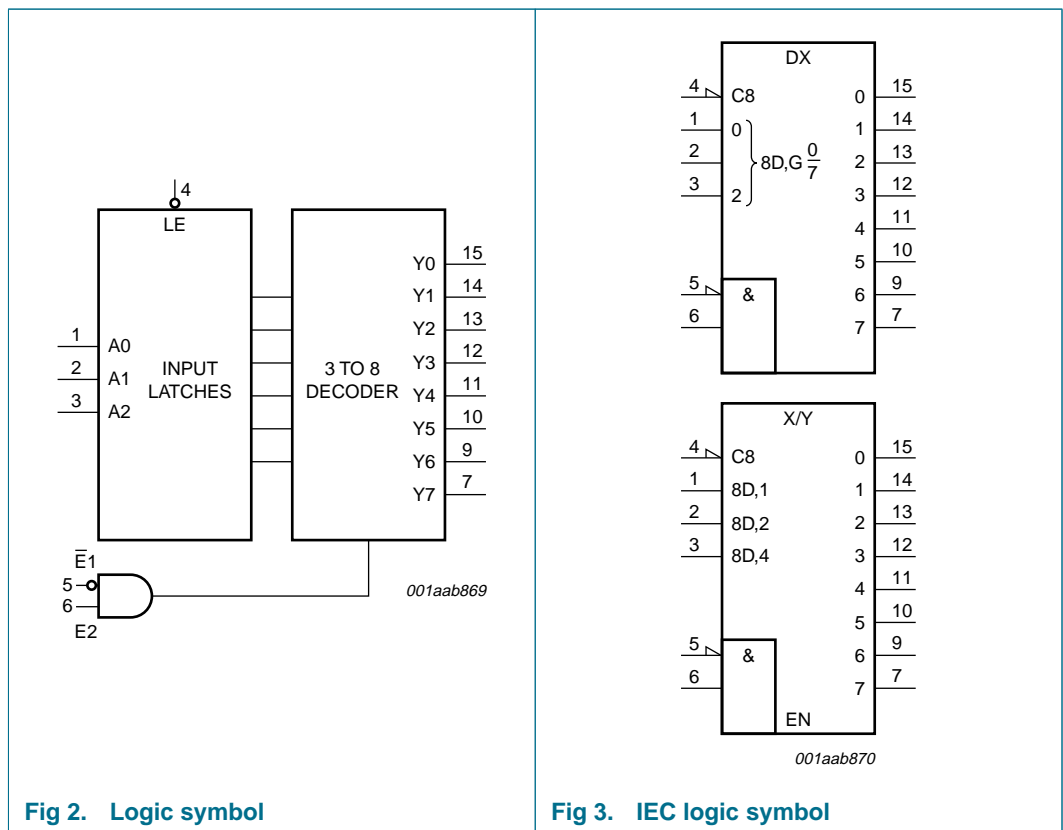
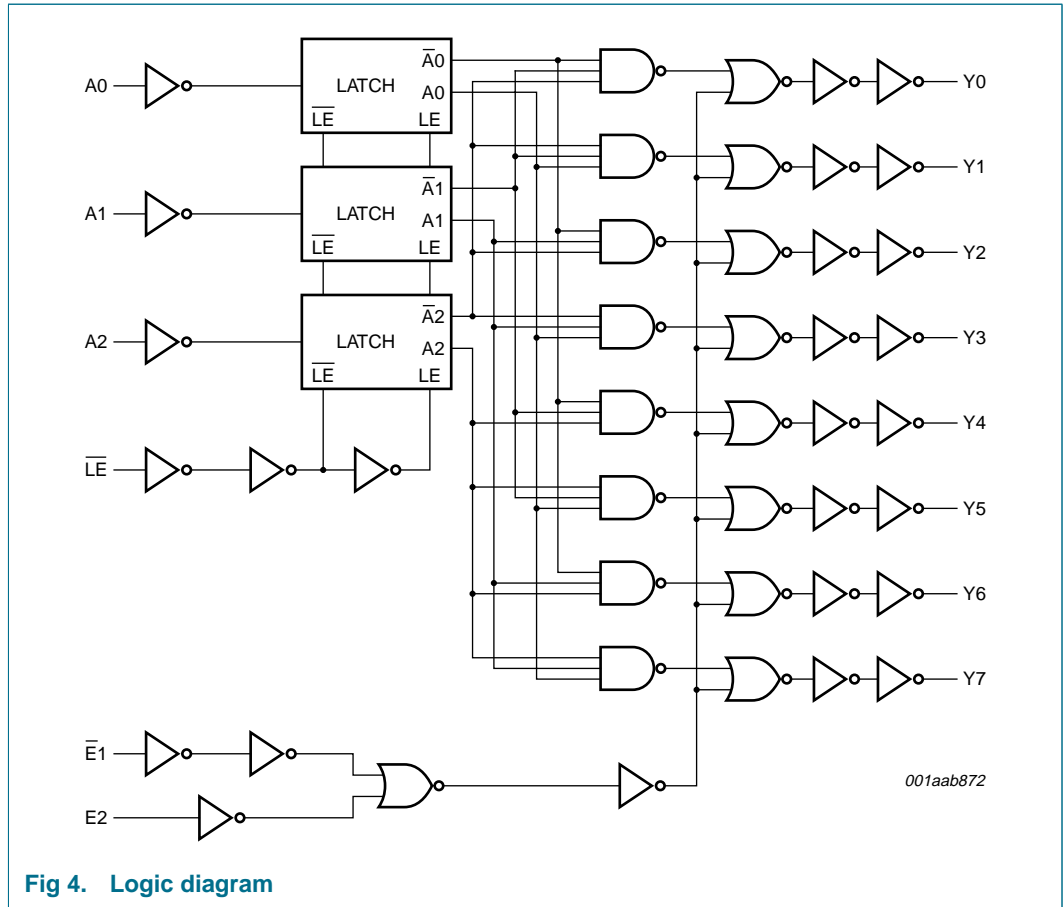

Fig 2. Logic symbol

Fig 3. IEC logic symbol



6. Pinning information

6.1 Pinning

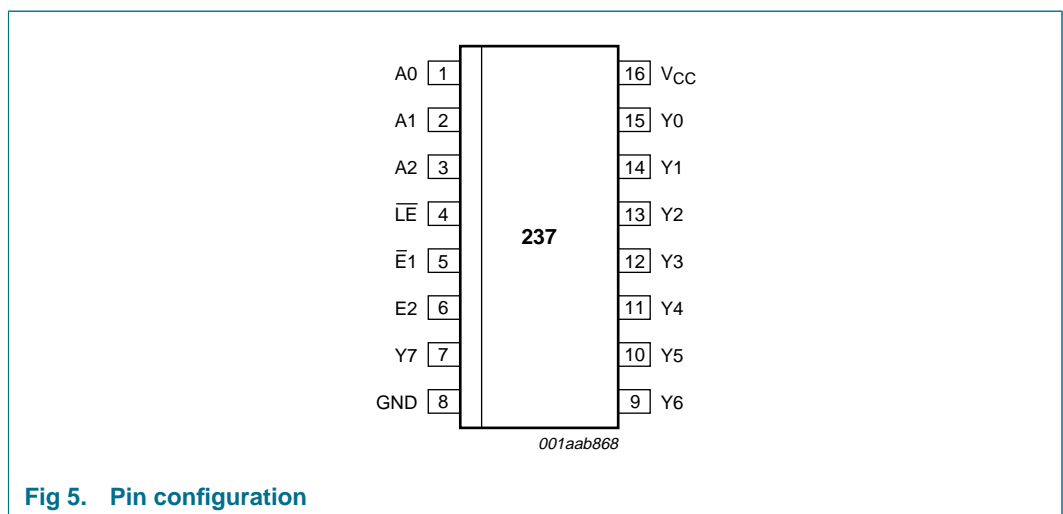

6.2 Pin description

Table 3: Pin description

Symbol	Pin	Description
A0	1	data input 0
A1	2	data input 1
A2	3	data input 2
$\overline{\text{LE}}$	4	latch enable input (active LOW)
$\overline{\text{E1}}$	5	data enable input 1 (active LOW)
E2	6	data enable input 2 (active HIGH)
Y7	7	multiplexer output 7
GND	8	ground (0 V)
Y6	9	multiplexer output 6
Y5	10	multiplexer output 5
Y4	11	multiplexer output 4
Y3	12	multiplexer output 3
Y2	13	multiplexer output 2
Y1	14	multiplexer output 1
Y0	15	multiplexer output 0
V _{CC}	16	positive supply voltage

7. Functional description

7.1 Function table

Table 4: Function table

Enable			Input			Output							
$\overline{\text{LE}}$	$\overline{\text{E1}}$	E2	A0	A1	A2	Y0	Y1	Y2	Y3	Y4	Y5	Y6	Y7
H	L	H	X	X	X	stable							
X	H	X	X	X	X	L	L	L	L	L	L	L	L
X	X	L	X	X	X	L	L	L	L	L	L	L	L
L	L	H	L	L	L	H	L	L	L	L	L	L	L
			H	L	L	L	H	L	L	L	L	L	L
			L	H	L	L	L	H	L	L	L	L	L
			H	H	L	L	L	L	H	L	L	L	L
			L	L	H	L	L	L	L	H	L	L	L
			H	L	H	L	L	L	L	L	H	L	L
			L	H	H	L	L	L	L	L	L	H	L
			H	H	H	L	L	L	L	L	L	L	L

[1] H = HIGH voltage level;
L = LOW voltage level;
X = don't care.

8. Limiting values

Table 5: Limiting values

In accordance with the Absolute Maximum Rating System (IEC 60134). Voltages are referenced to GND (ground = 0 V).

Symbol	Parameter	Conditions	Min	Max	Unit
V_{CC}	supply voltage		-0.5	+7	V
I_{IK}	input diode current	$V_I < -0.5\text{ V}$ or $V_I > V_{CC} + 0.5\text{ V}$	-	± 20	mA
I_{OK}	output diode current	$V_O < -0.5\text{ V}$ or $V_O > V_{CC} + 0.5\text{ V}$	-	± 20	mA
I_O	output source or sink current	$V_O = -0.5\text{ V}$ to $V_{CC} + 0.5\text{ V}$	-	± 25	mA
I_{CC}, I_{GND}	V_{CC} or GND current		-	± 50	mA
T_{stg}	storage temperature		-65	+150	°C
P_{tot}	power dissipation				
	DIP16 package		[1] -	750	mW
	SO16 and SSOP16 packages		[2] -	500	mW

[1] Above 70 °C: P_{tot} derates linearly with 12 mW/K.

[2] Above 70 °C: P_{tot} derates linearly with 8 mW/K.

9. Recommended operating conditions

Table 6: Recommended operating conditions

Symbol	Parameter	Conditions	Min	Typ	Max	Unit
V_{CC}	supply voltage		2.0	5.0	6.0	V
V_I	input voltage		0	-	V_{CC}	V
V_O	output voltage		0	-	V_{CC}	V
t_r, t_f	input rise and fall times	$V_{CC} = 2.0\text{ V}$	-	-	1000	ns
		$V_{CC} = 4.5\text{ V}$	-	6.0	500	ns
		$V_{CC} = 6.0\text{ V}$	-	-	400	ns
T_{amb}	ambient temperature		-40	-	+125	°C

10. Static characteristics

Table 7: Static characteristics

At recommended operating conditions; voltages are referenced to GND (ground = 0 V).

Symbol	Parameter	Conditions	Min	Typ	Max	Unit
T_{amb} = 25 °C						
V _{IH}	HIGH-level input voltage	V _{CC} = 2.0 V	1.5	1.2	-	V
		V _{CC} = 4.5 V	3.15	2.4	-	V
		V _{CC} = 6.0 V	4.2	3.2	-	V
V _{IL}	LOW-level input voltage	V _{CC} = 2.0 V	-	0.8	0.5	V
		V _{CC} = 4.5 V	-	2.1	1.35	V
		V _{CC} = 6.0 V	-	2.8	1.8	V
V _{OH}	HIGH-level output voltage	V _I = V _{IH} or V _{IL}				
		I _O = -20 μA; V _{CC} = 2.0 V	1.9	2.0	-	V
		I _O = -20 μA; V _{CC} = 4.5 V	4.4	4.5	-	V
		I _O = -20 μA; V _{CC} = 6.0 V	5.9	6.0	-	V
		I _O = -4 mA; V _{CC} = 4.5 V	3.98	4.32	-	V
V _{OL}	LOW-level output voltage	V _I = V _{IH} or V _{IL}				
		I _O = 20 μA; V _{CC} = 2.0 V	-	0	0.1	V
		I _O = 20 μA; V _{CC} = 4.5 V	-	0	0.1	V
		I _O = 20 μA; V _{CC} = 6.0 V	-	0	0.1	V
		I _O = 4 mA; V _{CC} = 4.5 V	-	0.15	0.26	V
I _{LI}	input leakage current	V _I = V _{CC} or GND; V _{CC} = 6.0 V	-	-	±0.1	μA
		V _{CC} = 6.0 V	-	-	8.0	μA
I _{CC}	quiescent supply current	V _I = V _{CC} or GND; I _O = 0 A; V _{CC} = 6.0 V	-	-	8.0	μA
C _I	input capacitance		-	3.5	-	pF
T_{amb} = -40 °C to +85 °C						
V _{IH}	HIGH-level input voltage	V _{CC} = 2.0 V	1.5	-	-	V
		V _{CC} = 4.5 V	3.15	-	-	V
		V _{CC} = 6.0 V	4.2	-	-	V
V _{IL}	LOW-level input voltage	V _{CC} = 2.0 V	-	-	0.5	V
		V _{CC} = 4.5 V	-	-	1.35	V
		V _{CC} = 6.0 V	-	-	1.8	V
V _{OH}	HIGH-level output voltage	V _I = V _{IH} or V _{IL}				
		I _O = -20 μA; V _{CC} = 2.0 V	1.9	-	-	V
		I _O = -20 μA; V _{CC} = 4.5 V	4.4	-	-	V
		I _O = -20 μA; V _{CC} = 6.0 V	5.9	-	-	V
		I _O = -4 mA; V _{CC} = 4.5 V	3.84	-	-	V
I _O = -5.2 mA; V _{CC} = 6.0 V		5.34	-	-	V	

Table 7: Static characteristics ...continued

At recommended operating conditions; voltages are referenced to GND (ground = 0 V).

Symbol	Parameter	Conditions	Min	Typ	Max	Unit
V _{OL}	LOW-level output voltage	V _I = V _{IH} or V _{IL}				
		I _O = 20 μA; V _{CC} = 2.0 V	-	-	0.1	V
		I _O = 20 μA; V _{CC} = 4.5 V	-	-	0.1	V
		I _O = 20 μA; V _{CC} = 6.0 V	-	-	0.1	V
		I _O = 4 mA; V _{CC} = 4.5 V	-	-	0.33	V
		I _O = 5.2 mA; V _{CC} = 6.0 V	-	-	0.33	V
I _{LI}	input leakage current	V _I = V _{CC} or GND; V _{CC} = 6.0 V	-	-	±1.0	μA
I _{CC}	quiescent supply current	V _I = V _{CC} or GND; I _O = 0 A; V _{CC} = 6.0 V	-	-	80	μA
T_{amb} = -40 °C to +125 °C						
V _{IH}	HIGH-level input voltage	V _{CC} = 2.0 V	1.5	-	-	V
		V _{CC} = 4.5 V	3.15	-	-	V
		V _{CC} = 6.0 V	4.2	-	-	V
V _{IL}	LOW-level input voltage	V _{CC} = 2.0 V	-	-	0.5	V
		V _{CC} = 4.5 V	-	-	1.35	V
		V _{CC} = 6.0 V	-	-	1.8	V
V _{OH}	HIGH-level output voltage	V _I = V _{IH} or V _{IL}				
		I _O = -20 μA; V _{CC} = 2.0 V	1.9	-	-	V
		I _O = -20 μA; V _{CC} = 4.5 V	4.4	-	-	V
		I _O = -20 μA; V _{CC} = 6.0 V	5.9	-	-	V
		I _O = -4 mA; V _{CC} = 4.5 V	3.7	-	-	V
		I _O = -5.2 mA; V _{CC} = 6.0 V	5.2	-	-	V
V _{OL}	LOW-level output voltage	V _I = V _{IH} or V _{IL}				
		I _O = 20 μA; V _{CC} = 2.0 V	-	-	0.1	V
		I _O = 20 μA; V _{CC} = 4.5 V	-	-	0.1	V
		I _O = 20 μA; V _{CC} = 6.0 V	-	-	0.1	V
		I _O = 4 mA; V _{CC} = 4.5 V	-	-	0.4	V
		I _O = 5.2 mA; V _{CC} = 6.0 V	-	-	0.4	V
I _{LI}	input leakage current	V _I = V _{CC} or GND; V _{CC} = 6.0 V	-	-	±1.0	μA
I _{CC}	quiescent supply current	V _I = V _{CC} or GND; I _O = 0 A; V _{CC} = 6.0 V	-	-	160	μA

11. Dynamic characteristics

Table 8: Dynamic characteristics

$GND = 0\text{ V}$; $t_r = t_f = 6\text{ ns}$; $C_L = 50\text{ pF}$; see [Figure 9](#).

Symbol	Parameter	Conditions	Min	Typ	Max	Unit	
$T_{\text{amb}} = 25\text{ °C}$							
t_{PHL} , t_{PLH}	propagation delay A_n to Y_n	see Figure 6					
		$V_{\text{CC}} = 2.0\text{ V}$	-	52	160	ns	
		$V_{\text{CC}} = 4.5\text{ V}$	-	19	32	ns	
		$V_{\text{CC}} = 6.0\text{ V}$	-	15	27	ns	
		$V_{\text{CC}} = 5.0\text{ V}$; $C_L = 15\text{ pF}$	-	16	-	ns	
	propagation delay \overline{LE} to Y_n	see Figure 6					
		$V_{\text{CC}} = 2.0\text{ V}$	-	61	190	ns	
		$V_{\text{CC}} = 4.5\text{ V}$	-	22	38	ns	
		$V_{\text{CC}} = 6.0\text{ V}$	-	18	32	ns	
		$V_{\text{CC}} = 5.0\text{ V}$; $C_L = 15\text{ pF}$	-	19	-	ns	
	propagation delay $\overline{E1}$ to Y_n	see Figure 7					
		$V_{\text{CC}} = 2.0\text{ V}$	-	47	145	ns	
		$V_{\text{CC}} = 4.5\text{ V}$	-	17	29	ns	
		$V_{\text{CC}} = 6.0\text{ V}$	-	14	25	ns	
		$V_{\text{CC}} = 5.0\text{ V}$; $C_L = 15\text{ pF}$	-	14	-	ns	
	propagation delay $E2$ to Y_n	see Figure 6					
$V_{\text{CC}} = 2.0\text{ V}$		-	47	145	ns		
$V_{\text{CC}} = 4.5\text{ V}$		-	17	29	ns		
$V_{\text{CC}} = 6.0\text{ V}$		-	14	25	ns		
	$V_{\text{CC}} = 5.0\text{ V}$; $C_L = 15\text{ pF}$	-	14	-	ns		
t_{THL} , t_{TLH}	output transition time	see Figure 7					
		$V_{\text{CC}} = 2.0\text{ V}$	-	19	75	ns	
		$V_{\text{CC}} = 4.5\text{ V}$	-	7	15	ns	
		$V_{\text{CC}} = 6.0\text{ V}$	-	6	13	ns	
t_w	\overline{LE} pulse width HIGH	see Figure 8					
		$V_{\text{CC}} = 2.0\text{ V}$	50	11	-	ns	
		$V_{\text{CC}} = 4.5\text{ V}$	10	4	-	ns	
		$V_{\text{CC}} = 6.0\text{ V}$	9	3	-	ns	
t_{su}	set-up time A_n to \overline{LE}	see Figure 8					
		$V_{\text{CC}} = 2.0\text{ V}$	50	6	-	ns	
		$V_{\text{CC}} = 4.5\text{ V}$	10	2	-	ns	
		$V_{\text{CC}} = 6.0\text{ V}$	9	2	-	ns	
t_h	hold time A_n to \overline{LE}	see Figure 8					
		$V_{\text{CC}} = 2.0\text{ V}$	30	3	-	ns	
		$V_{\text{CC}} = 4.5\text{ V}$	6	1	-	ns	
		$V_{\text{CC}} = 6.0\text{ V}$	5	1	-	ns	
C_{PD}	power dissipation capacitance	$V_I = GND$ to V_{CC}	[1] -	60	-	pF	

Table 8: Dynamic characteristics ...continued
 $GND = 0\text{ V}$; $t_r = t_f = 6\text{ ns}$; $C_L = 50\text{ pF}$; see [Figure 9](#).

Symbol	Parameter	Conditions	Min	Typ	Max	Unit		
$T_{\text{amb}} = -40\text{ °C to }+85\text{ °C}$								
$t_{\text{PHL}}, t_{\text{PLH}}$	propagation delay A_n to Y_n	see Figure 6						
		$V_{\text{CC}} = 2.0\text{ V}$	-	-	200	ns		
		$V_{\text{CC}} = 4.5\text{ V}$	-	-	40	ns		
			$V_{\text{CC}} = 6.0\text{ V}$	-	-	34	ns	
	propagation delay \overline{LE} to Y_n	see Figure 6						
		$V_{\text{CC}} = 2.0\text{ V}$	-	-	240	ns		
		$V_{\text{CC}} = 4.5\text{ V}$	-	-	48	ns		
		$V_{\text{CC}} = 6.0\text{ V}$	-	-	41	ns		
		propagation delay $\overline{E1}$ to Y_n	see Figure 7					
			$V_{\text{CC}} = 2.0\text{ V}$	-	-	180	ns	
	$V_{\text{CC}} = 4.5\text{ V}$		-	-	36	ns		
			$V_{\text{CC}} = 6.0\text{ V}$	-	-	31	ns	
propagation delay $E2$ to Y_n	see Figure 6							
	$V_{\text{CC}} = 2.0\text{ V}$	-	-	180	ns			
	$V_{\text{CC}} = 4.5\text{ V}$	-	-	36	ns			
	$V_{\text{CC}} = 6.0\text{ V}$	-	-	31	ns			
	$t_{\text{THL}}, t_{\text{TLH}}$	output transition time	see Figure 7					
			$V_{\text{CC}} = 2.0\text{ V}$	-	-	95	ns	
$V_{\text{CC}} = 4.5\text{ V}$			-	-	19	ns		
$V_{\text{CC}} = 6.0\text{ V}$			-	-	16	ns		
t_w	\overline{LE} pulse width HIGH	see Figure 8						
		$V_{\text{CC}} = 2.0\text{ V}$	65	-	-	ns		
		$V_{\text{CC}} = 4.5\text{ V}$	13	-	-	ns		
		$V_{\text{CC}} = 6.0\text{ V}$	11	-	-	ns		
t_{su}	set-up time A_n to \overline{LE}	see Figure 8						
		$V_{\text{CC}} = 2.0\text{ V}$	65	-	-	ns		
		$V_{\text{CC}} = 4.5\text{ V}$	13	-	-	ns		
		$V_{\text{CC}} = 6.0\text{ V}$	11	-	-	ns		
t_h	hold time A_n to \overline{LE}	see Figure 8						
		$V_{\text{CC}} = 2.0\text{ V}$	40	-	-	ns		
		$V_{\text{CC}} = 4.5\text{ V}$	8	-	-	ns		
		$V_{\text{CC}} = 6.0\text{ V}$	7	-	-	ns		

Table 8: Dynamic characteristics ...continued
 $GND = 0\text{ V}$; $t_r = t_f = 6\text{ ns}$; $C_L = 50\text{ pF}$; see [Figure 9](#).

Symbol	Parameter	Conditions	Min	Typ	Max	Unit		
$T_{\text{amb}} = -40\text{ °C to }+125\text{ °C}$								
$t_{\text{PHL}}, t_{\text{PLH}}$	propagation delay A_n to Y_n	see Figure 6						
		$V_{\text{CC}} = 2.0\text{ V}$	-	-	240	ns		
		$V_{\text{CC}} = 4.5\text{ V}$	-	-	48	ns		
			$V_{\text{CC}} = 6.0\text{ V}$	-	-	41	ns	
	propagation delay \overline{LE} to Y_n	see Figure 6						
		$V_{\text{CC}} = 2.0\text{ V}$	-	-	285	ns		
		$V_{\text{CC}} = 4.5\text{ V}$	-	-	57	ns		
		$V_{\text{CC}} = 6.0\text{ V}$	-	-	48	ns		
		propagation delay $\overline{E1}$ to Y_n	see Figure 7					
			$V_{\text{CC}} = 2.0\text{ V}$	-	-	220	ns	
	$V_{\text{CC}} = 4.5\text{ V}$		-	-	44	ns		
			$V_{\text{CC}} = 6.0\text{ V}$	-	-	38	ns	
propagation delay $E2$ to Y_n	see Figure 6							
	$V_{\text{CC}} = 2.0\text{ V}$	-	-	220	ns			
	$V_{\text{CC}} = 4.5\text{ V}$	-	-	44	ns			
	$V_{\text{CC}} = 6.0\text{ V}$	-	-	38	ns			
	$t_{\text{THL}}, t_{\text{TLH}}$	output transition time	see Figure 7					
			$V_{\text{CC}} = 2.0\text{ V}$	-	-	110	ns	
$V_{\text{CC}} = 4.5\text{ V}$			-	-	22	ns		
$V_{\text{CC}} = 6.0\text{ V}$			-	-	19	ns		
t_w	\overline{LE} pulse width HIGH	see Figure 8						
		$V_{\text{CC}} = 2.0\text{ V}$	75	-	-	ns		
		$V_{\text{CC}} = 4.5\text{ V}$	15	-	-	ns		
		$V_{\text{CC}} = 6.0\text{ V}$	13	-	-	ns		
t_{su}	set-up time A_n to \overline{LE}	see Figure 8						
		$V_{\text{CC}} = 2.0\text{ V}$	75	-	-	ns		
		$V_{\text{CC}} = 4.5\text{ V}$	15	-	-	ns		
		$V_{\text{CC}} = 6.0\text{ V}$	13	-	-	ns		
t_h	hold time A_n to \overline{LE}	see Figure 8						
		$V_{\text{CC}} = 2.0\text{ V}$	45	-	-	ns		
		$V_{\text{CC}} = 4.5\text{ V}$	9	-	-	ns		
		$V_{\text{CC}} = 6.0\text{ V}$	8	-	-	ns		

[1] C_{PD} is used to determine the dynamic power dissipation (P_D in μW).

$P_D = C_{\text{PD}} \times V_{\text{CC}}^2 \times f_i \times N + \sum(C_L \times V_{\text{CC}}^2 \times f_o)$ where:

f_i = input frequency in MHz;

f_o = output frequency in MHz;

C_L = output load capacitance in pF;

V_{CC} = supply voltage in V;

N = number of inputs switching;

$\sum(C_L \times V_{\text{CC}}^2 \times f_o)$ = sum of outputs.

12. Waveforms

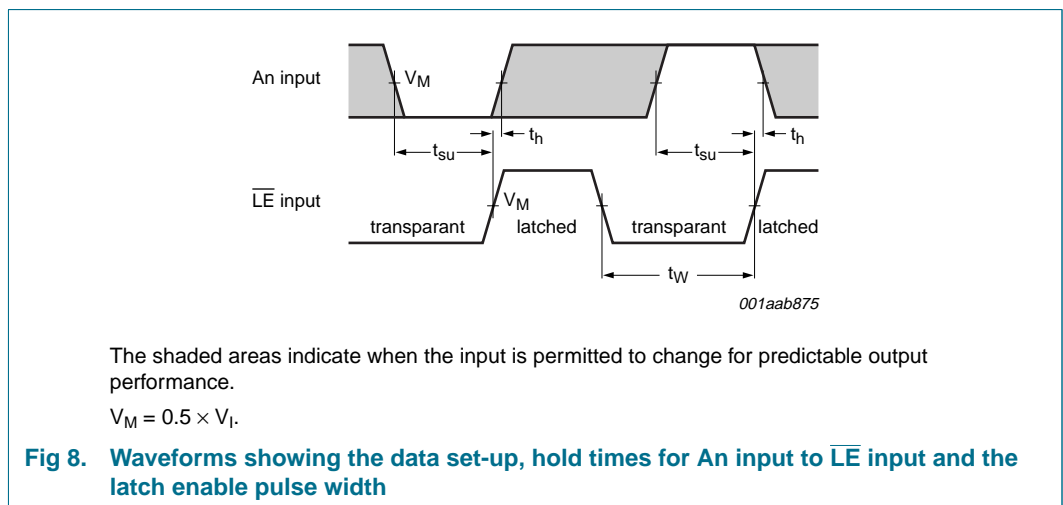
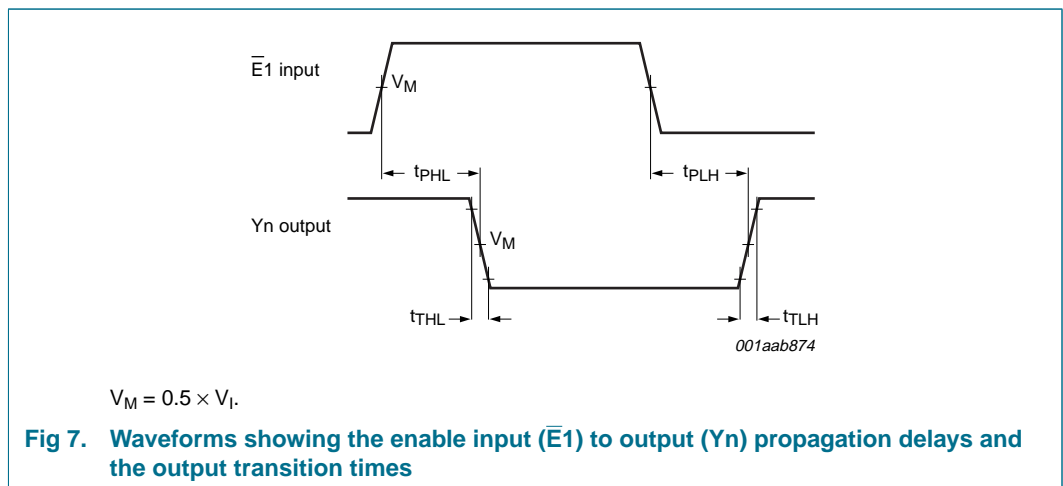
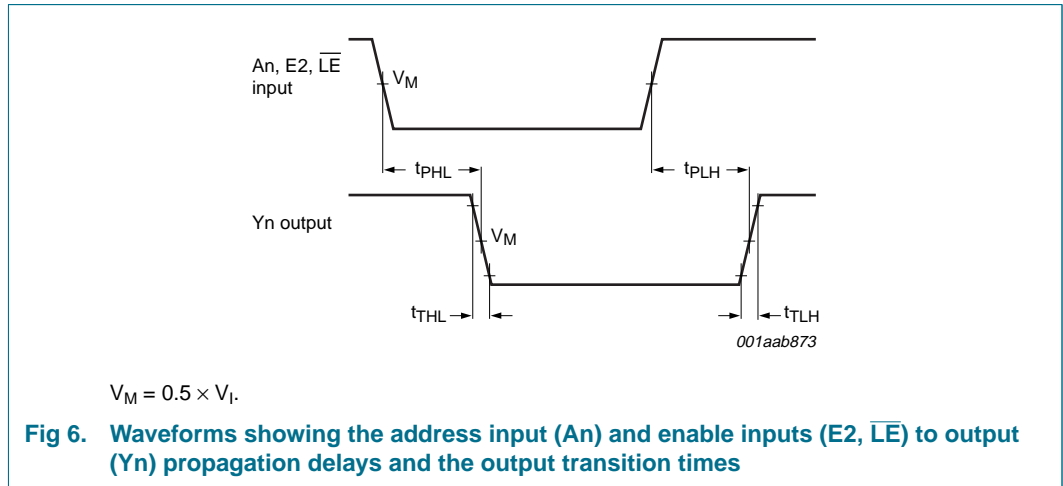

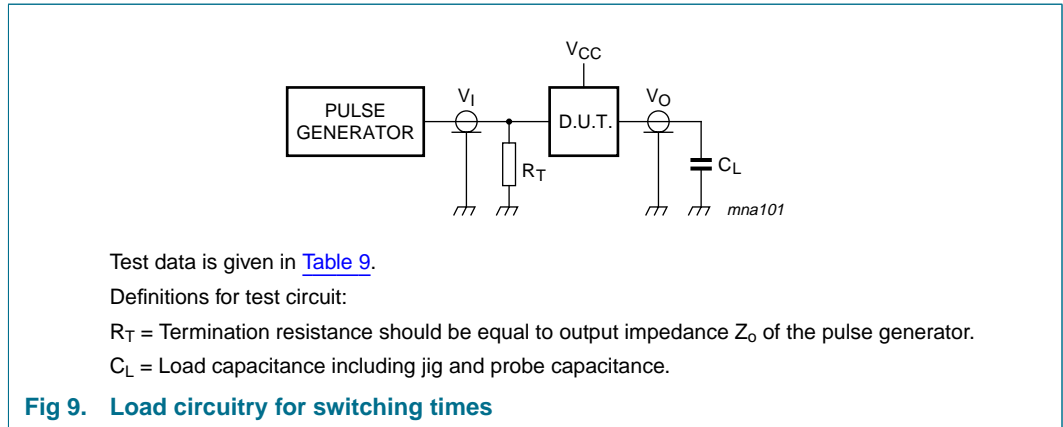
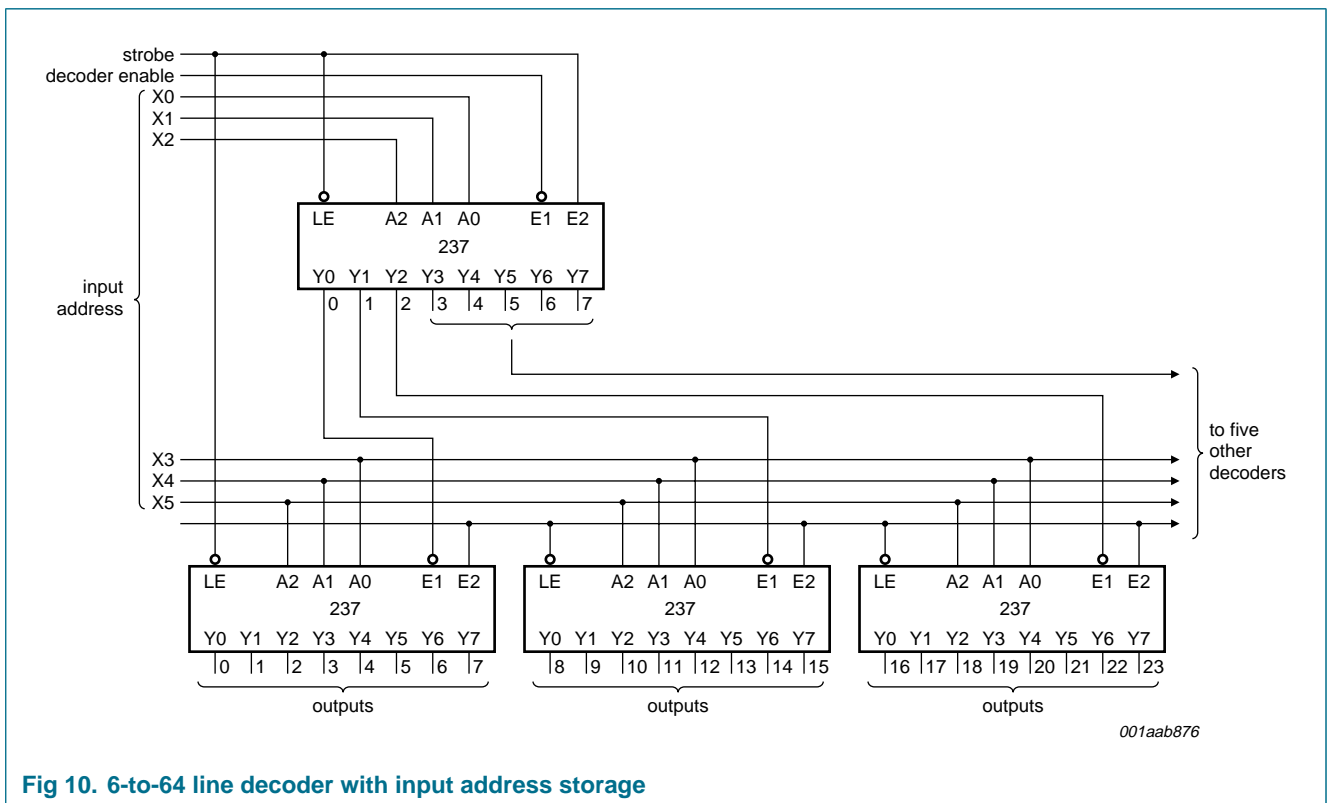

Table 9: Test data

Supply	Input	Load
V_{CC}	V_I	C_L
2.0 V	V_{CC}	6 ns
4.5 V	V_{CC}	6 ns
6.0 V	V_{CC}	6 ns
5.0 V	V_{CC}	6 ns
		50 pF
		15 pF

13. Application information



14. Package outline

DIP16: plastic dual in-line package; 16 leads (300 mil)

SOT38-4

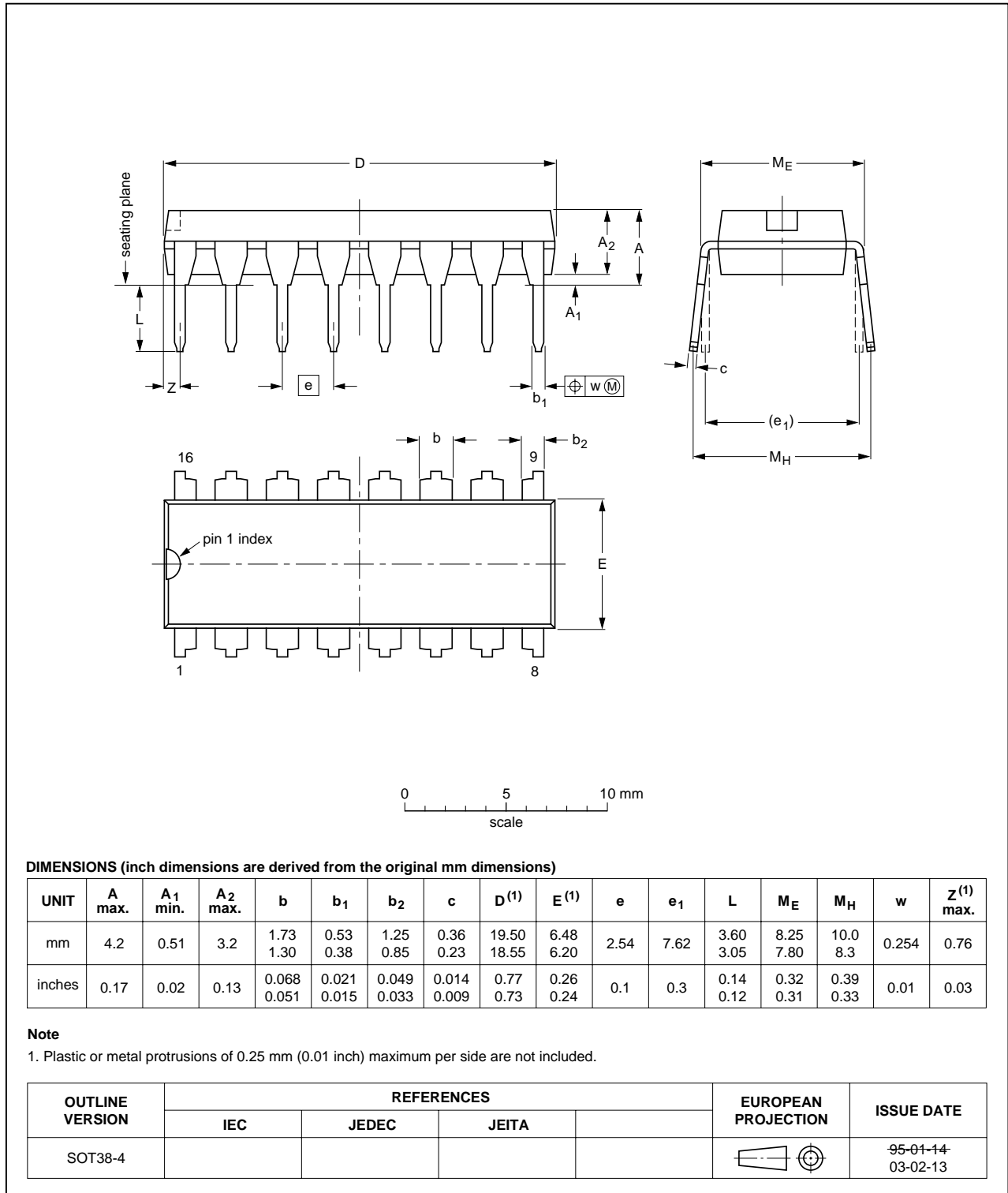

Fig 11. Package outline SOT38-4 (DIP16)

SO16: plastic small outline package; 16 leads; body width 3.9 mm

SOT109-1

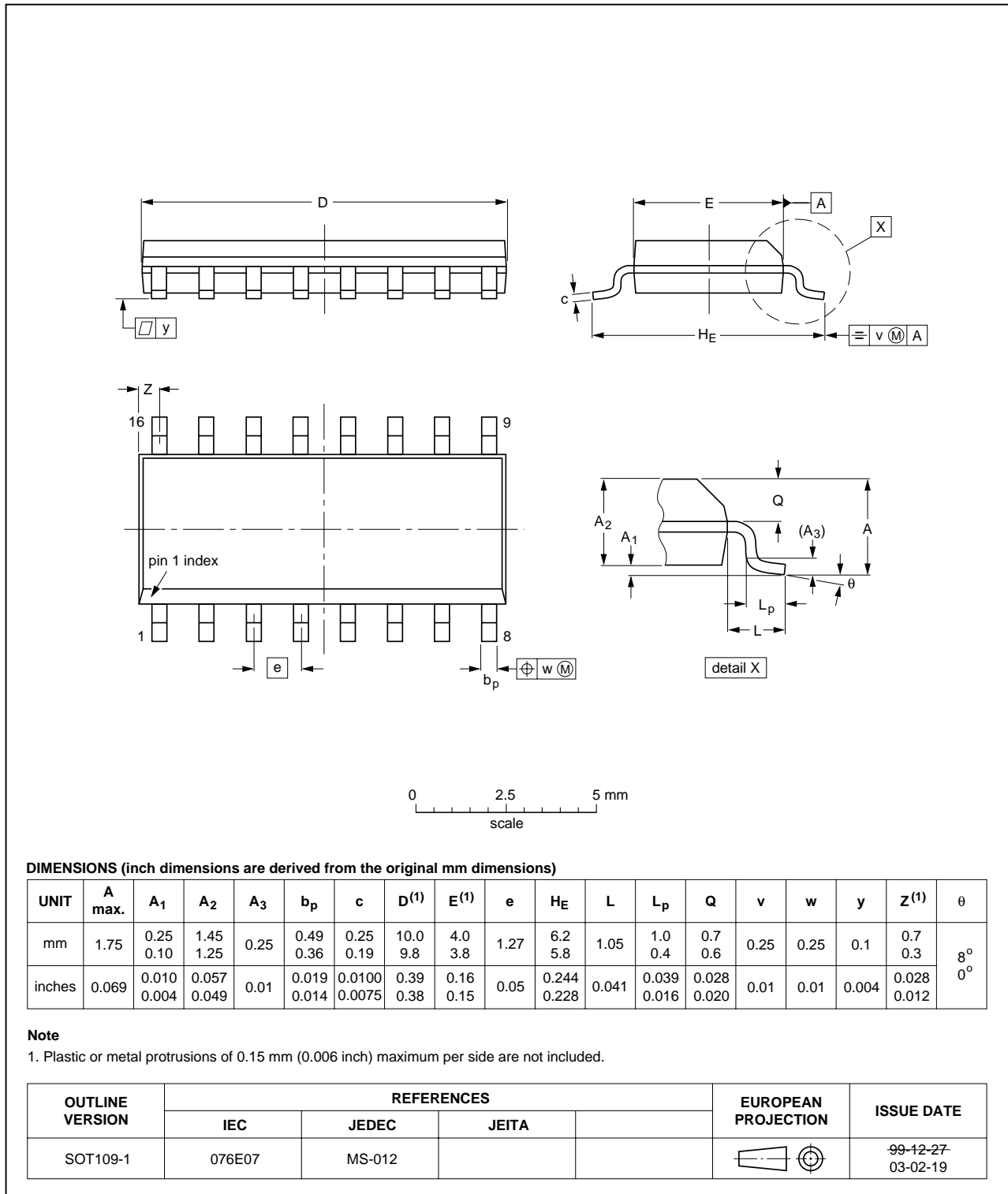

Fig 12. Package outline SOT109-1 (SO16)

SSOP16: plastic shrink small outline package; 16 leads; body width 5.3 mm

SOT338-1

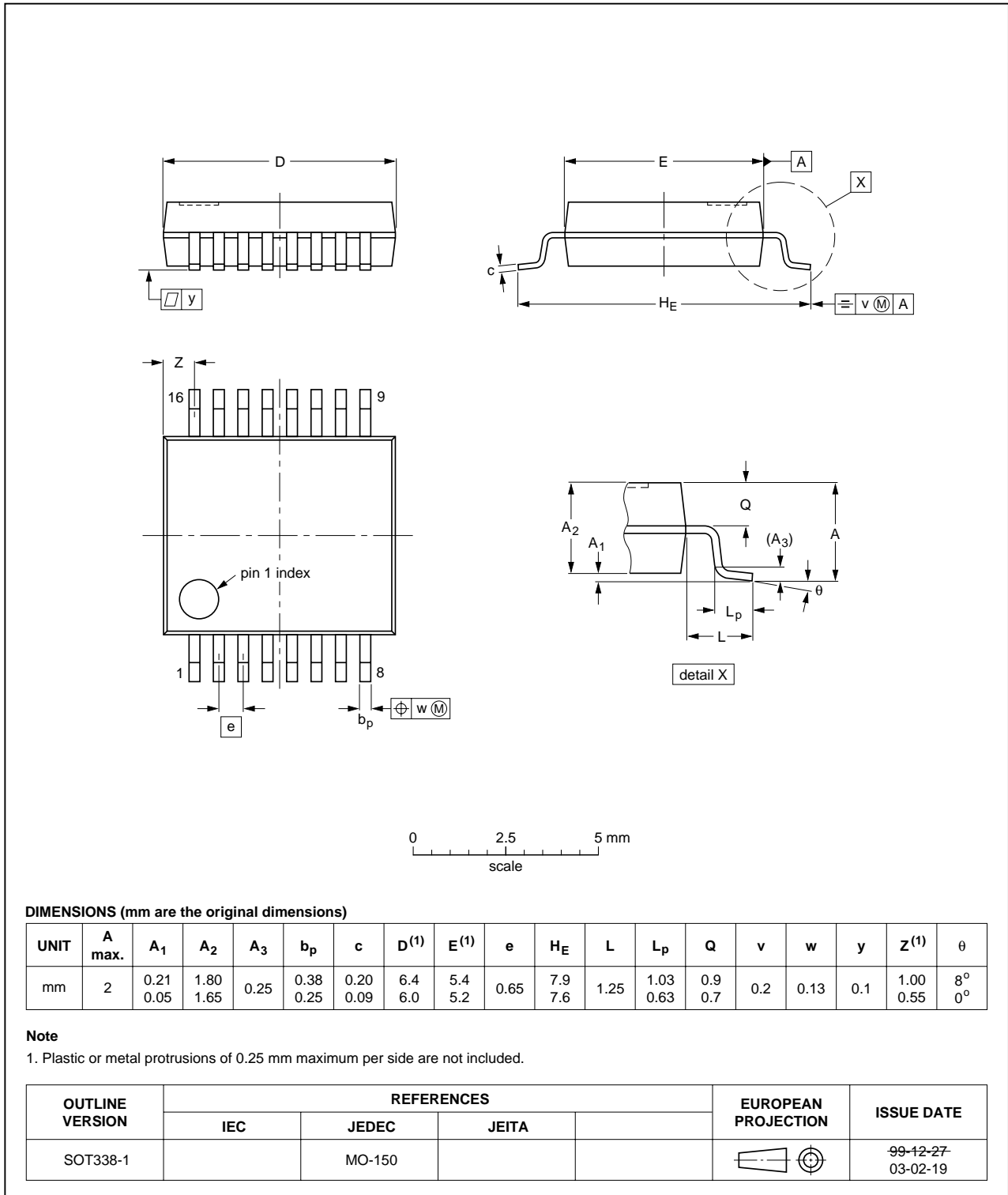

Fig 13. Package outline SOT338-1 (SSOP16)

15. Revision history

Table 10: Revision history

Document ID	Release date	Data sheet status	Change notice	Doc. number	Supersedes
74HC237_3	20041112	Product data sheet	-	9397 750 13807	74HC_HCT237_CNV_2
Modifications:					
					<ul style="list-style-type: none">• The format of this data sheet has been redesigned to comply with the current presentation and information standard of Philips Semiconductors.• Removed type number 74HCT237.• Inserted family specification.
74HC_HCT237_CNV_2	19970828	Product specification	-	-	74HC_HCT237_1
74HC_HCT237_1	19901201	Product specification	-	-	-

16. Data sheet status

Level	Data sheet status ^[1]	Product status ^[2] ^[3]	Definition
I	Objective data	Development	This data sheet contains data from the objective specification for product development. Philips Semiconductors reserves the right to change the specification in any manner without notice.
II	Preliminary data	Qualification	This data sheet contains data from the preliminary specification. Supplementary data will be published at a later date. Philips Semiconductors reserves the right to change the specification without notice, in order to improve the design and supply the best possible product.
III	Product data	Production	This data sheet contains data from the product specification. Philips Semiconductors reserves the right to make changes at any time in order to improve the design, manufacturing and supply. Relevant changes will be communicated via a Customer Product/Process Change Notification (CPCN).

[1] Please consult the most recently issued data sheet before initiating or completing a design.

[2] The product status of the device(s) described in this data sheet may have changed since this data sheet was published. The latest information is available on the Internet at URL <http://www.semiconductors.philips.com>.

[3] For data sheets describing multiple type numbers, the highest-level product status determines the data sheet status.

17. Definitions

Short-form specification — The data in a short-form specification is extracted from a full data sheet with the same type number and title. For detailed information see the relevant data sheet or data handbook.

Limiting values definition — Limiting values given are in accordance with the Absolute Maximum Rating System (IEC 60134). Stress above one or more of the limiting values may cause permanent damage to the device. These are stress ratings only and operation of the device at these or at any other conditions above those given in the Characteristics sections of the specification is not implied. Exposure to limiting values for extended periods may affect device reliability.

Application information — Applications that are described herein for any of these products are for illustrative purposes only. Philips Semiconductors make no representation or warranty that such applications will be suitable for the specified use without further testing or modification.

18. Disclaimers

Life support — These products are not designed for use in life support appliances, devices, or systems where malfunction of these products can reasonably be expected to result in personal injury. Philips Semiconductors customers using or selling these products for use in such applications do so at their own risk and agree to fully indemnify Philips Semiconductors for any damages resulting from such application.

Right to make changes — Philips Semiconductors reserves the right to make changes in the products - including circuits, standard cells, and/or software - described or contained herein in order to improve design and/or performance. When the product is in full production (status 'Production'), relevant changes will be communicated via a Customer Product/Process Change Notification (CPCN). Philips Semiconductors assumes no responsibility or liability for the use of any of these products, conveys no license or title under any patent, copyright, or mask work right to these products, and makes no representations or warranties that these products are free from patent, copyright, or mask work right infringement, unless otherwise specified.

19. Contact information

For additional information, please visit: <http://www.semiconductors.philips.com>

For sales office addresses, send an email to: sales.addresses@www.semiconductors.philips.com

20. Contents

1	General description	1
2	Features	1
3	Quick reference data	2
4	Ordering information	2
5	Functional diagram	3
6	Pinning information	4
6.1	Pinning	4
6.2	Pin description	5
7	Functional description	5
7.1	Function table	5
8	Limiting values	6
9	Recommended operating conditions	6
10	Static characteristics	7
11	Dynamic characteristics	9
12	Waveforms	12
13	Application information	13
14	Package outline	14
15	Revision history	17
16	Data sheet status	18
17	Definitions	18
18	Disclaimers	18
19	Contact information	18



© Koninklijke Philips Electronics N.V. 2004

All rights are reserved. Reproduction in whole or in part is prohibited without the prior written consent of the copyright owner. The information presented in this document does not form part of any quotation or contract, is believed to be accurate and reliable and may be changed without notice. No liability will be accepted by the publisher for any consequence of its use. Publication thereof does not convey nor imply any license under patent- or other industrial or intellectual property rights.

Date of release: 12 November 2004
Document number: 9397 750 13807

Published in The Netherlands