



HESTORE.HU

elektronikai alkatrész áruház

EN: This Datasheet is presented by the manufacturer.

Please visit our website for pricing and availability at www.hestore.hu.



STP60NF06 STP60NF06FP

N-CHANNEL 60V - 0.014Ω - 60A TO-220/TO-220FP
STripFET™ POWER MOSFET

TYPE	V _{DSS}	R _{DS(on)}	I _D
STP60NF06	60 V	< 0.016 Ω	60A
STP60NF06FP	60 V	< 0.016 Ω	60A

- TYPICAL R_{DS(on)} = 0.014Ω
- EXCEPTIONAL dv/dt CAPABILITY
- 100% AVALANCHE TESTED
- APPLICATION ORIENTED CHARACTERIZATION

DESCRIPTION

This Power Mosfet series realized with STMicroelectronics unique STripFET process has specifically been designed to minimize input capacitance and gate charge. It is therefore suitable as primary switch in advanced high-efficiency isolated DC-DC converters for Telecom and Computer application. It is also intended for any application with low gate charge drive requirements.

APPLICATIONS

- HIGH-EFFICIENCY DC-DC CONVERTERS
- UPS AND MOTOR CONTROL
- AUTOMOTIVE

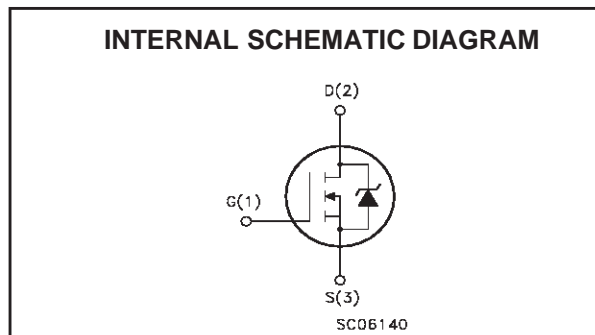
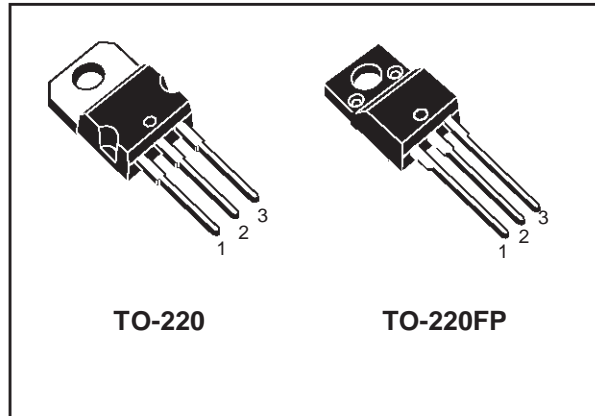

ABSOLUTE MAXIMUM RATINGS

Symbol	Parameter	Value		Unit
		STP60NF06	STP60NF06FP	
V _{DS}	Drain-source Voltage (V _{GS} = 0)	60		V
V _{DGR}	Drain-gate Voltage (R _{GS} = 20 kΩ)	60		V
V _{GS}	Gate- source Voltage	± 20		V
I _D	Drain Current (continuous) at T _C = 25°C	60	37	A
I _D	Drain Current (continuous) at T _C = 100°C	42	26	A
I _{DM} (1)	Drain Current (pulsed)	240	148	A
P _{TOT}	Total Dissipation at T _C = 25°C	110	42	W
	Derating Factor	0.73	0.28	W/°C
dv/dt (1)	Peak Diode Recovery voltage slope	4		V/ns
V _{ISO}	Insulation Withstand Voltage (DC)	--	2500	V
T _{stg}	Storage Temperature	-65 to 175		°C
T _j	Max. Operating Junction Temperature			

(●) Pulse width limited by safe operating area

(1) I_{SD} ≤ 60A, di/dt ≤ 400 A/μs, V_{DD} ≤ 24V, T_j ≤ T_{jMAX}

STP60NF06 - STP60NF06FP

THERMAL DATA

			TO-220	TO-220FP	
Rthj-case	Thermal Resistance Junction-case	Max	1.36	3.57	°C/W
Rthj-amb	Thermal Resistance Junction-ambient	Max	62.5		°C/W
T _l	Maximum Lead Temperature For Soldering Purpose		300		°C

AVALANCHE CHARACTERISTICS

Symbol	Parameter	Max Value	Unit
I _{AR}	Avalanche Current, Repetitive or Not-Repetitive (pulse width limited by T _j max)	30	A
E _{AS}	Single Pulse Avalanche Energy (starting T _j = 25 °C, I _D = I _{AR} , V _{DD} = 30 V)	360	mJ

ELECTRICAL CHARACTERISTICS (TCASE = 25 °C UNLESS OTHERWISE SPECIFIED)

OFF

Symbol	Parameter	Test Conditions	Min.	Typ.	Max.	Unit
V _{(BR)DSS}	Drain-source Breakdown Voltage	I _D = 250 μA, V _{GS} = 0	60			V
I _{DSS}	Zero Gate Voltage Drain Current (V _{GS} = 0)	V _{DS} = Max Rating V _{DS} = Max Rating, T _C = 125 °C			1 10	μA μA
I _{GSS}	Gate-body Leakage Current (V _{DS} = 0)	V _{GS} = ± 20V			±100	nA

ON (1)

Symbol	Parameter	Test Conditions	Min.	Typ.	Max.	Unit
V _{GS(th)}	Gate Threshold Voltage	V _{DS} = V _{GS} , I _D = 250μA	2		4	V
R _{DS(on)}	Static Drain-source On Resistance	V _{GS} = 10V, I _D = 30 A		0.014	0.016	Ω

DYNAMIC

Symbol	Parameter	Test Conditions	Min.	Typ.	Max.	Unit
g _{fs} (1)	Forward Transconductance	V _{DS} = 15V, I _D = 30 A		20		S
C _{iss}	Input Capacitance	V _{DS} = 25V, f = 1 MHz, V _{GS} = 0		1810		pF
C _{oss}	Output Capacitance			360		pF
C _{rss}	Reverse Transfer Capacitance			125		pF

ELECTRICAL CHARACTERISTICS (CONTINUED)

SWITCHING ON

Symbol	Parameter	Test Conditions	Min.	Typ.	Max.	Unit
$t_{d(on)}$	Turn-on Delay Time	$V_{DD} = 30\text{ V}, I_D = 30\text{ A}$		16		ns
t_r	Rise Time	$R_G = 4.7\Omega, V_{GS} = 10\text{ V}$ (see test circuit, Figure 3)		108		ns
Q_g	Total Gate Charge	$V_{DD} = 48\text{ V}, I_D = 60\text{ A}, V_{GS} = 10\text{ V}$		49	66	nC
Q_{gs}	Gate-Source Charge			18		nC
Q_{gd}	Gate-Drain Charge			14		nC

SWITCHING OFF

Symbol	Parameter	Test Conditions	Min.	Typ.	Max.	Unit
$t_{d(off)}$	Turn-off-Delay Time	$V_{DD} = 30\text{ V}, I_D = 30\text{ A},$		43		ns
t_f	Fall Time	$R_G = 4.7\Omega, V_{GS} = 10\text{ V}$ (see test circuit, Figure 3)		20		ns
$t_{d(off)}$	Off-voltage Rise Time	$V_{clamp} = 48\text{ V}, I_D = 60\text{ A}$		40		ns
t_f	Fall Time	$R_G = 4.7\Omega, V_{GS} = 10\text{ V}$		12		ns
t_c	Cross-over Time	(see test circuit, Figure 3)		21		ns

SOURCE DRAIN DIODE

Symbol	Parameter	Test Conditions	Min.	Typ.	Max.	Unit
I_{SD}	Source-drain Current				60	A
$I_{SDM(2)}$	Source-drain Current (pulsed)				240	A
$V_{SD(1)}$	Forward On Voltage	$I_{SD} = 60\text{ A}, V_{GS} = 0$			1.3	V
t_{rr}	Reverse Recovery Time	$I_{SD} = 60\text{ A}, di/dt = 100\text{ A}/\mu\text{s},$		73		ns
Q_{rr}	Reverse Recovery Charge	$V_{DD} = 25\text{ V}, T_j = 150^\circ\text{C}$		182		nC
I_{RRM}	Reverse Recovery Current	(see test circuit, Figure 5)		5		A

Note: 1. Pulsed: Pulse duration = 300 μs , duty cycle 1.5 %.
 2. Pulse width limited by safe operating area.

Safe Operating Area for TO-220

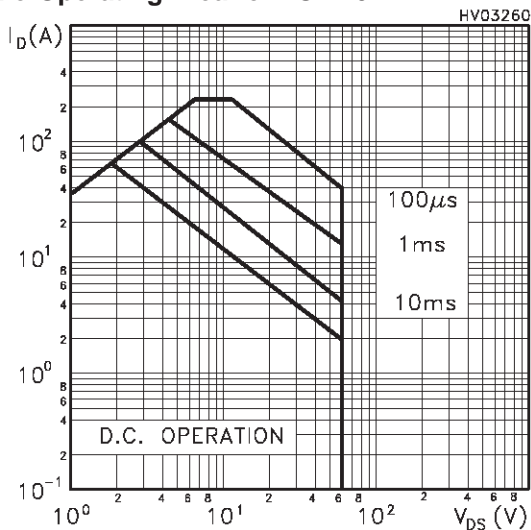

Safe Operating Area for TO-220FP

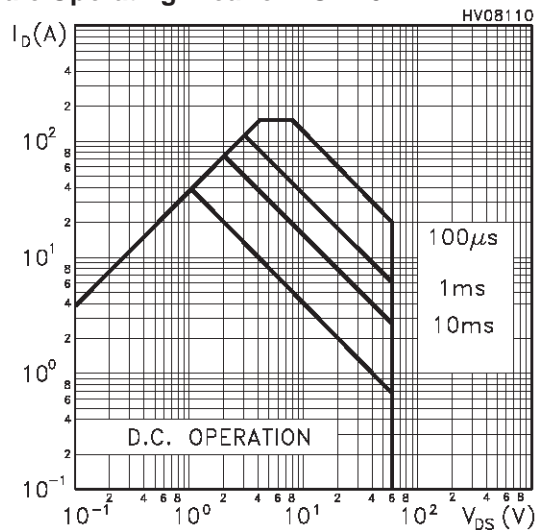

Thermal Impedance for TO-220

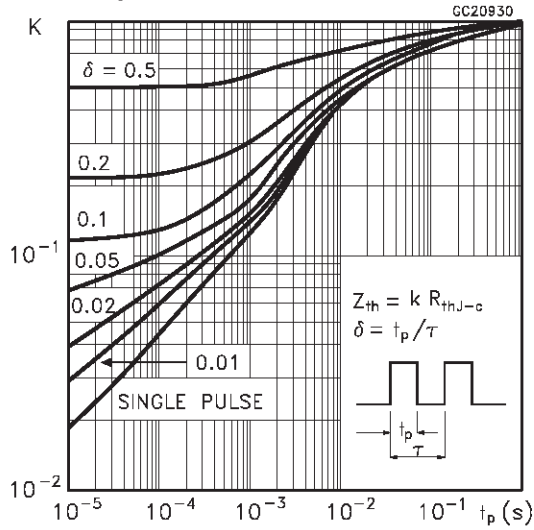

Thermal Impedance for TO-220FP

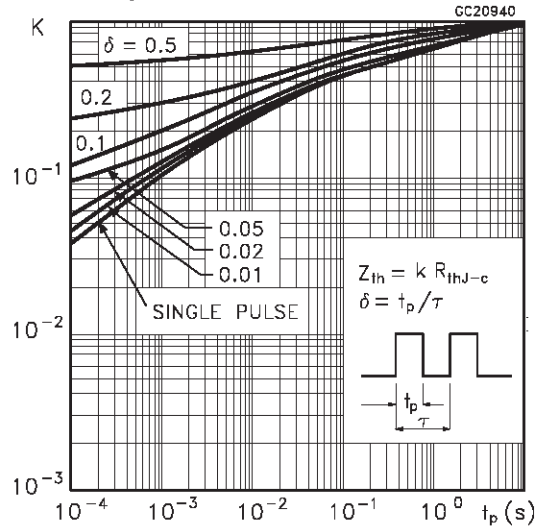

Output Characteristics

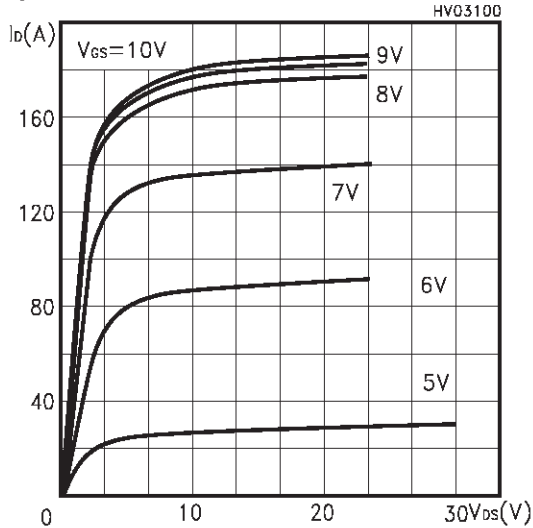

Transfer Characteristics

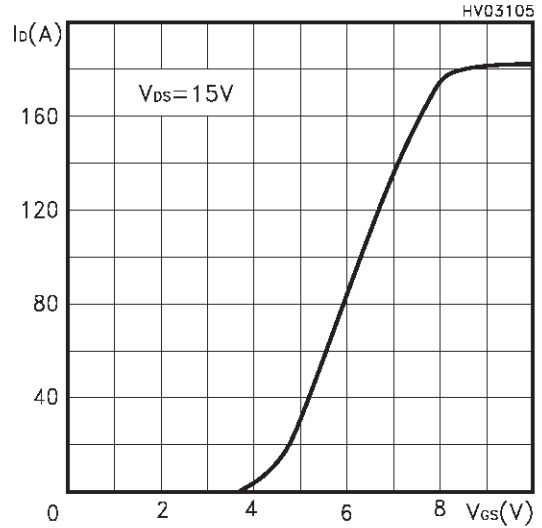

Transconductance

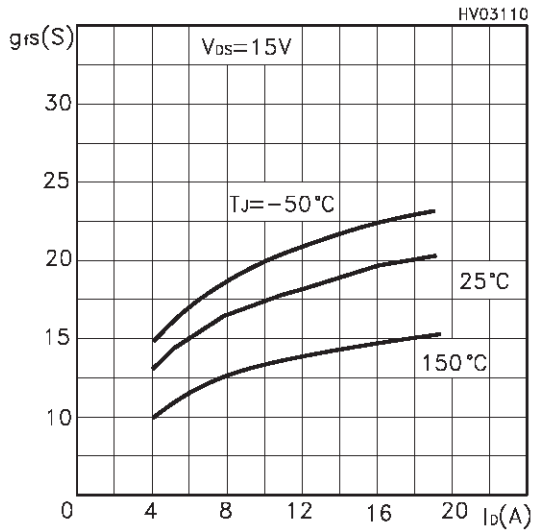

Static Drain-source On Resistance

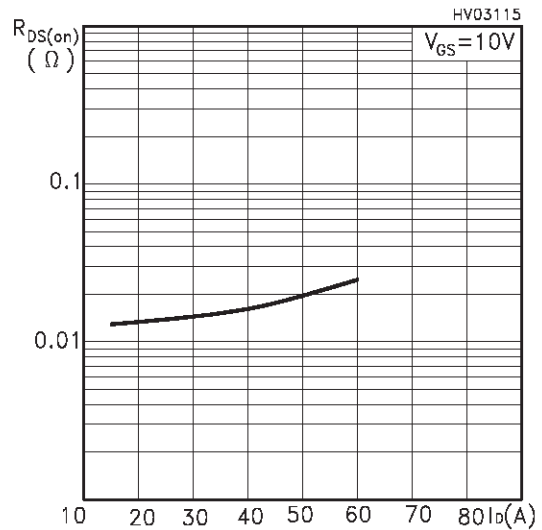

Gate Charge vs Gate-source Voltage

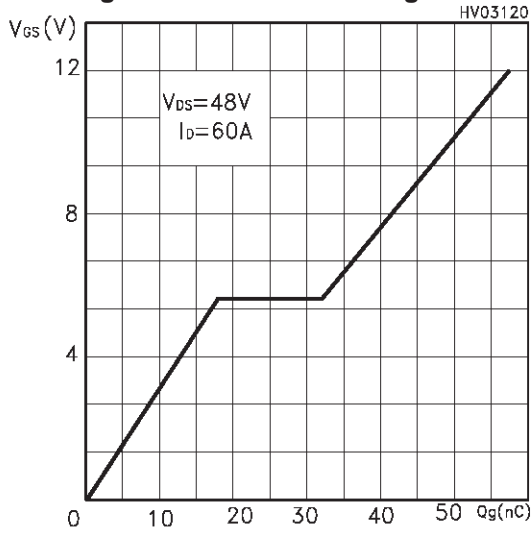

Capacitance Variations

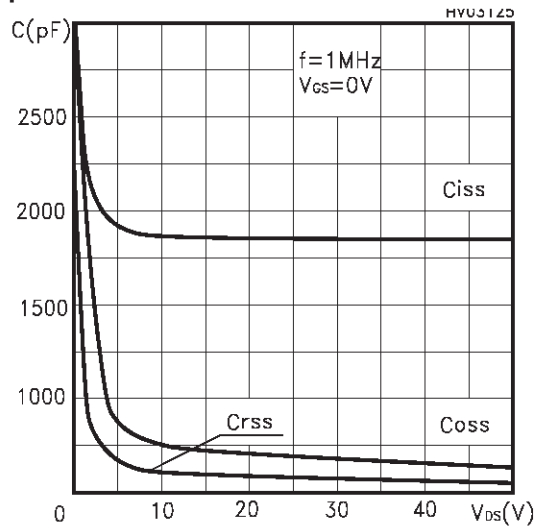

Normalized Gate Threshold Voltage vs Temperature

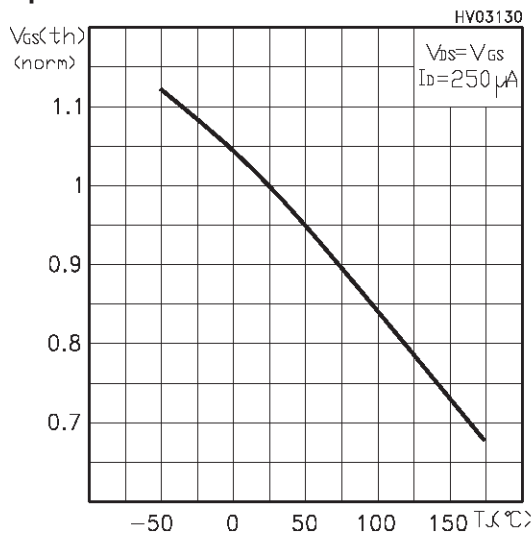

Normalized On Resistance vs Temperature

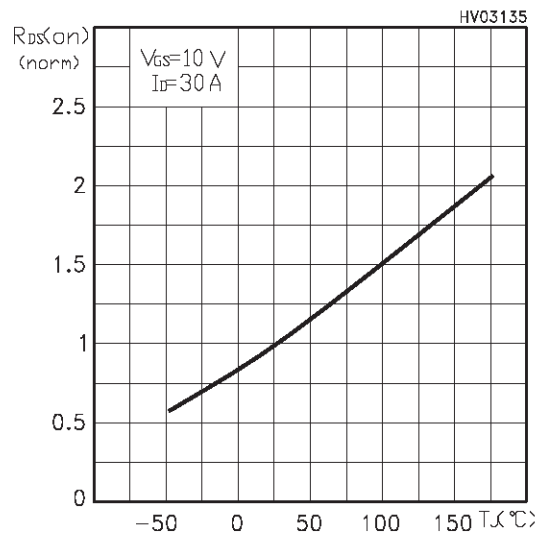

Source-drain Diode Forward Characteristics

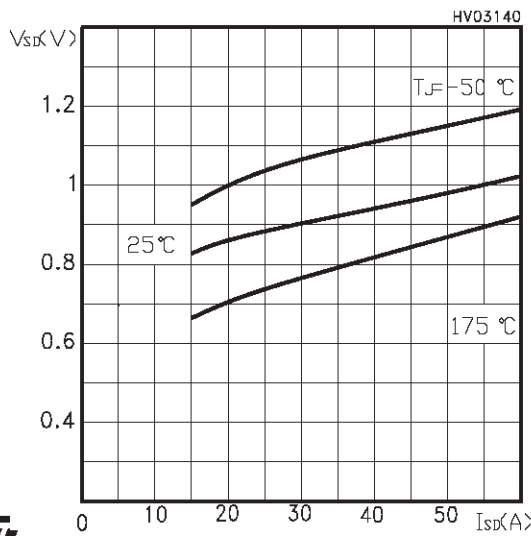

Fig. 1: Unclamped Inductive Load Test Circuit

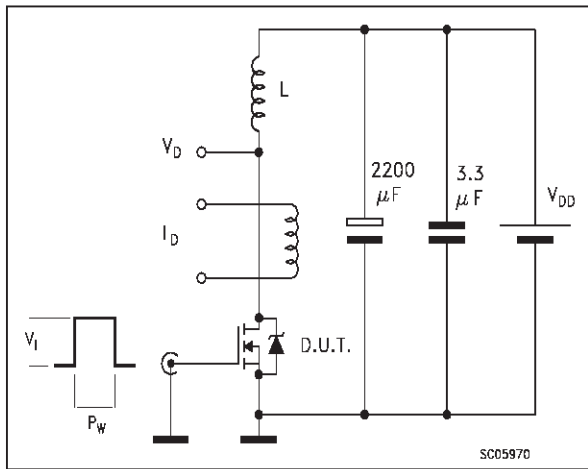

Fig. 2: Unclamped Inductive Waveform

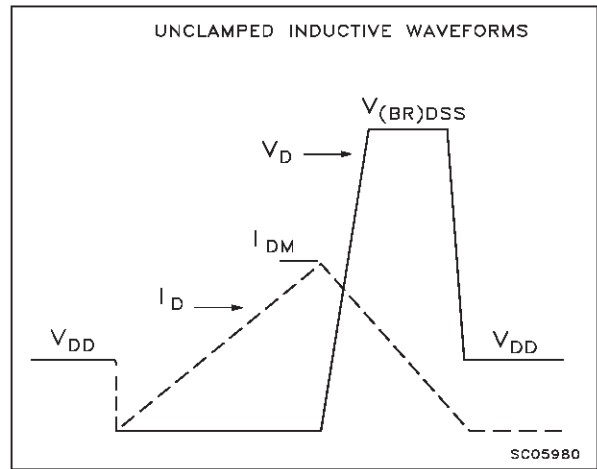

Fig. 3: Switching Times Test Circuit For Resistive Load

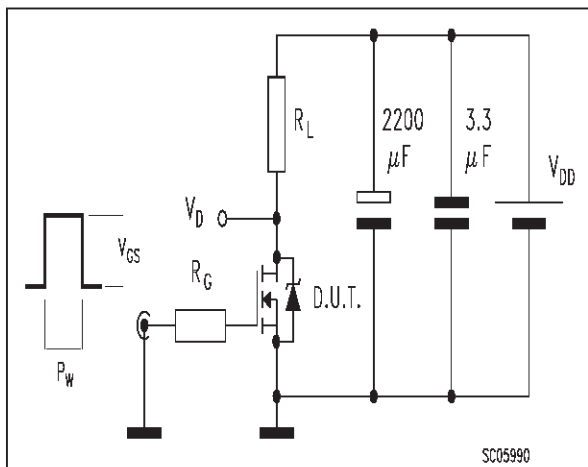

Fig. 4: Gate Charge test Circuit

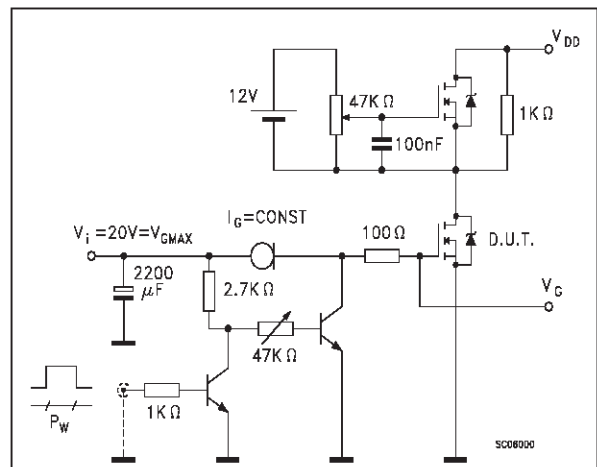
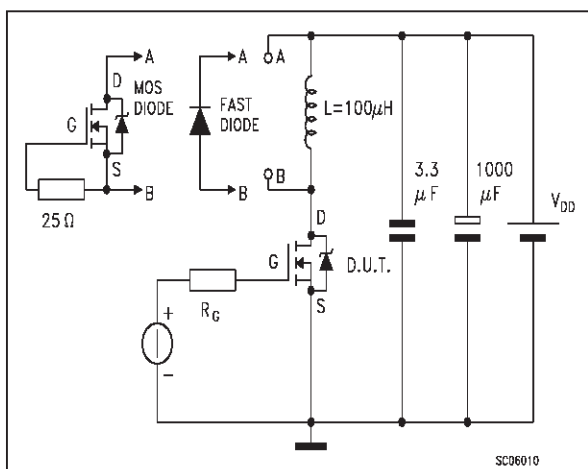

Fig. 5: Test Circuit For Inductive Load Switching And Diode Recovery Times



TO-220 MECHANICAL DATA

DIM.	mm			inch		
	MIN.	TYP.	MAX.	MIN.	TYP.	MAX.
A	4.40		4.60	0.173		0.181
C	1.23		1.32	0.048		0.051
D	2.40		2.72	0.094		0.107
D1		1.27			0.050	
E	0.49		0.70	0.019		0.027
F	0.61		0.88	0.024		0.034
F1	1.14		1.70	0.044		0.067
F2	1.14		1.70	0.044		0.067
G	4.95		5.15	0.194		0.203
G1	2.4		2.7	0.094		0.106
H2	10.0		10.40	0.393		0.409
L2		16.4			0.645	
L4	13.0		14.0	0.511		0.551
L5	2.65		2.95	0.104		0.116
L6	15.25		15.75	0.600		0.620
L7	6.2		6.6	0.244		0.260
L9	3.5		3.93	0.137		0.154
DIA.	3.75		3.85	0.147		0.151

