



HESTORE.HU

elektronikai alkatrész áruház

EN: This Datasheet is presented by the manufacturer.

Please visit our website for pricing and availability at www.hestore.hu.



JSL-303 Series(3mm round ultra brightness LED lamp)

Absolute Maximum Ratings at Ta=25°C

Parameter	Symbol	Rating	Unit
Forward Current	I _F	25	mA
Power Dissipation	P _d	60	mW
Reverse Voltage	V _R	5	V
Peak Forward Current (Duty 1/10 @1KHZ)	I _{PF}	150	mA
Operation Temperature	T _{OPR}	-40 to +80	°C
Storage Temperature	T _{STG}	-40 to +85	°C

Package Dimensions:

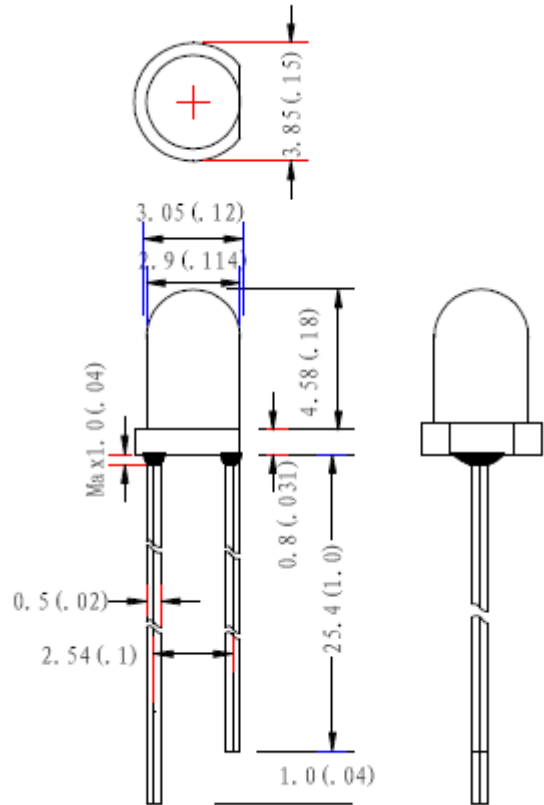

Features:

1. Standard brightness.
2. Choice of various viewing angles
3. IC compatible /Low current capability
4. Long life solid state reliability.

Description:

1. These LED lamps are available with a choice of different colors, light intensities, epoxy color, etc
2. General application for indication, illumination, etc

Products List

Part Number	Dice material And color	Lens color	Peak Wavelength	V _f (V) Typ	I _v (mcd)		Viewing Angle 2 θ 1/2
					Min	Typ	
JSL-303URC-S	AlGaInP /Ultra Red	Water Clear	625nm	2.0	800	1500	25°
JSL-303URC-U	AlGaInP /Ultra Red	Water Clear	625nm	2.0	1500	3000	25°
JSL-303UYC-S	AlGaInP/ Ultra Yellow	Water Clear	590nm	2.0	800	1200	25°
JSL-303UYC-U	AlGaInP/ Ultra Yellow	Water Clear	590nm	2.0	1500	3000	25°
JSL-303UGC	AlGaInP /Ultra Green	Water Clear	574nm	2.0	350	500	25°
JSL-303UAC	AlGaInP /Ultra Amber	Water Clear	610nm	2.0	800	1500	25°
JSL-303UBC	InGaIn/ Ultra Blue	Water Clear	470nm	3.5	1200	2000	25°
JSL-303BGC	InGaIn/ Bluish Green	Water Clear	505nm	3.5	2000	4000	25°
JSL-303PGC	InGaIn/ Pure Green	Water Clear	525nm	3.5	3000	5000	25°
JSL-303UWC	InGaIn/ Ultra White	Water Clear	5500K	3.5	2000	4500	25°
JSL-303WWC	InGaIn/ warm White	Water Clear	3300K	3.5	2000	4000	25°
JSL-303VC	InGaIn/ Super Violet	Water Clear	400nm	3.5	150	300	25°