



HESTORE.HU

elektronikai alkatrész áruház

EN: This Datasheet is presented by the manufacturer.

Please visit our website for pricing and availability at www.hestore.hu.

High Input Voltage, Adjustable 3-Terminal Linear Regulator

Features

- ▶ 13.2 - 450V input voltage range
- ▶ Adjustable 1.20 - 440V output regulation
- ▶ 5% output voltage tolerance
- ▶ Output current limiting
- ▶ 10 μ A typical ADJ current
- ▶ Internal junction temperature limiting

Applications

- ▶ Off-line SMPS startup circuits
- ▶ Adjustable high voltage constant current source
- ▶ Industrial controls
- ▶ Motor controls
- ▶ Battery chargers
- ▶ Power supplies

General Description

The Supertex LR8 is a high voltage, low output current, adjustable linear regulator. It has a wide operating input voltage range of 13.2 - 450V. The output voltage can be adjusted from 1.20 - 440V provided that the input voltage is at least 12V greater than the output voltage. The output voltage can be adjusted by means of two external resistors R1 and R2 as shown in the typical application circuits. The LR8 regulates the voltage difference between VOUT and ADJ pins to a nominal value of 1.20V. The 1.20V is amplified by the external resistor ratio R1 and R2. An internal constant bias current of typically 10 μ A is connected to the ADJ pin. This increases V_{OUT} by a constant voltage of 10 μ A times R2.

The LR8 has current limiting and temperature limiting. The output current limit is typically 20mA and the minimum temperature limit is 125°C. An output short circuit current will therefore be limited to 20mA. When the junction temperature reaches its temperature limit, the output current and/or output voltage will decrease to keep the junction temperature from exceeding its temperature limit. For SMPS start-up circuit applications, the LR8 turns off when an external voltage greater than the output voltage of the LR8 is applied to VOUT of the LR8. To maintain stability, a bypass capacitor of 1.0 μ F or larger and a minimum DC output current of 500 μ A are required.

The device is available in TO-243AA (SOT-89), TO-252 (D-PAK), and TO-92 packages.

Typical Application Circuit

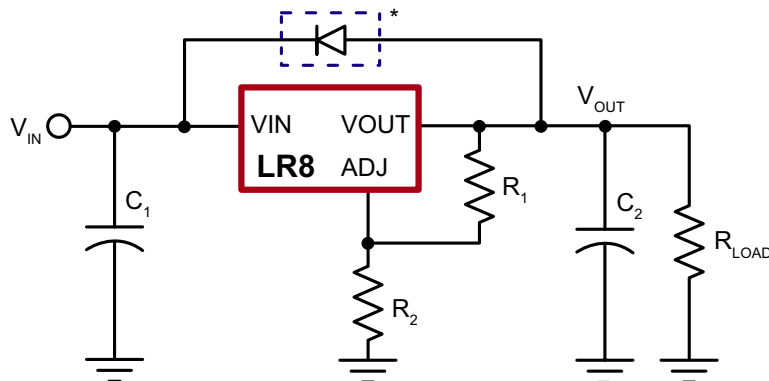

* Required for conditions where V_{IN} is less than V_{OUT}

Ordering Information

Device	Package Options		
	TO-252 (D-PAK)	TO-92	TO-243AA (SOT-89)
LR8	LR8K4-G	LR8N3-G	LR8N8-G

-G indicates package is RoHS compliant ("Green")



Absolute Maximum Ratings

Parameter	Value
V_{IN} input voltage (voltagess ref to ADJ)	-0.5V to +480V
Output voltage range	-0.5V to +470V
Operating ambient temperature range	-40°C to +85°C
Operating junction temperature range	-40°C to +125°C
Storage temperature range	-65°C to +150°C

Stresses beyond those listed under "Absolute Maximum Ratings" may cause permanent damage to the device. These are stress ratings only, and functional operation of the device at these or any other conditions beyond those indicated in the operational sections of the specifications is not implied. Exposure to absolute maximum rating conditions for extended periods may affect device reliability.

Electrical Characteristics

(Test conditions unless otherwise specified: $-40^{\circ}\text{C} < T_A < 85^{\circ}\text{C}$.)

Sym	Parameter	Min	Typ	Max	Units	Conditions
$V_{IN} - V_{OUT}$	Input to output voltage difference	12	-	450	V	---
V_{OUT}	Overall output voltage regulation	1.14	1.20	1.26	V	$13.2\text{V} < V_{IN} < 400\text{V}$, $R1 = 2.4\text{K}\Omega$, $R2 = 0$
V_{OUT}	Overall output voltage regulation	375	400	425	V	$R1 = 2.4\text{K}\Omega$, $R2 = 782\text{K}\Omega$
ΔV_{OUT}	Line regulation	-	0.003	0.01	%/V	$17\text{V} < V_{IN} < 400\text{V}$, $V_{OUT} = 5\text{V}$, $I_{OUT} = 0.5\text{mA}$
ΔV_{OUT}	Load regulation	-	1.4	3.0	%	$V_{IN} = 17\text{V}$, $V_{OUT} = 5\text{V}$, $0.5\text{mA} < I_{OUT} < 10\text{mA}$
ΔV_{OUT}	Temperature regulation	-1	-	+1	%	$V_{IN} = 17\text{V}$, $V_{OUT} = 5\text{V}$, $I_{OUT} = 10\text{mA}$, $-40^{\circ}\text{C} < T_A < 85^{\circ}\text{C}$
I_{OUT}	Output current limit	10	-	30	mA	$T_J < 85^{\circ}\text{C}$, $V_{IN} - V_{OUT} = 12\text{V}$
I_{OUT}	Output current limit	-	-	0.5	mA	$T_J > 125^{\circ}\text{C}$, $V_{IN} - V_{OUT} = 450\text{V}$

Pin Configurations



TO-252 (K4)

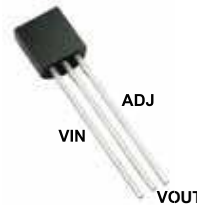

TO-92 (N3)

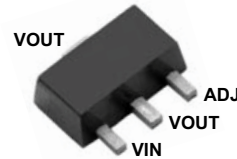

TO-243AA (SOT-89) (N8)

Product Marking

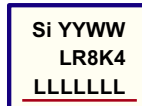

YY = Year Sealed
WW = Week Sealed
L = Lot Number
_____ = "Green" Packaging

Package may or may not include the following marks: Si or

TO-252 (K4)



Y = Last Digit of Year Sealed
W = Code for Week Sealed
L = Lot Number
_____ = "Green" Packaging

Package may or may not include the following marks: Si or

TO-92 (N3)



W = Code for Week Sealed
_____ = "Green" Packaging

Package may or may not include the following marks: Si or

TO-243AA (SOT-89) (N8)

Electrical Characteristics (cont.)

(Test conditions unless otherwise specified: $-40^{\circ}\text{C} < T_A < 85^{\circ}\text{C}$.)

Sym	Parameter	Min	Typ	Max	Units	Conditions
I_{OUT}	Minimum output current	-	0.3	0.5	mA	Includes R1 and load current
I_{ADJ}	Adjust output current	5.0	10	15	μA	---
C2	Minimum output load capacitance	1.0	-	-	μF	---
$\text{DV}_{\text{OUT}}/\text{DV}_{\text{IN}}$	Ripple rejection ratio	50	60	-	dB	120Hz, $V_{\text{OUT}} = 5\text{V}$
T_{LIMIT}	Junction temperature limit	125	-	-	$^{\circ}\text{C}$	---

Thermal Characteristics

Package	Power Dissipation @ $T_A = 25^{\circ}\text{C}$	θ_{jc} $^{\circ}\text{C}/\text{W}$	θ_{ja} $^{\circ}\text{C}/\text{W}$
TO-92	0.74W	125	170
TO-243AA	1.6W	15	78 [†]
TO-252	2.5W	6.25	50 [†]

Note:

[†] Mounted on FR4 board, 25mm x 25mm x 1.57mm.

Functional Block Diagram

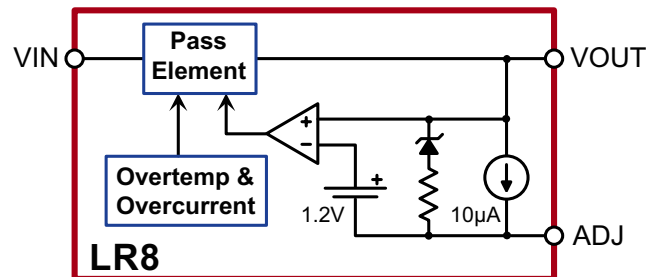

Typical Application Circuits

Figure 1: High Input Voltage, 5.0V Output Linear Regulator

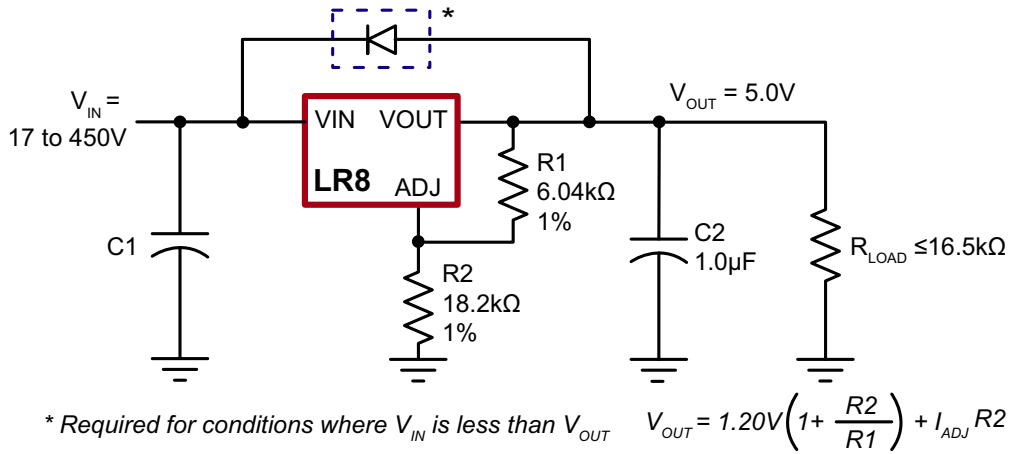

Figure 2: SMPS Start-Up Circuit

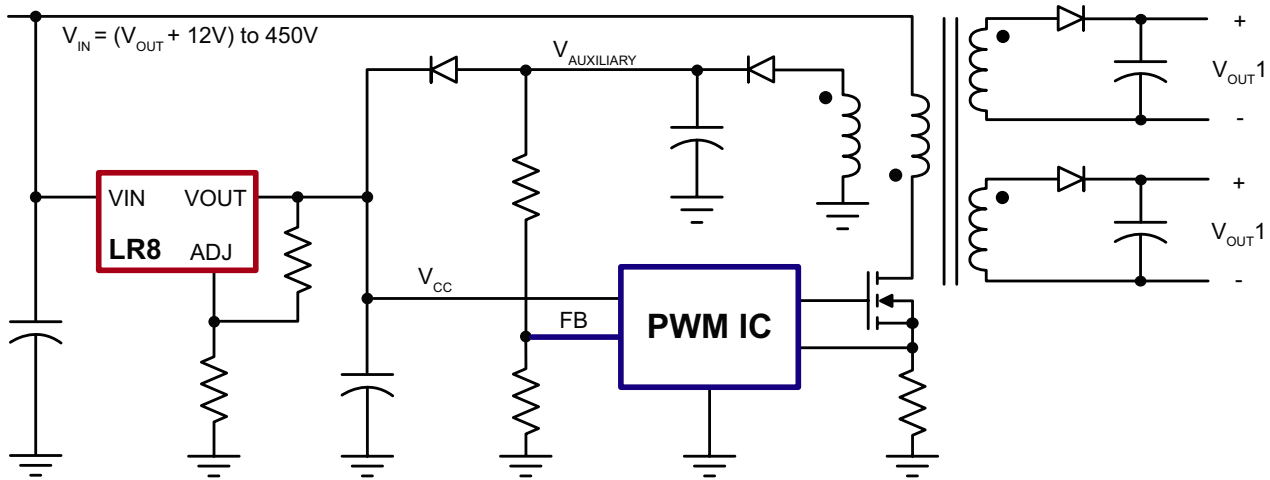
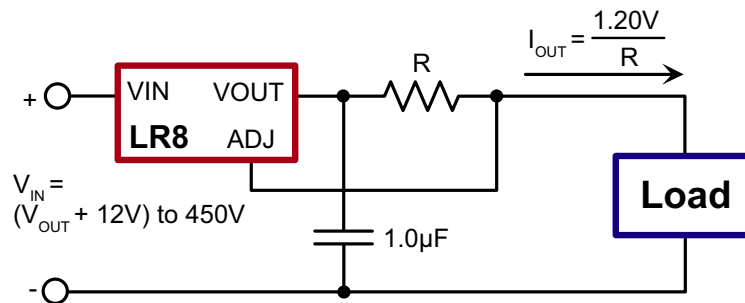
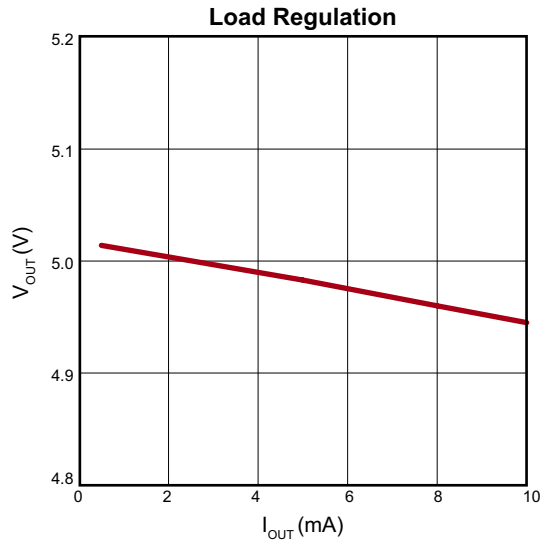
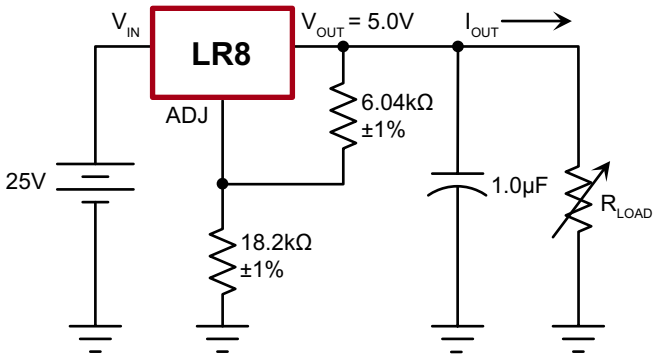
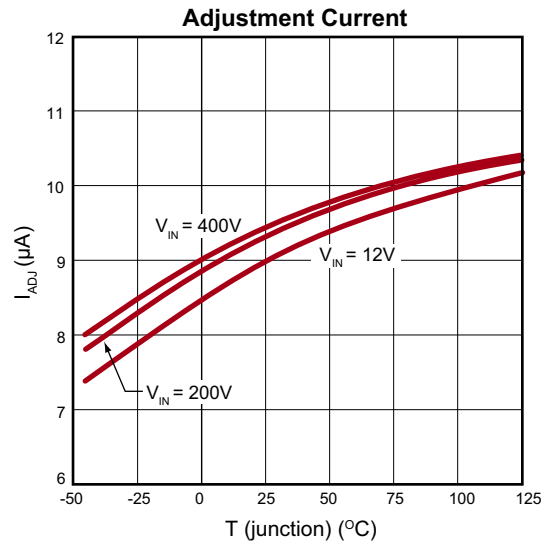
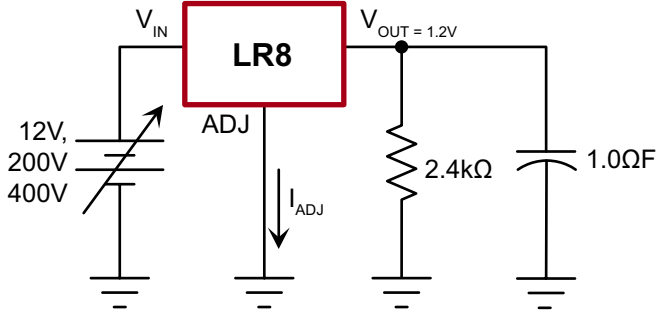
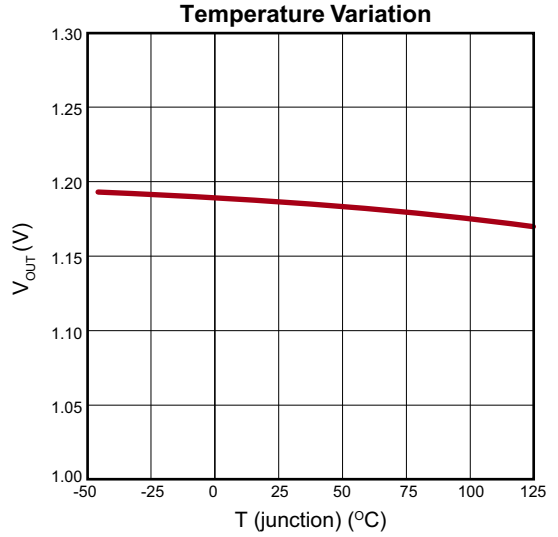
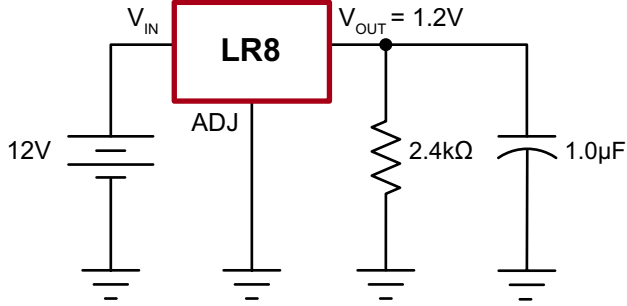

Figure 3: High Voltage Adjustable Constant Current Source



Typical Performance Curves



Typical Performance Curves (cont.)

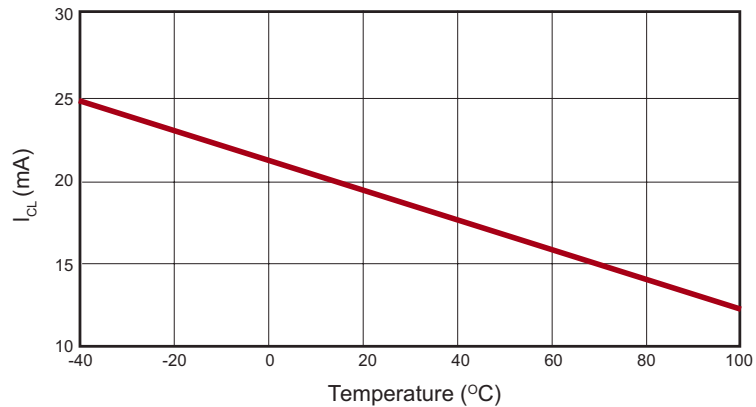
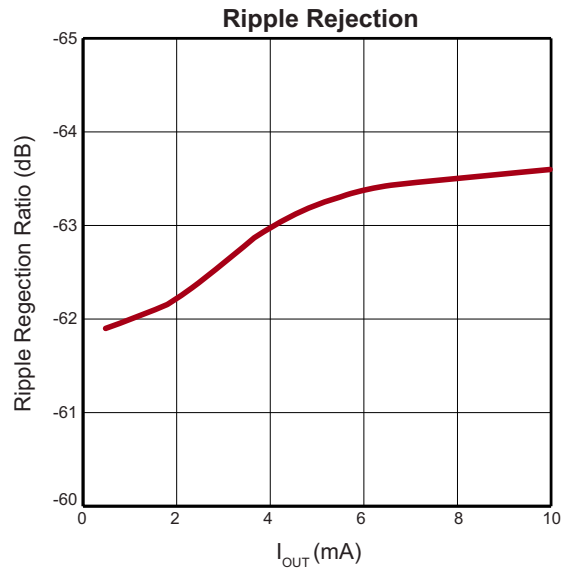
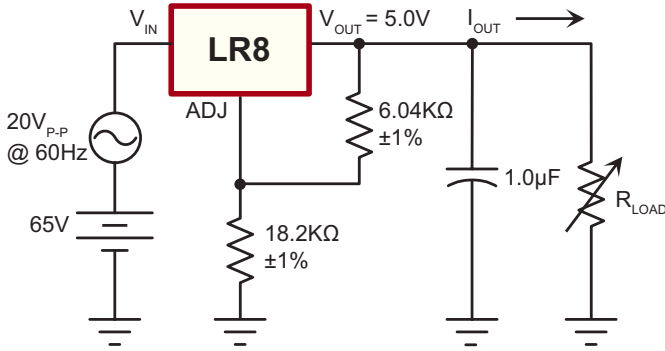
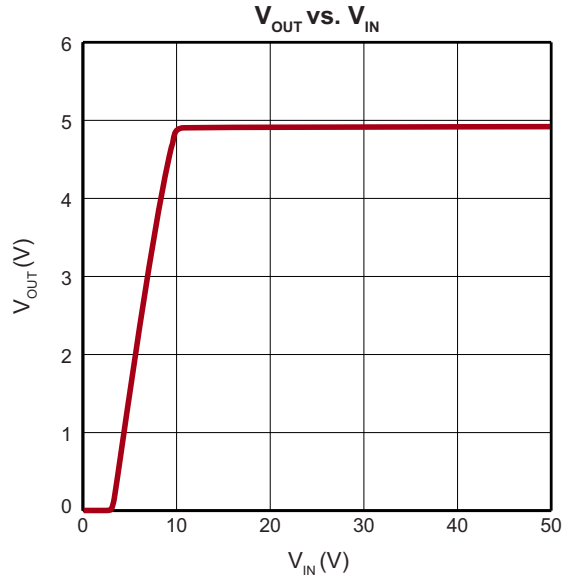
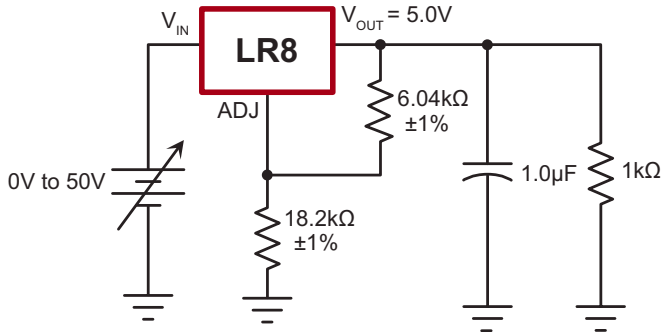

Typical Performance Curves (cont.)

Load Transient Response

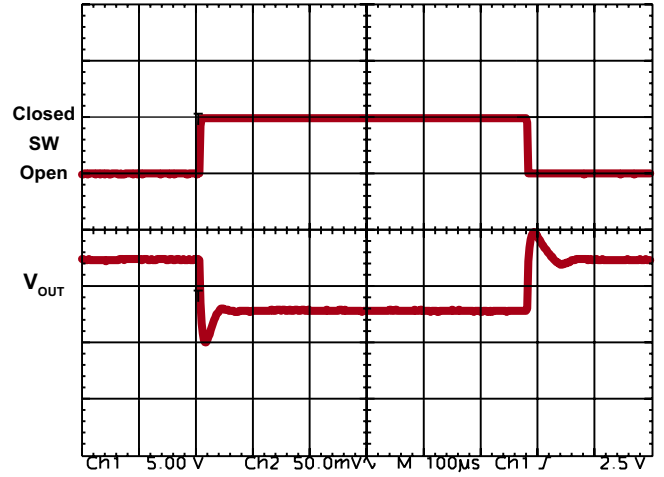
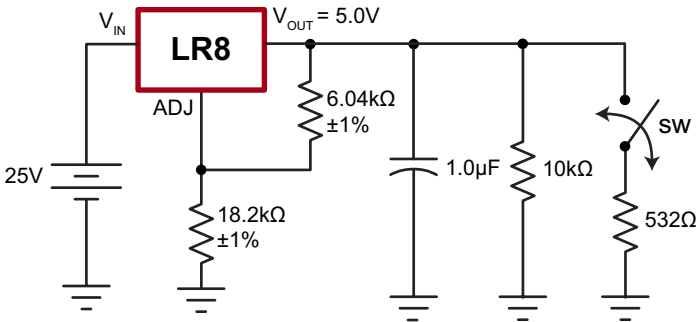

Load Transient Response

Line Transient Response

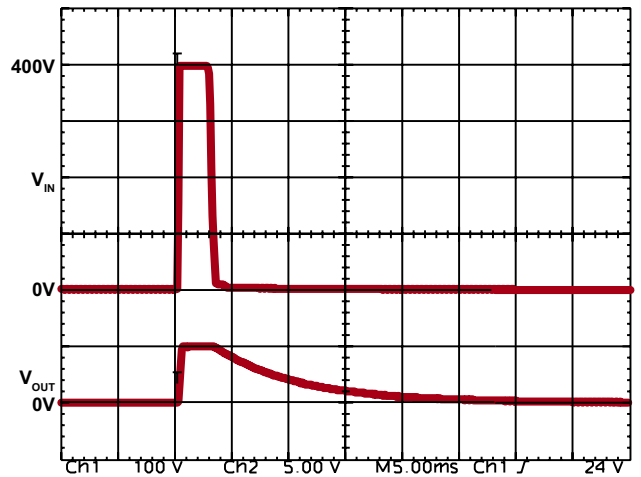
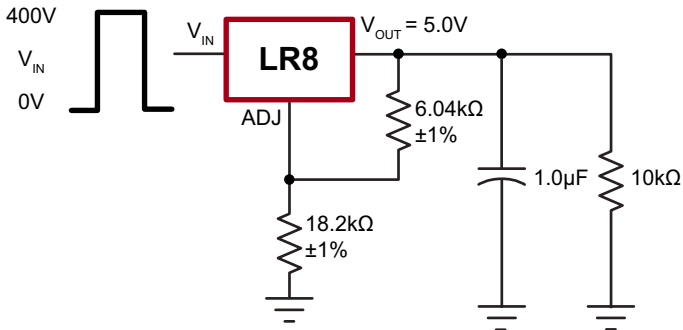

Line Transient Response

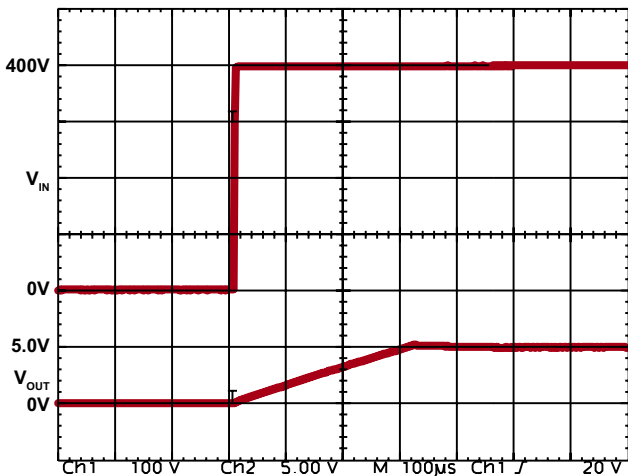

Line Power Up Transient

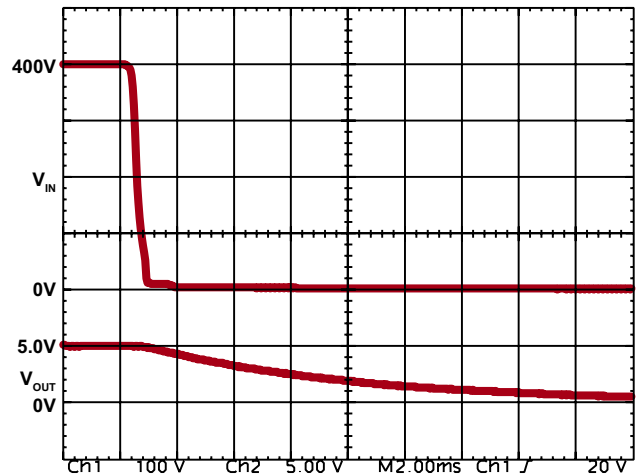

Line Power Down Transient

3-Lead TO-252 D-PAK Package Outline (K4)

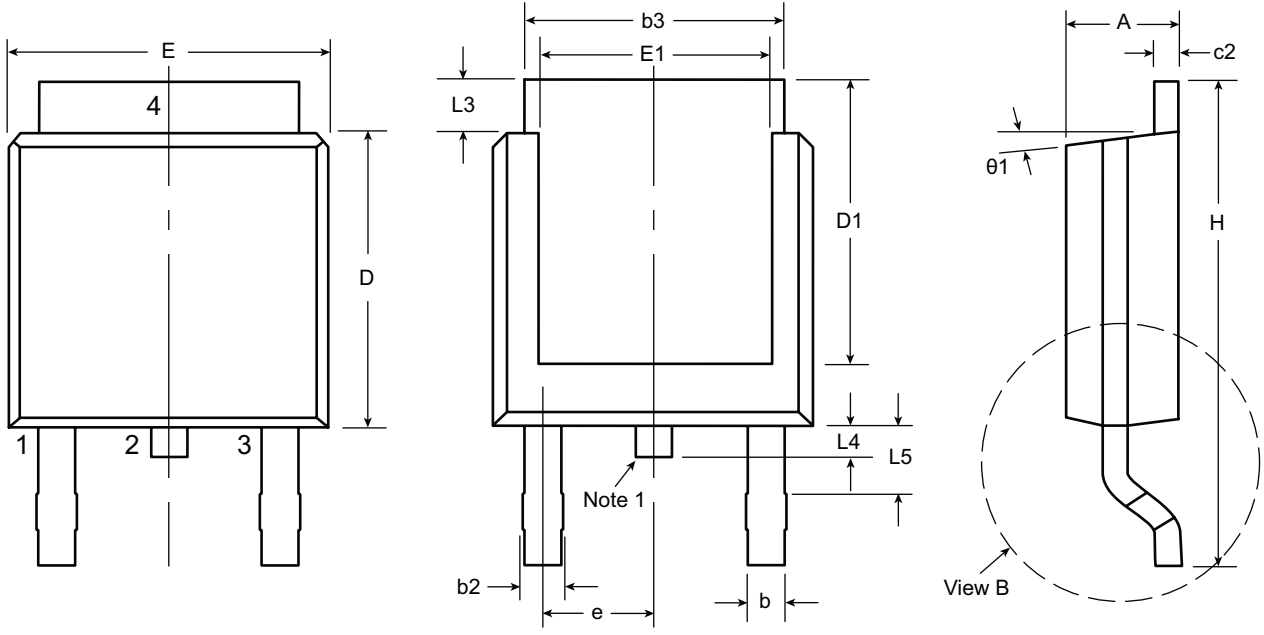

Front View

Rear View

Side View

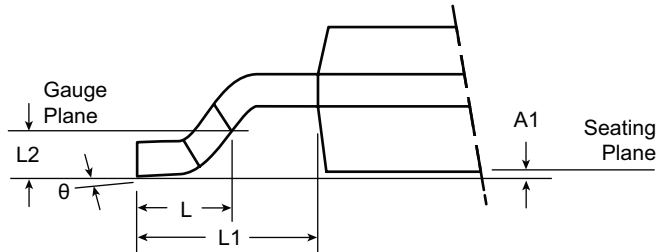

View B

Note:

1. Although 4 terminal locations are shown, only 3 are functional. Lead number 2 was removed.

Symbol	A	A1	b	b2	b3	c2	D	D1	E	E1	e	H	L	L1	L2	L3	L4	L5	θ	θ1		
Dimension (inches)	MIN	.086	.000*	.025	.030	.195	.018	.235	.205	.250	.170	.370	.055	.108 REF	.020 BSC	.035	.025*	.035†	0°	0°		
	NOM	-	-	-	-	-	-	.240	-	-	-	-	.060			-	-	-	-	-	-	-
	MAX	.094	.005	.035	.045	.215	.035	.245	.217*	.265	.200*	.410	.070			.050	.040	.060	10°	15°		

JEDEC Registration TO-252, Variation AA, Issue E, June 2004.

* This dimension is not specified in the JEDEC drawing.

† This dimension differs from the JEDEC drawing.

Drawings not to scale.

Supertex Doc. #: DSPD-3TO252K4, Version F040910.

3-Lead TO-92 Package Outline (N3)

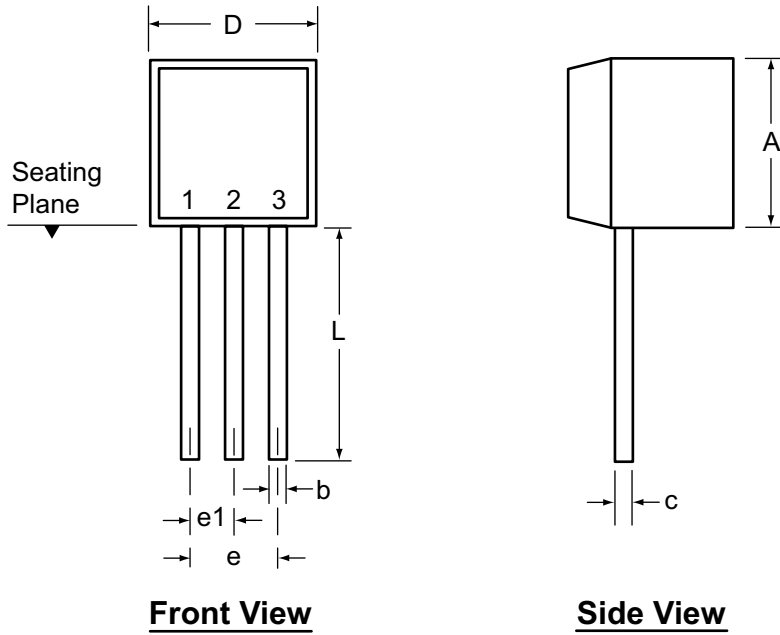

Symbol	A	b	c	D	E	E1	e	e1	L
Dimensions (inches)	MIN	.170	.014†	.175	.125	.080	.095	.045	.500
	NOM	-	-	-	-	-	-	-	-
	MAX	.210	.022†	.022†	.205	.165	.105	.105	.610*

JEDEC Registration TO-92.

* This dimension is not specified in the JEDEC drawing.

† This dimension differs from the JEDEC drawing.

Drawings not to scale.

Supertex Doc.#: DSPD-3TO92N3, Version E041009.

3-Lead TO-243AA (SOT-89) Package Outline (N8)

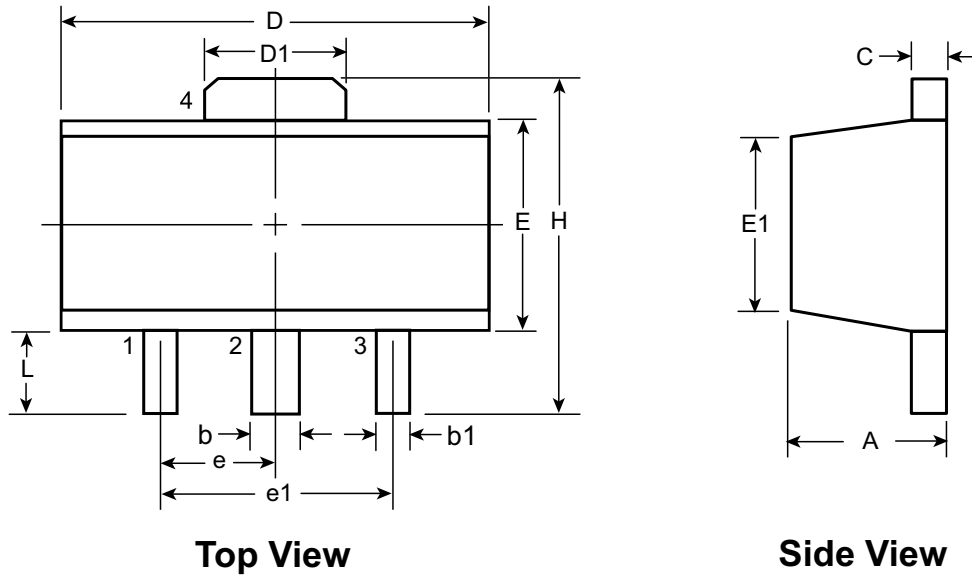

Symbol	A	b	b1	C	D	D1	E	E1	e	e1	H	L		
Dimensions (mm)	MIN	1.40	0.44	0.36	0.35	4.40	1.62	2.29	2.00 [†]	1.50 BSC	3.00 BSC	3.94	0.73 [†]	
	NOM	-	-	-	-	-	-	-	-			-	-	-
	MAX	1.60	0.56	0.48	0.44	4.60	1.83	2.60	2.29			4.25	1.20	

JEDEC Registration TO-243, Variation AA, Issue C, July 1986.

[†] This dimension differs from the JEDEC drawing

Drawings not to scale.

Supertex Doc. #: DSPD-3TO243AAN8, Version F111010.

(The package drawing(s) in this data sheet may not reflect the most current specifications. For the latest package outline information go to <http://www.supertex.com/packaging.html>.)

Supertex inc. does not recommend the use of its products in life support applications, and will not knowingly sell them for use in such applications unless it receives an adequate "product liability indemnification insurance agreement." **Supertex inc.** does not assume responsibility for use of devices described, and limits its liability to the replacement of the devices determined defective due to workmanship. No responsibility is assumed for possible omissions and inaccuracies. Circuitry and specifications are subject to change without notice. For the latest product specifications refer to the **Supertex inc.** (website: <http://www.supertex.com>)