



HESTORE.HU

elektronikai alkatrész áruház

EN: This Datasheet is presented by the manufacturer.

Please visit our website for pricing and availability at www.hestore.hu.

Preliminary datasheet RX-AUDIO-2.4

Features

1. Non-compression for high sound quality with delay time 0.5 ms.
2. Digital audio with 44.1 KHz sampling rate and 16-bit resolution.
3. FSK digital demodulation
4. Embedded antenna for cost-effect and fast development
5. Improved performance in harsh environment by antenna diversity
6. 8 selectable channels
7. Low power consumption for mobile application

Specification

Model	RX-AUDIO-2.4
Supply voltage	5±0.1 Vdc
Current consumption	65 mA (typ)
Operating temperature	-10 ÷ +60 C
Frequency range	2400 ÷ 2483.5 MHz
Modulation	FSK
Channel number	8
Channel spacing	9 MHz
Frequency stability	± 100 KHz
Sensitivity	-85 dBm (typ)
Output impedance	< 1 Kohm
Output level	3.4 Vpp (max)
Response	20 Hz ÷ 20 KHz
Dynamic range	92 dB (typ)
Separation	80 dB (typ)
SN ratio	87 dB (typ)

Board dimension

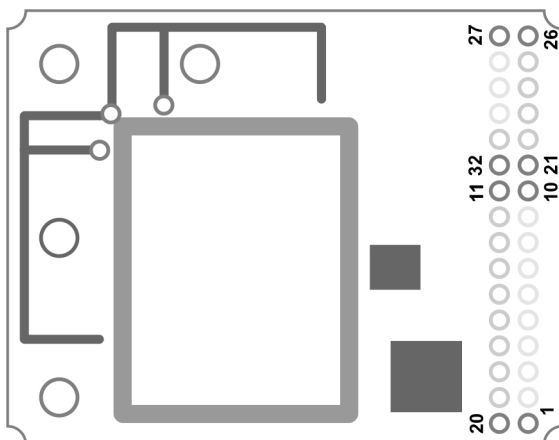

Le caratteristiche tecniche possono subire variazioni senza preavviso. La AUREL S.p.A non si assume la responsabilità di danni causati dall'uso improprio del dispositivo.
 Technical features are subject to change without notice. AUREL S.p.A. does not assume responsibilities for any damages caused by the device's misuse.

Pin configuration

Pin #	Pin name	Pin description
1	PWR_ON	The level will be logical high (2.7V) with 1-2 seconds delay after DC power supply is supplied to the module. It can then be used to turn on the audio power amplifier to prevent pop-noise when turn on RX module
2	MUTE	The level will be logical low during poor receiving condition. A few functions can be presented with simple circuits, such as receiving indicator, extra noise reduction when TX is turn off, etc...
3	USER_BIT	The data stream output, which is correspondent to the data stream applied to USER_BIT of TX module (Max data rate is 5Kbps).
4	FORMAT	Pull up for scrambling with "01" pattern. Pull down for scrambling with random pattern (internal pull high)
5	OB	Pull down to enable out-band channel for testing purpose (internal pull high)
6	TACT_SW	Impulse low to scan channel for TACT mode (internal pull high) (see table for channel setting mode)
7	VCC.	5Vdc input
8	DAC_L	L channel of audio output from DAC directly. A DC blocking capacitor (>10 uF) should be added, unless the load is high-impedance than 10KR
9	GND	Ground
10	DAC_R	R channel of audio output from DAC directly. A DC blocking capacitor (>10 uF) should be added, unless the load is high-impedance than 10KR
11	SW2	Pull low for DIP mode channel selection (internal pull high)
12	SW1	
13	SW0	
14	ID3	
15	ID2	
16	ID1	Pull low for ID selection (internal pull high)
17	ID0	
18	CH_MODE	See channel mode setting table for detail. Pull high for TACT mode and low for DIP mode (internal pull high)
19	TACT_SCAN	See channel mode setting table for detail. Pull high to enable scanning to next proper channel (internal pull high)
20	CTINU	See channel mode setting table for detail. Pull high to enable automatically channel-scan poor receiving condition (internal pull high)
21	GND	Ground
22	DC_IN	Ground
23	GND	
24	CH_R	R-channel of audio out from headphone driver directly. A DC blocking capacitor (>100 uF) should be added.
25	GND	Ground
26	CH_L	L-channel of audio out from headphone driver directly. A DC blocking capacitor (>100 uF) should be added.
27	DAC_L	Same as pin 8.
28	DAC_R	Same as pin 10.
29	AMP_R	Headphone driver R-channel input
30	AMP_L	Headphone driver L-channel input
31	GND	Ground.
32	TACT_SW	Same as pin 6.

Le caratteristiche tecniche possono subire variazioni senza preavviso. La AUREL S.p.A non si assume la responsabilità di danni causati dall'uso improprio del dispositivo.
 Technical features are subject to change without notice. AUREL S.p.A. does not assume responsibilities for any damages caused by the device's misuse.

Channel mode setting table

Channel mode	CH_MODE (pin 18)	TACT_SCAN (pin 19)	CTINU (pin 20)	Function
DIP	GND	X	X	Set SW0, SW1, and SW2 to change channel.
TACT	X	GND	X	Switch channel by channel when each low-impulse is applied to TACT_SW (pin 6)
TACT SCAN	X	X	GND	Automatically search channel when low-impulse is applied to TACT_SW (pin 6)
AUTO SCAN	X	X	X	Automatically search channel when poor receiving condition.

X means floating

Application Circuit

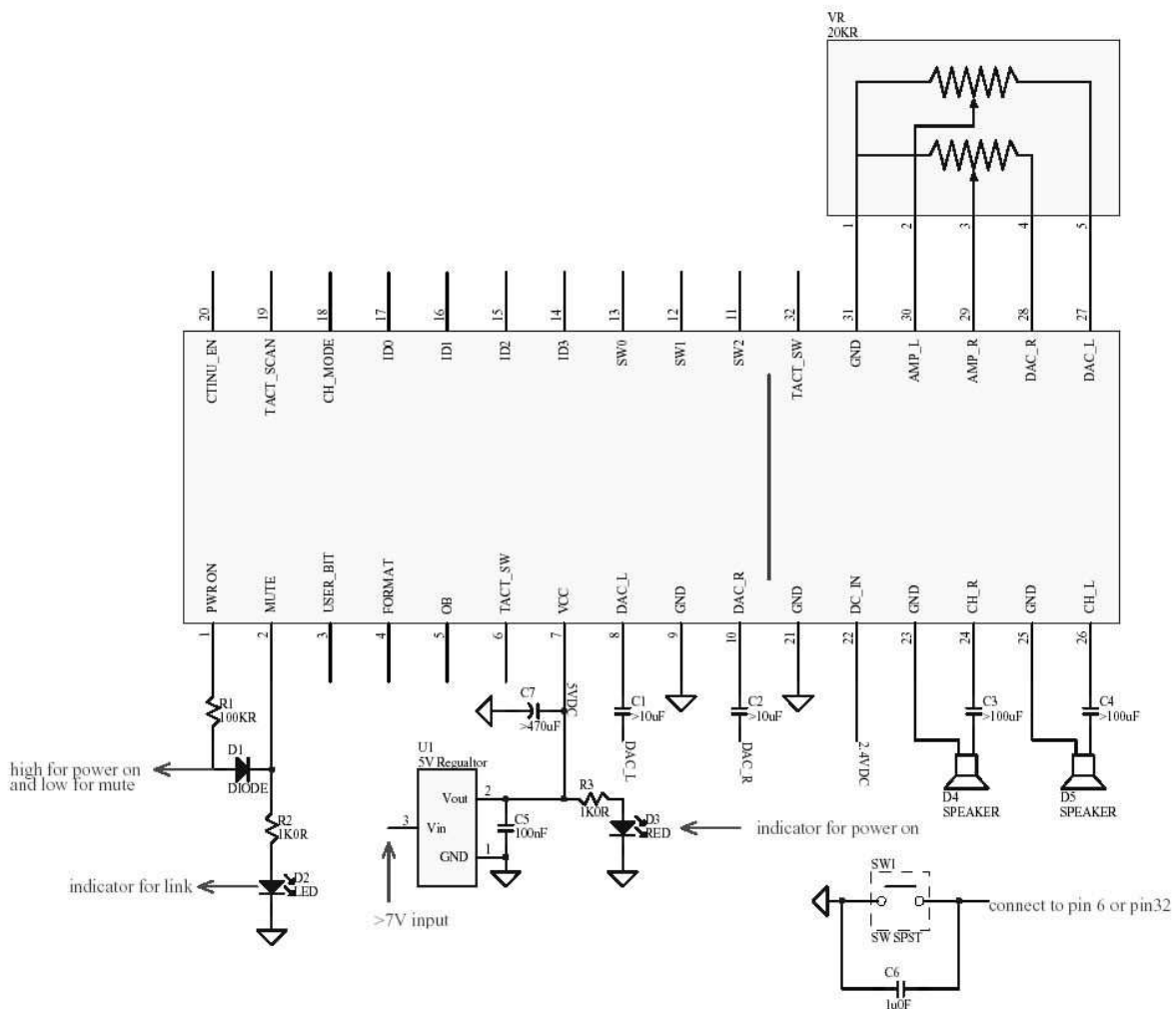

Le caratteristiche tecniche possono subire variazioni senza preavviso. La AUREL S.p.A non si assume la responsabilità di danni causati dall'uso improprio del dispositivo. Technical features are subject to change without notice. AUREL S.p.A. does not assume responsibilities for any damages caused by the device's misuse.

Application information

When you design the transmitter module in wireless speakers and headphones, pay attention to the following considerations:

1. Do not let any metal objects too close to antenna.
2. Transmitter module must be kept away from speaker over 3 cm to avoid magnetic interference.
3. Power supply to receiver module must be independent, different from the power of amplifier.
4. Avoid to put any cable or circuit nearby antenna (1-2 cm).

Antenna area marked by diagonal lines

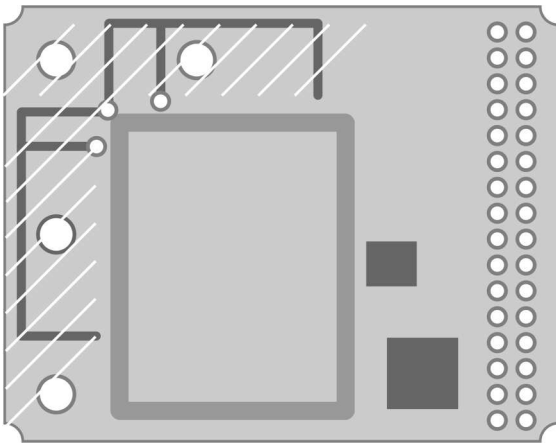

Mod. RX-AUDIO-2.4