



**HESTORE.HU**

elektronikai alkatrész áruház

**EN:** This Datasheet is presented by the manufacturer.

Please visit our website for pricing and availability at [www.hestore.hu](http://www.hestore.hu).



DIGITAL CONTROLLED STEREO AUDIO PROCESSOR

- INPUT MULTIPLEXER:
  - 4 STEREO INPUTS
  - SELECTABLE INPUT GAIN FOR OPTIMAL ADAPTION TO DIFFERENT SOURCES
- INPUT AND OUTPUT FOR EXTERNAL EQUALIZER OR NOISE REDUCTION SYSTEM
- VOLUME CONTROL IN 1.25dB STEPS
- TREBLE AND BASS CONTROL
- FOUR SPEAKER ATTENUATORS:
  - 4 INDEPENDENT SPEAKERS CONTROL IN 1.25dB STEPS FOR BALANCE AND FADER FACILITIES
  - INDEPENDENT MUTE FUNCTION
- ALL FUNCTIONS PROGRAMMABLE VIA SERIAL I<sup>2</sup>C BUS



DESCRIPTION

The TDA7318 is a volume, tone (bass and treble) balance (Left/Right) and fader (front/rear) processor for quality audio applications in car radio and Hi-Fi systems.

Selectable input gain is provided. Control is accomplished by serial I<sup>2</sup>C bus microprocessor interface. The AC signal setting is obtained by resistor networks and switches combined with operational amplifiers.

Thanks to the used BIPOLAR/CMOS Technology, Low Distortion, Low Noise and Low DC stepping are obtained.

PIN CONNECTION (Top view)

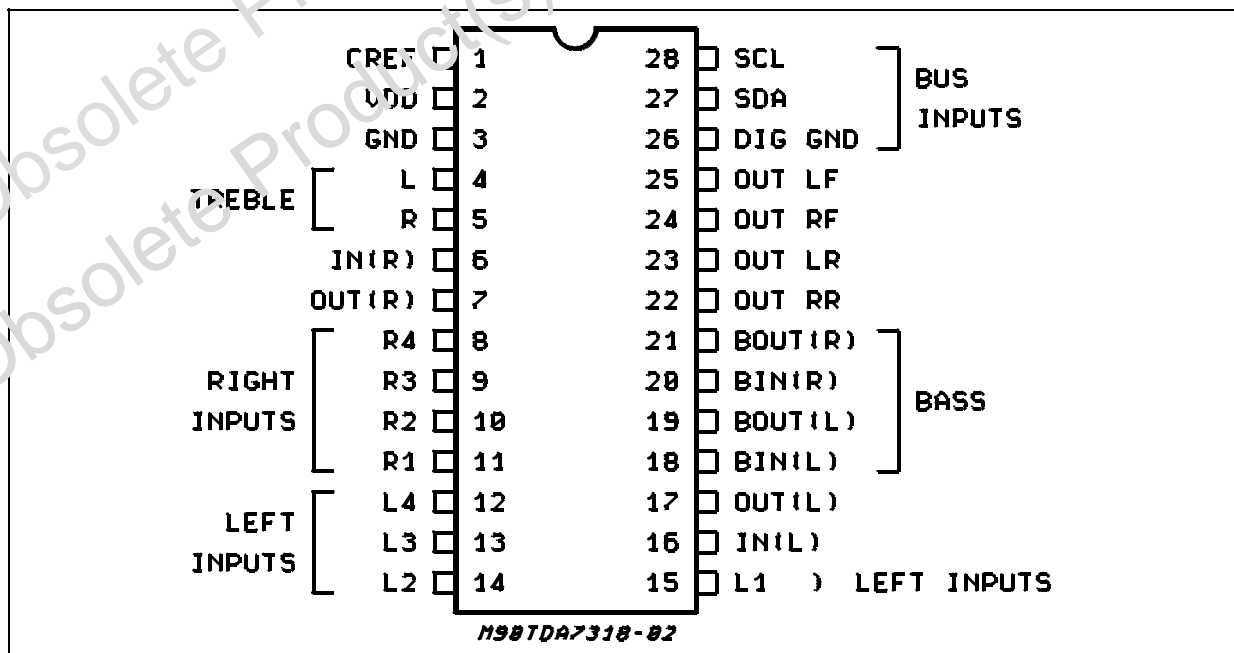

# TDA7318

## TEST CIRCUIT

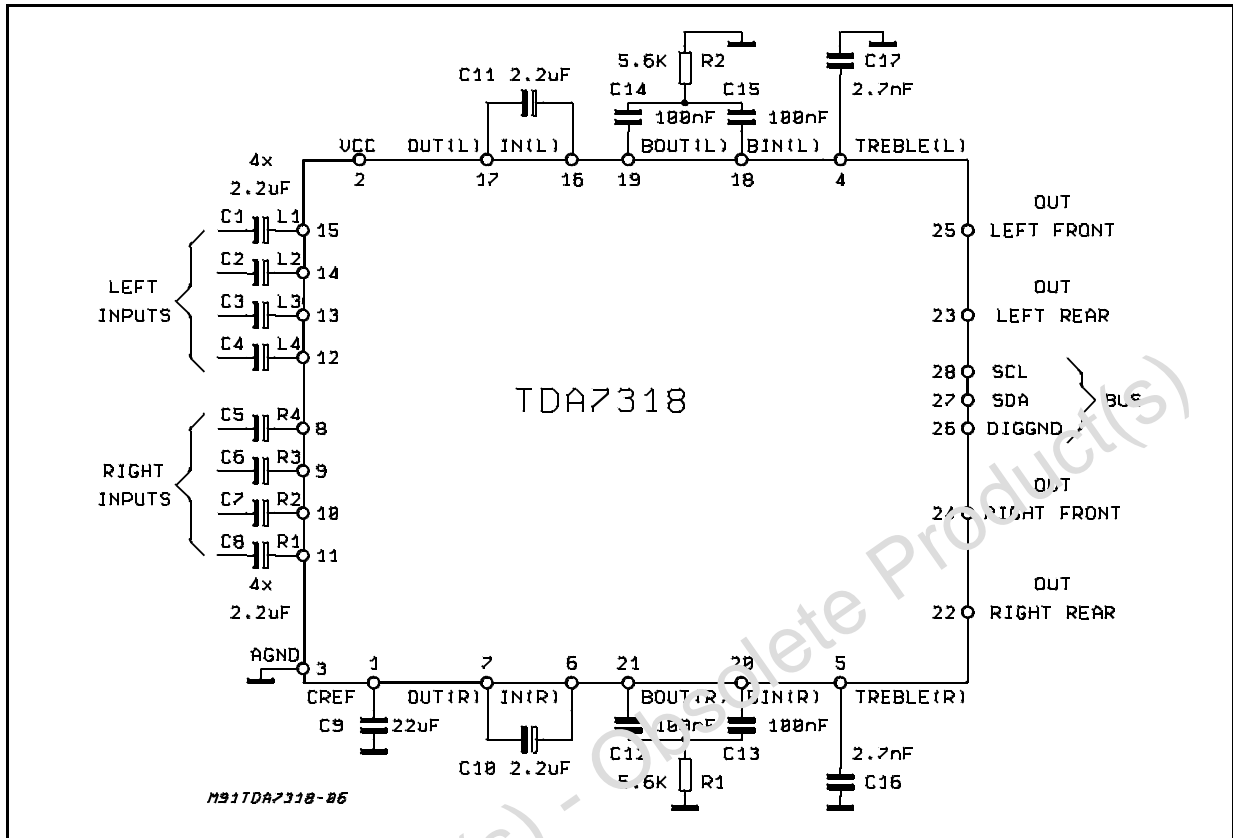

## THERMAL DATA

| Symbol           | Description                      | SO28   | DIP28 | Unit |
|------------------|----------------------------------|--------|-------|------|
| $R_{th(j-pins)}$ | Thermal Resistance Junction-pins | max 85 | 65    | °C/W |

## ABSOLUTE MAXIMUM RATINGS

| Symbol    | Parameter                     | Value       | Unit |
|-----------|-------------------------------|-------------|------|
| $V_S$     | Operating Supply Voltage      | 10.2        | V    |
| $T_{amb}$ | Operating Ambient Temperature | -40 to 85   | °C   |
| $T_{stg}$ | Storage Temperature Range     | -55 to +150 | °C   |

## QUICK REFERENCE DATA

| Symbol   | Parameter   | Min.   | Typ. | Max.  | Unit             |
|----------|---|--------|------|-------|------------------|
| $V_S$    | Supply Voltage                                      | 6      | 9    | 10    | V                |
| $V_{CL}$ | Max. input signal handling                          | 2      |      |       | V <sub>rms</sub> |
| THD      | Total Harmonic Distortion $V = 1V_{rms}$ $f = 1KHz$ |        | 0.01 | 0.1   | %                |
| S/N      | Signal to Noise Ratio                               |        | 106  |       | dB               |
| $S_C$    | Channel Separation $f = 1KHz$                       |        | 103  |       | dB               |
|          | Volume Control 1.25dB step                          | -78.75 |      | 0     | dB               |
|          | Bass and Treble Control 2db step                    | -14    |      | +14   | dB               |
|          | Fader and Balance Control 1.25dB step               | -38.75 |      | 0     | dB               |
|          | Input Gain 6.25dB step                              | 0      |      | 18.75 | dB               |
|          | Mute Attenuation                                    |        | 100  |       | dB               |

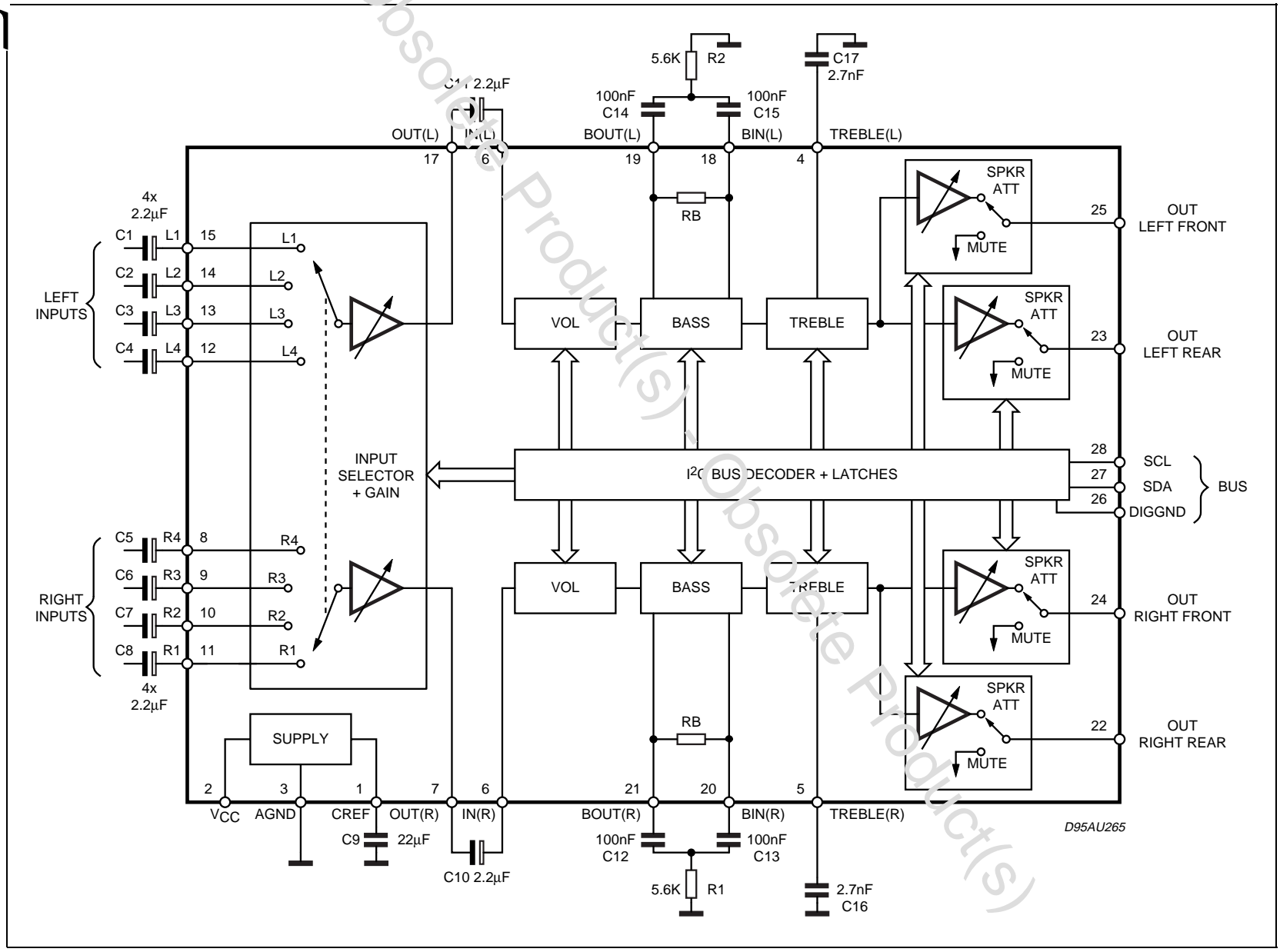

BLOCK DIAGRAM

## TDA7318

**ELECTRICAL CHARACTERISTICS** (refer to the test circuit  $T_{amb} = 25^{\circ}\text{C}$ ,  $V_S = 9\text{V}$ ,  $R_L = 10\text{K}\Omega$ ,  $R_G = 600\Omega$ , all controls flat ( $G = 0$ ),  $f = 1\text{KHz}$  unless otherwise specified)

| Symbol | Parameter | Test Condition | Min. | Typ. | Max. | Unit |
|--------|-----------|----------------|------|------|------|------|
|--------|-----------|----------------|------|------|------|------|

### SUPPLY

|       |                  |  |    |    |    |    |
|-------|------------------|--|----|----|----|----|
| $V_S$ | Supply Voltage   |  | 6  | 9  | 10 | V  |
| $I_S$ | Supply Current   |  | 4  | 8  | 11 | mA |
| SVR   | Ripple Rejection |  | 60 | 85 |    | dB |

### INPUT SELECTORS

|             |                        |                      |    |       |     |                  |
|-------------|------------------------|----------------------|----|-------|-----|------------------|
| $R_{II}$    | Input Resistance       | Input 1, 2, 3, 4     | 35 | 50    | 70  | $\text{K}\Omega$ |
| $V_{CL}$    | Clipping Level         |                      | 2  | 2.5   |     | $V_{rms}$        |
| $S_{IN}$    | Input Separation (2)   |                      | 80 | 100   |     | dB               |
| $R_L$       | Output Load resistance | pin 7, 17            | 2  |       |     | $\text{K}\Omega$ |
| $G_{INmin}$ | Min. Input Gain        |                      | -1 | 0     | 1   | dB               |
| $G_{INmax}$ | Max. Input Gain        |                      | 17 | 15.75 | 20  | dB               |
| $G_{STEP}$  | Step Resolution        |                      | 5  | 3.25  | 7.5 | dB               |
| $e_{IN}$    | Input Noise            | $G = 18.75\text{dB}$ |    | 2     |     | $\mu\text{V}$    |
| $V_{DC}$    | DC Steps               | adjacent gain steps  |    | 4     | 20  | mV               |
|             |                        | $G = 18.75$ to Mute  |    | 4     |     | mV               |

### VOLUME CONTROL

|             |                       |   |       |      |      |                  |
|-------------|-----------------------|---|-------|------|------|------------------|
| $R_{IV}$    | Input Resistance      |   | 20    | 33   | 50   | $\text{k}\Omega$ |
| $C_{RANGE}$ | Control Range         |   | 70    | 75   | 80   | dB               |
| $A_{VMIN}$  | Min. Attenuation      |   | -1    | 0    | 1    | dB               |
| $A_{VMAX}$  | Max. Attenuation      |   | 70    | 75   | 80   | dB               |
| $A_{STEP}$  | Step Resolution       |   | 0.5   | 1.25 | 1.75 | dB               |
| $E_A$       | Attenuation Set Error | $A_v = 0$ to $-20\text{dB}$                         | -1.25 | 0    | 1.25 | dB               |
|             |                       | $A_v = -20$ to $-60\text{dB}$                       | -3    |      | 2    | dB               |
| $E_T$       | Tracking Error        |   |       |      | 2    | dB               |
| $V_{DC}$    | DC Steps              | adjacent attenuation steps<br>From 0dB to $A_v$ max |       | 0    | 3    | mV               |
|             |                       |   |       | 0.5  | 7.5  | mV               |

### SPEAKER ATTENUATORS

|             |                         |                                       |     |      |      |    |
|-------------|-------------------------|---------------------------------------|-----|------|------|----|
| $C_{RANGE}$ | Control Range           |                                       | 35  | 37.5 | 40   | dB |
| $A_{STEP}$  | Step Resolution         |                                       | 0.5 | 1.25 | 1.75 | dB |
| $E_A$       | Attenuation set error   |                                       |     |      | 1.5  | dB |
| $A_{MUTE}$  | Output Mute Attenuation |                                       | 80  | 100  |      | dB |
| $V_{DC}$    | DC Steps                | adjacent att. steps<br>from 0 to mute |     | 0    | 3    | mV |
|             |                         |                                       |     | 1    | 10   | mV |

### BASS CONTROL (1)

|            |                              |                |          |          |          |                  |
|------------|------------------------------|----------------|----------|----------|----------|------------------|
| $G_b$      | Control Range                | Max. Boost/cut | $\pm 12$ | $\pm 14$ | $\pm 16$ | dB               |
| $B_{STEP}$ | Step Resolution              |                | 1        | 2        | 3        | dB               |
| $R_B$      | Internal Feedback Resistance |                | 34       | 44       | 58       | $\text{K}\Omega$ |

### TREBLE CONTROL (1)

|            |                 |                |          |          |          |    |
|------------|-----------------|----------------|----------|----------|----------|----|
| $G_t$      | Control Range   | Max. Boost/cut | $\pm 13$ | $\pm 14$ | $\pm 15$ | dB |
| $T_{STEP}$ | Step Resolution |                | 1        | 2        | 3        | dB |

**ELECTRICAL CHARACTERISTICS** (continued)

| Symbol               | Parameter               | Test Condition | Min. | Typ. | Max. | Unit             |
|----------------------|-------------------------|----------------|------|------|------|------------------|
| <b>AUDIO OUTPUTS</b> |                         |                |      |      |      |                  |
| V <sub>OCL</sub>     | Clipping Level          | d = 0.3%       | 2    | 2.5  |      | V <sub>rms</sub> |
| R <sub>L</sub>       | Output Load Resistance  |                | 2    |      |      | KΩ               |
| C <sub>L</sub>       | Output Load Capacitance |                |      |      | 10   | nF               |
| R <sub>OUT</sub>     | Output resistance       |                | 30   | 75   | 120  | Ω                |
| V <sub>OUT</sub>     | DC Voltage Level        |                | 4.2  | 4.5  | 4.8  | V                |

**GENERAL**

|                 |                               |  |    |                      |            |             |
|-----------------|-------------------------------|--|----|----------------------|------------|-------------|
| e <sub>NO</sub> | Output Noise                  | BW = 20-20KHz, flat output muted all gains = 0dB   |    | 2.5<br>5             | 15         | μV<br>μV    |
|                 |                               | A curve all gains = 0dB  |    | 3                    |            | μV          |
| S/N             | Signal to Noise Ratio         | all gains = 0dB; V <sub>O</sub> = 1V <sub>rms</sub>  |    | 106                  |            | dB          |
| d               | Distortion                    | A <sub>V</sub> = 0, V <sub>IN</sub> = 1V <sub>rms</sub><br>A <sub>V</sub> = -20dB V <sub>IN</sub> = 1V <sub>rms</sub><br>V <sub>IN</sub> = 0.3V <sub>rms</sub> |    | 0.01<br>0.09<br>0.04 | 0.1<br>0.3 | %<br>%<br>% |
| Sc              | Channel Separation left/right |  | 80 | 103                  |            | dB          |
|                 | Total Tracking error          | A <sub>V</sub> = 0 to -20dB<br>-20 to -60 dB   |    | 0<br>0               | 1<br>2     | dB<br>dB    |

**BUS INPUTS**

|                 |                                |                        |    |  |     |    |
|-----------------|--------------------------------|------------------------|----|--|-----|----|
| V <sub>IL</sub> | Input Low Voltage              |                        |    |  | 1   | V  |
| V <sub>IH</sub> | Input High Voltage             |                        | 3  |  |     | V  |
| I <sub>IN</sub> | Input Current                  |                        | -5 |  | +5  | μA |
| V <sub>O</sub>  | Output Voltage SDA Acknowledge | I <sub>O</sub> = 1.6mA |    |  | 0.4 | V  |

**Notes:**

- (1) Bass and Treble response see attached diagram (fig.19). The center frequency and quality of the resonance behaviour can be chosen by the external circuitry. A standard first order bass response can be realized by a standard feedback network
- (2) The selected input is grounded thru the 2.2μF capacitor.

**Figure 1: Noise vs. Volume/Gain Settings**

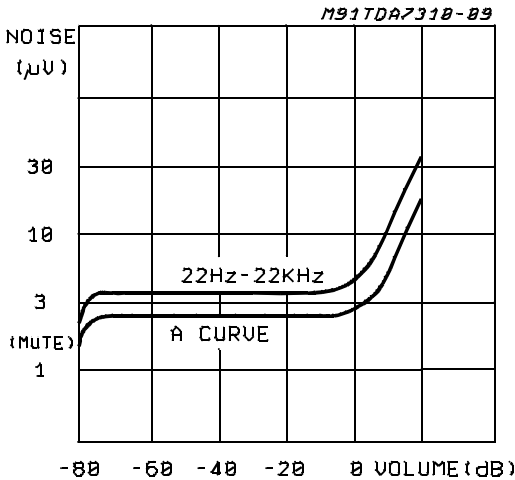

**Figure 2: Signal to Noise Ratio vs. Volume Setting**

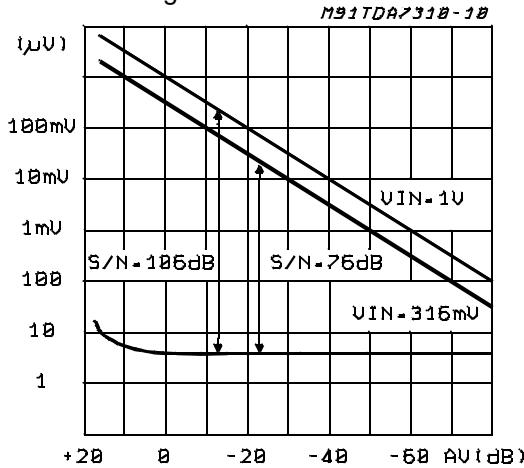

Figure 3: Distortion & Noise vs. Frequency

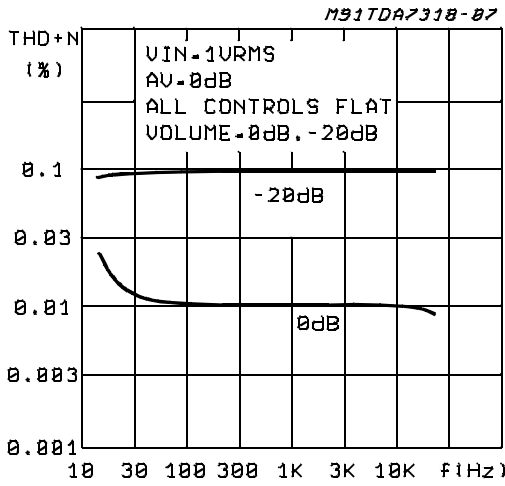

Figure 4: Distortion & Noise vs. Frequency

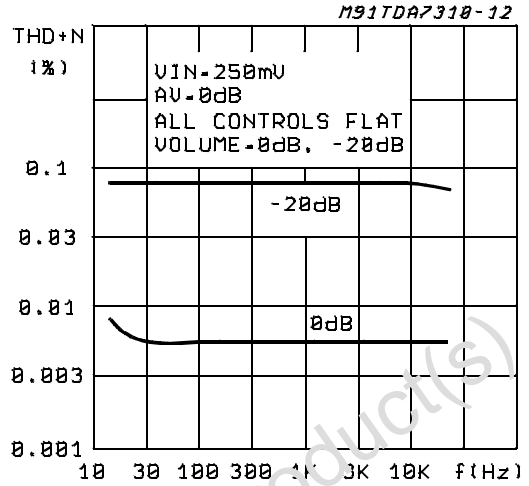

Figure 5: Distortion vs. Load Resistance

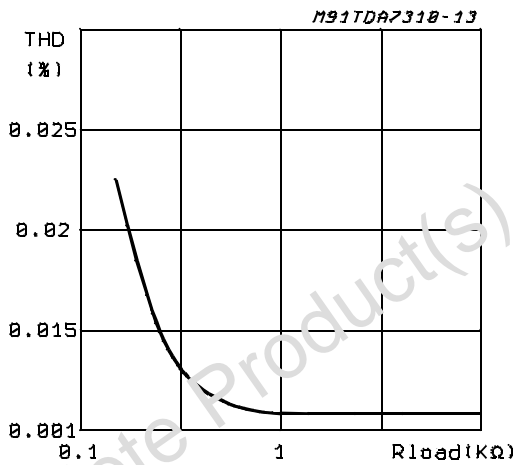

Figure 6: Channel Separation (L → R) vs. Frequency

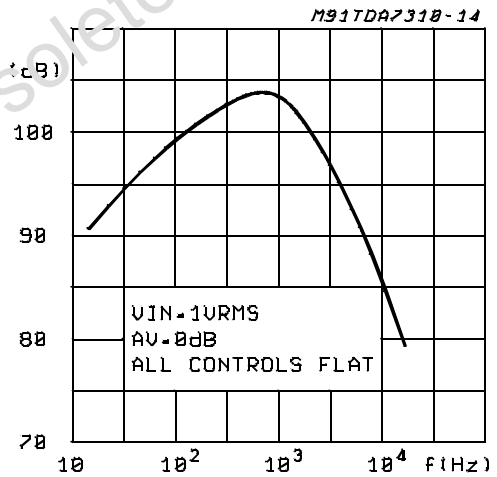

Figure 7: Input Separation (L1 → L2, L3, L4) vs. Frequency

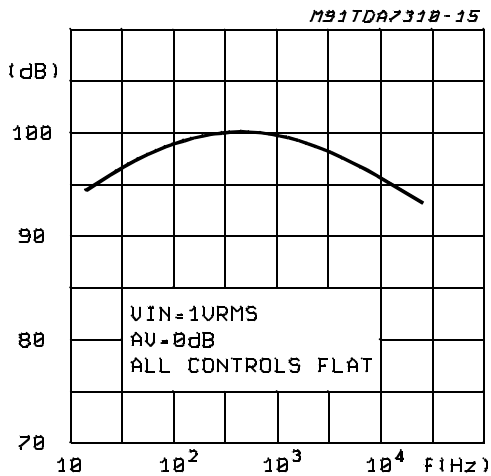
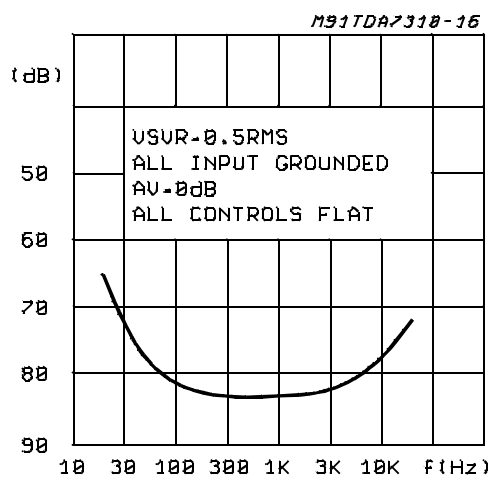
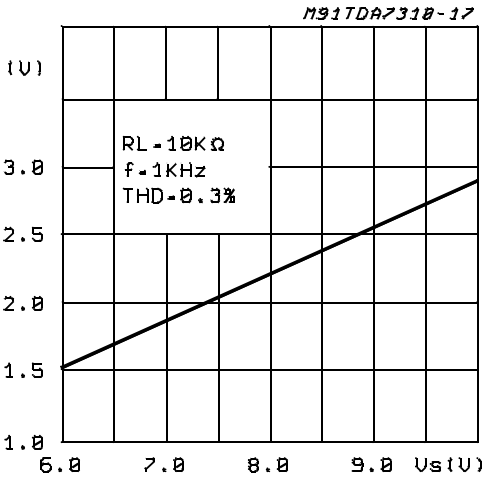

Figure 8: Supply Voltage Rejection vs. Frequency



**Figure 9:** Output Clipping Level vs. Supply Voltage



**Figure 10:** Quiescent Current vs. Supply Voltage

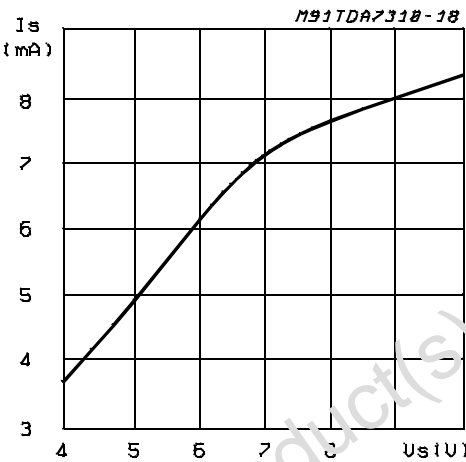

**Figure 11:** Supply Current vs. Temperature

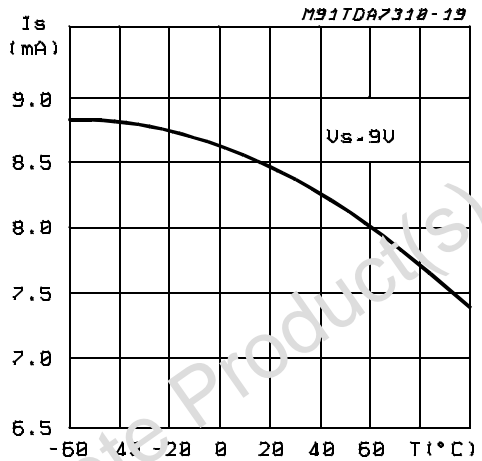

**Figure 12:** Bass Resistance vs. Temperature

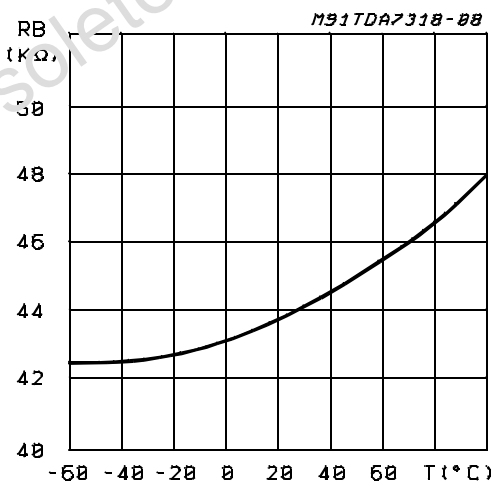

**Figure 13:** Typical Tone Response (with the ext. components indicated in the test circuit)

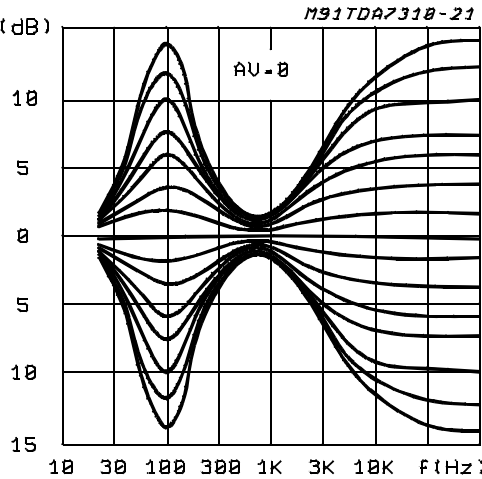



**I<sup>2</sup>C BUS INTERFACE**

Data transmission from microprocessor to the TDA7318 and viceversa takes place thru the 2 wires I<sup>2</sup>C BUS interface, consisting of the two lines SDA and SCL (pull-up resistors to positive supply voltage must be connected).

**Data Validity**

As shown in fig. 14, the data on the SDA line must be stable during the high period of the clock. The HIGH and LOW state of the data line can only change when the clock signal on the SCL line is LOW.

**Start and Stop Conditions**

As shown in fig.15 a start condition is a HIGH to LOW transition of the SDA line while SCL is HIGH. The stop condition is a LOW to HIGH transition of the SDA line while SCL is HIGH.

**Byte Format**

Every byte transferred on the SDA line must contain 8 bits. Each byte must be followed by an ac-

knowledge bit. The MSB is transferred first.

**Acknowledge**

The master ( $\mu$ P) puts a resistive HIGH level on the SDA line during the acknowledge clock pulse (see fig. 16). The peripheral (audioprocessor) that acknowledges has to pull-down (LOW) the SDA line during the acknowledge clock pulse, so that the SDA line is stable LOW during this clock pulse.

The audioprocessor which has been addressed has to generate an acknowledge after the reception of each byte, otherwise the SDA line remains at the HIGH level during the ninth clock pulse time. In this case the master transmitter can generate the STOP information in order to abort the transfer.

**Transmission without Acknowledge**

Avoiding to detect the acknowledge of the audioprocessor, the  $\mu$ P can use a simpler transmission: simply it waits one clock without checking the slave acknowledging, and sends the new data.

This approach, of course is less protected from misworking and decreases the noise immunity.

**Figure 14:** Data Validity on the I<sup>2</sup>C BUS

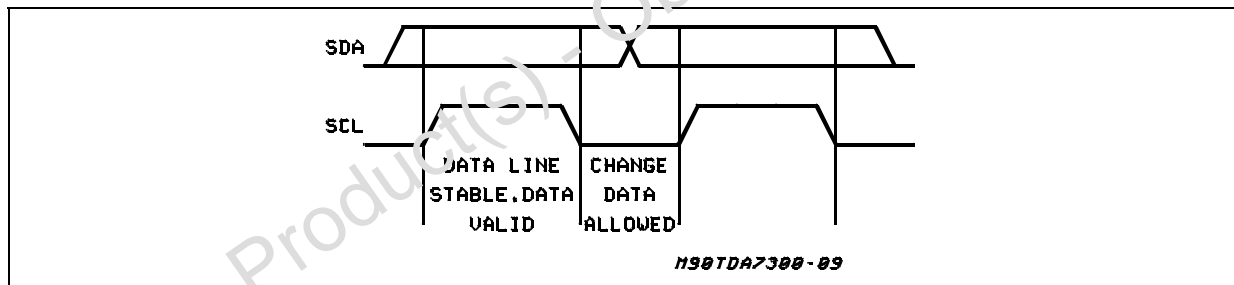

**Figure 15:** Timing Diagram of I<sup>2</sup>C BUS

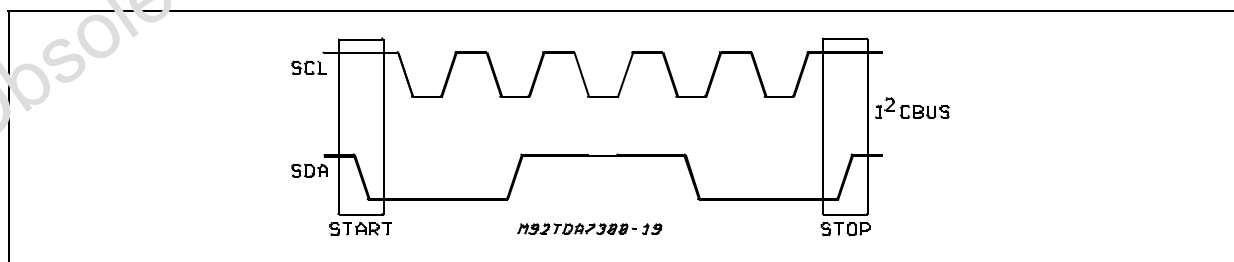

**Figure 16:** Acknowledge on the I<sup>2</sup>C BUS

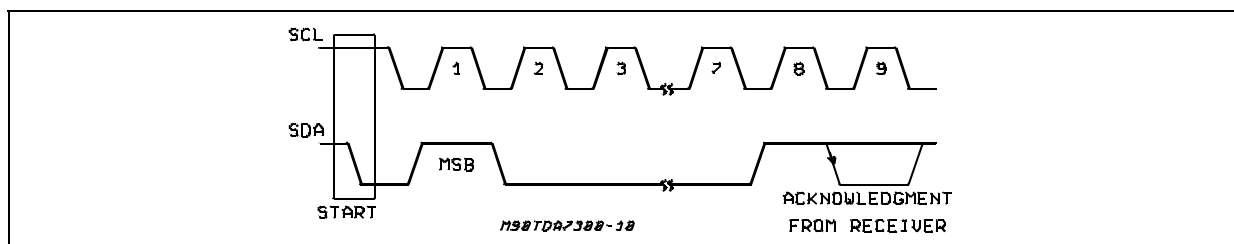

**SOFTWARE SPECIFICATION**

**Interface Protocol**

The interface protocol comprises:

- A start condition (s)
- A chip address byte, containing the TDA7318

address (the 8th bit of the byte must be 0). The TDA7318 must always acknowledge at the end of each transmitted byte.

- A sequence of data (N-bytes + acknowledge)
- A stop condition (P)

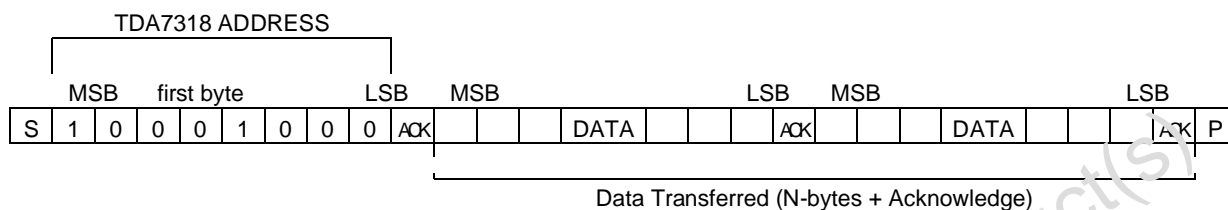

ACK = Acknowledge  
 S = Start  
 P = Stop

MAX CLOCK SPEED 100kbts/s

**SOFTWARE SPECIFICATION**

Chip address

|     |   |   |   |   |   |   |     |
|-----|---|---|---|---|---|---|-----|
| 1   | 0 | 0 | 0 | 1 | 0 | 0 | 0   |
| MSB |   |   |   |   |   |   | LSB |

DATA BYTES

| MS3 |   |    |    |    |    |    |    | LSB | FUNCTION       |
|-----|---|----|----|----|----|----|----|-----|----------------|
| 0   | 0 | B2 | B1 | B0 | A2 | A1 | A0 | A0  | Volume control |
| 1   | 1 | 0  | B1 | B0 | A2 | A1 | A0 | A0  | Speaker ATT LR |
| 1   | 1 | 1  | B1 | B0 | A2 | A1 | A0 | A0  | Speaker ATT RR |
| 1   | 0 | 0  | B1 | B0 | A2 | A1 | A0 | A0  | Speaker ATT LF |
| 1   | 0 | 1  | B1 | B0 | A2 | A1 | A0 | A0  | Speaker ATT RF |
| 0   | 1 | 0  | G1 | G0 | S2 | S1 | S0 | S0  | Audio switch   |
| 0   | 1 | 1  | 0  | C3 | C2 | C1 | C0 | C0  | Bass control   |
| 0   | 1 | 1  | 1  | C3 | C2 | C1 | C0 | C0  | Treble control |

Ax = 1.25dB steps; Bx = 10dB steps; Cx = 2dB steps; Gx = 6.25dB steps

## TDA7318

### SOFTWARE SPECIFICATION (continued)

#### DATA BYTES (detailed description)

#### Volume

| MSB |   |    |    | LSB |    |    | FUNCTION |                     |
|-----|---|----|----|-----|----|----|----------|---------------------|
| 0   | 0 | B2 | B1 | B0  | A2 | A1 | A0       | Volume 1.25dB steps |
|     |   |    |    |     | 0  | 0  | 0        | 0                   |
|     |   |    |    |     | 0  | 0  | 1        | -1.25               |
|     |   |    |    |     | 0  | 1  | 0        | -2.5                |
|     |   |    |    |     | 0  | 1  | 1        | -3.75               |
|     |   |    |    |     | 1  | 0  | 0        | -5                  |
|     |   |    |    |     | 1  | 0  | 1        | -6.25               |
|     |   |    |    |     | 1  | 1  | 0        | -7.5                |
|     |   |    |    |     | 1  | 1  | 1        | -8.75               |
| 0   | 0 | B2 | B1 | B0  | A2 | A1 | A0       | Volume 10dB steps   |
|     |   | 0  | 0  | 0   |    |    |          | 0                   |
|     |   | 0  | 0  | 1   |    |    |          | -10                 |
|     |   | 0  | 1  | 0   |    |    |          | -20                 |
|     |   | 0  | 1  | 1   |    |    |          | -30                 |
|     |   | 1  | 0  | 0   |    |    |          | -40                 |
|     |   | 1  | 0  | 1   |    |    |          | -50                 |
|     |   | 1  | 1  | 0   |    |    |          | -60                 |
|     |   | 1  | 1  | 1   |    |    |          | -70                 |

For example a volume of -45dB is given by:

0 0 1 0 0 1 0 0

#### Speaker Attenuators

| MSB |   |   |    | LSB |    |    | FUNCTION |            |
|-----|---|---|----|-----|----|----|----------|------------|
| 1   | 0 | 0 | B1 | B0  | A2 | A1 | A0       | Speaker LF |
| 1   | 0 | 1 | B1 | B0  | A2 | A1 | A0       | Speaker RF |
| 1   | 1 | 0 | B1 | B0  | A2 | A1 | A0       | Speaker LR |
| 1   | 1 | 1 | B1 | B0  | A2 | A1 | A0       | Speaker RR |
|     |   |   |    |     | 0  | 0  | 0        | 0          |
|     |   |   |    |     | 0  | 0  | 1        | -1.25      |
|     |   |   |    |     | 0  | 1  | 0        | -2.5       |
|     |   |   |    |     | 0  | 1  | 1        | -3.75      |
|     |   |   |    |     | 1  | 0  | 0        | -5         |
|     |   |   |    |     | 1  | 0  | 1        | -6.25      |
|     |   |   |    |     | 1  | 1  | 0        | -7.5       |
|     |   |   |    |     | 1  | 1  | 1        | -8.75      |
|     |   | 0 | 0  |     |    |    |          | 0          |
|     |   | 0 | 1  |     |    |    |          | -10        |
|     |   | 1 | 0  |     |    |    |          | -20        |
|     |   | 1 | 1  |     |    |    |          | -30        |
|     |   | 1 | 1  | 1   | 1  | 1  | 1        | Mute       |

For example attenuation of 25dB on speaker RF is given by:

1 0 1 1 0 1 0 0

**Audio Switch**

| MSB |   |   |    |    |    |    | LSB | FUNCTION     |
|-----|---|---|----|----|----|----|-----|--------------|
| 0   | 1 | 0 | G1 | G0 | S2 | S1 | S0  | Audio Switch |
|     |   |   |    |    | 0  | 0  | 0   | Stereo 1     |
|     |   |   |    |    | 0  | 0  | 1   | Stereo 2     |
|     |   |   |    |    | 0  | 1  | 0   | Stereo 3     |
|     |   |   |    |    | 0  | 1  | 1   | Stereo 4     |
|     |   |   |    |    | 1  | 0  | 0   | Not allowed  |
|     |   |   |    |    | 1  | 0  | 1   | Not allowed  |
|     |   |   |    |    | 1  | 1  | 0   | Not allowed  |
|     |   |   |    |    | 1  | 1  | 1   | Not allowed  |
|     |   |   | 0  | 0  |    |    |     | +18.75dB     |
|     |   |   | 0  | 1  |    |    |     | +12.5dB      |
|     |   |   | 1  | 0  |    |    |     | +6.25dB      |
|     |   |   | 1  | 1  |    |    |     | 0dB          |

For example to select the stereo 2 input with a gain of +12.5dB the 8bit string is:

0 1 0 0 1 0 0 1

**Bass and Treble**

| 0 | 1 | 1 | 0 | C3 | C2 | C1 | C0 | Bass   |
|---|---|---|---|----|----|----|----|--------|
| 0 | 1 | 1 | 1 | C3 | C2 | C1 | C0 | Treble |
|   |   |   |   | 0  | 0  | 0  | 0  | -14    |
|   |   |   |   | 0  | 0  | 0  | 1  | -12    |
|   |   |   |   | 0  | 0  | 1  | 0  | -10    |
|   |   |   |   | 0  | 0  | 1  | 1  | -8     |
|   |   |   |   | 0  | 1  | 0  | 0  | -6     |
|   |   |   |   | 0  | 1  | 0  | 1  | -4     |
|   |   |   |   | 0  | 1  | 1  | 0  | -2     |
|   |   |   |   | 0  | 1  | 1  | 1  | 0      |
|   |   |   |   | 1  | 1  | 1  | 1  | 0      |
|   |   |   |   | 1  | 1  | 1  | 0  | 2      |
|   |   |   |   | 1  | 1  | 0  | 1  | 4      |
|   |   |   |   | 1  | 1  | 0  | 0  | 6      |
|   |   |   |   | 1  | 0  | 1  | 1  | 8      |
|   |   |   |   | 1  | 0  | 1  | 0  | 10     |
|   |   |   |   | 1  | 0  | 0  | 1  | 12     |
|   |   |   |   | 1  | 0  | 0  | 0  | 14     |

C3 = Sign

For example Bass at -10dB is obtained by the following 8 bit string:

0 1 1 0 0 0 1 0

| DIM. | mm         |       |       | inch  |       |       |
|------|------------|-------|-------|-------|-------|-------|
|      | MIN.       | TYP.  | MAX.  | MIN.  | TYP.  | MAX.  |
| A    |            |       | 2.65  |       |       | 0.104 |
| a1   | 0.1        |       | 0.3   | 0.004 |       | 0.012 |
| b    | 0.35       |       | 0.49  | 0.014 |       | 0.019 |
| b1   | 0.23       |       | 0.32  | 0.009 |       | 0.013 |
| C    |            | 0.5   |       |       | 0.020 |       |
| c1   | 45° (typ.) |       |       |       |       |       |
| D    | 17.7       |       | 18.1  | 0.697 |       | 0.713 |
| E    | 10         |       | 10.65 | 0.394 |       | 0.419 |
| e    |            | 1.27  |       |       | 0.050 |       |
| e3   |            | 16.51 |       |       | 0.65  |       |
| F    | 7.4        |       | 7.6   | 0.291 |       | 0.299 |
| L    | 0.4        |       | 1.27  | 0.016 |       | 0.050 |
| S    | 8° (max.)  |       |       |       |       |       |

### OUTLINE AND MECHANICAL DATA

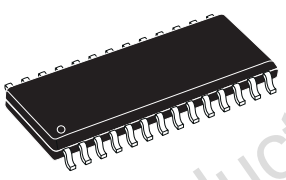

Obsolete Product(s)

## SO28

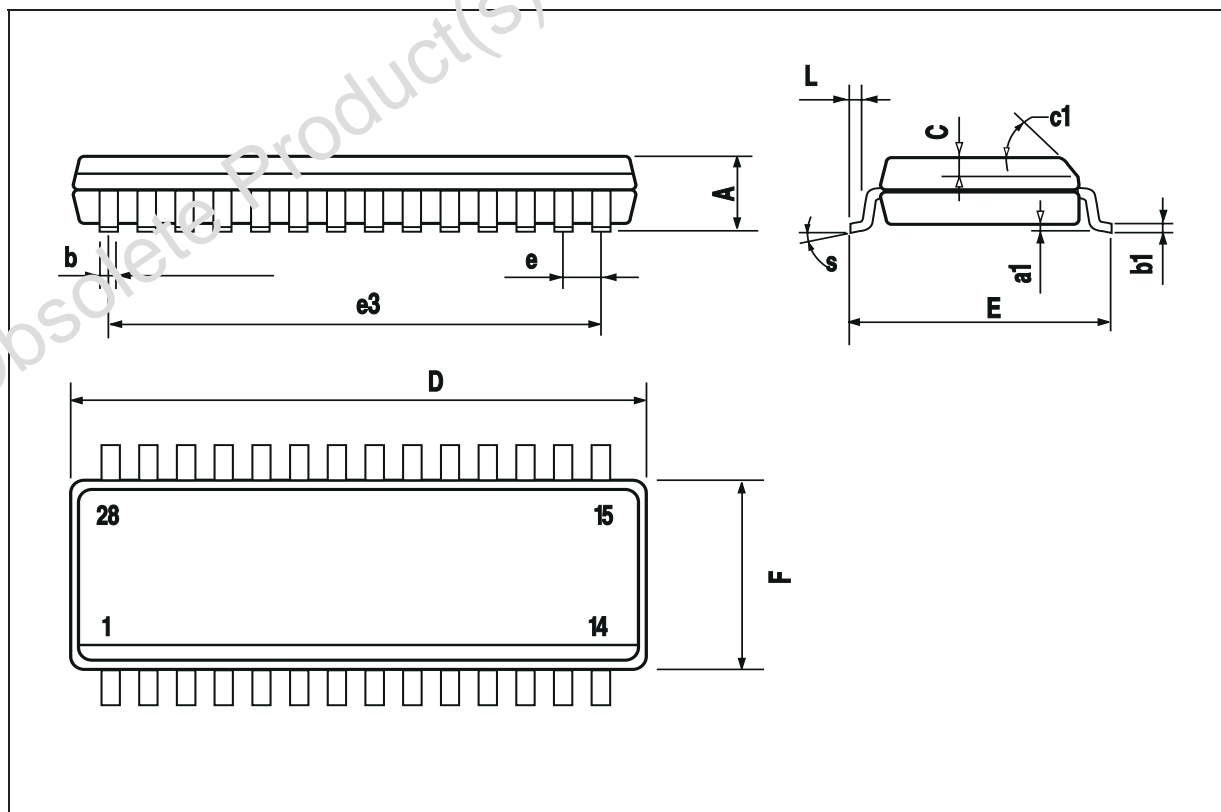

| DIM. | mm   |       |       | inch  |       |       |
|------|------|-------|-------|-------|-------|-------|
|      | MIN. | TYP.  | MAX.  | MIN.  | TYP.  | MAX.  |
| a1   |      | 0.63  |       |       | 0.025 |       |
| b    |      | 0.45  |       |       | 0.018 |       |
| b1   | 0.23 |       | 0.31  | 0.009 |       | 0.012 |
| b2   |      | 1.27  |       |       | 0.050 |       |
| D    |      |       | 37.34 |       |       | 1.470 |
| E    | 15.2 |       | 16.68 | 0.598 |       | 0.657 |
| e    |      | 2.54  |       |       | 0.100 |       |
| e3   |      | 33.02 |       |       | 1.300 |       |
| F    |      |       | 14.1  |       |       | 0.555 |
| I    |      | 4.445 |       |       | 0.175 |       |
| L    |      | 3.3   |       |       | 0.130 |       |

**OUTLINE AND MECHANICAL DATA**

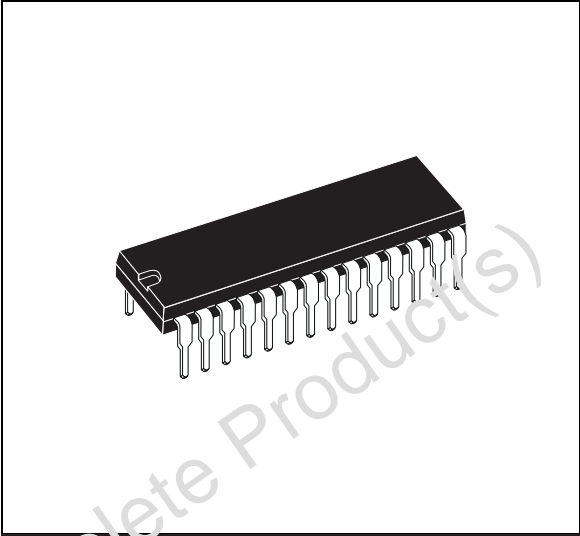

**DIP28**

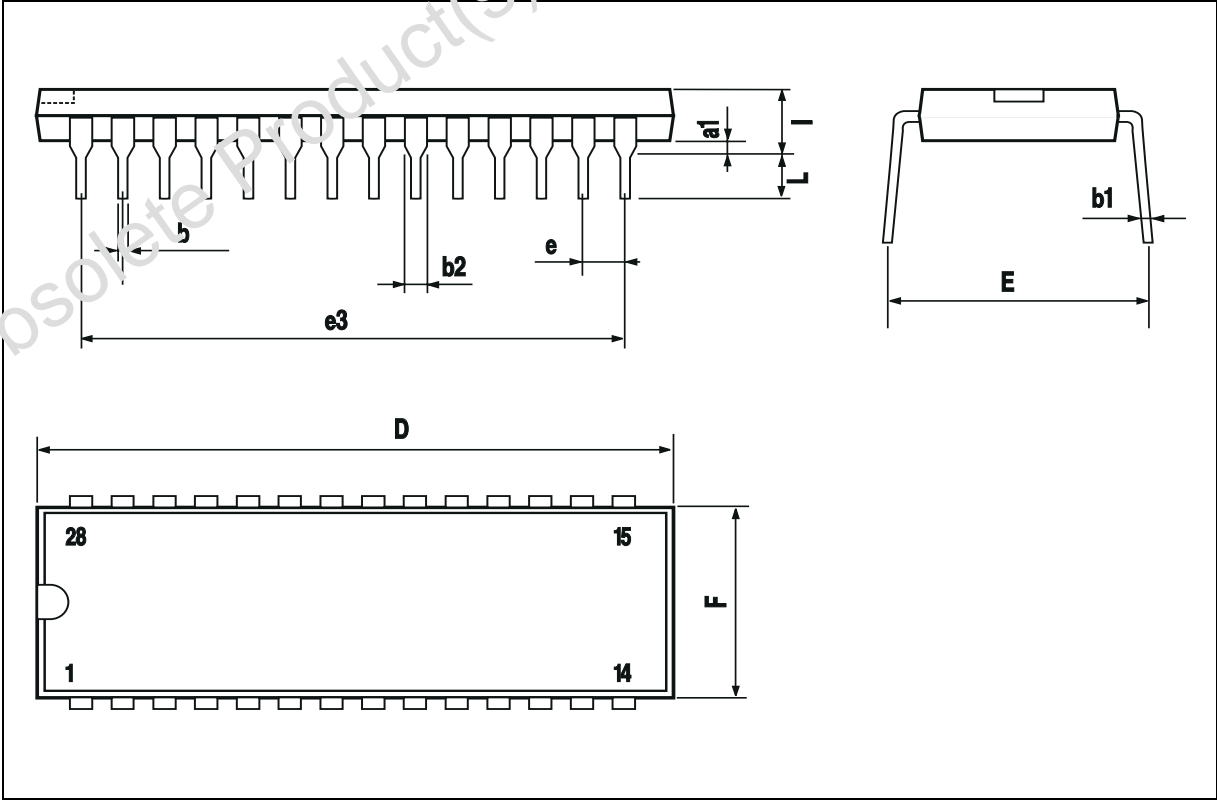

Obsolete Product(s) - Obsolete Product(s)

Information furnished is believed to be accurate and reliable. However, STMicroelectronics assumes no responsibility for the consequences of use of such information nor for any infringement of patents or other rights of third parties which may result from its use. No license is granted by implication or otherwise under any patent or patent rights of STMicroelectronics. Specification mentioned in this publication are subject to change without notice. This publication supersedes and replaces all information previously supplied. STMicroelectronics products are not authorized for use as critical components in life support devices or systems without express written approval of STMicroelectronics.

The ST logo is a registered trademark of STMicroelectronics

© 1999 STMicroelectronics – Printed in Italy – All Rights Reserved

Purchase of I<sup>2</sup>C Components of STMicroelectronics, conveys a license under the Philips I<sup>2</sup>C Patent Rights to use these components in an I<sup>2</sup>C system, provided that the system conforms to the I<sup>2</sup>C Standard Specifications as defined by Philips.

STMicroelectronics GROUP OF COMPANIES

Australia - Brazil - China - Finland - France - Germany - Hong Kong - India - Italy - Japan - Malaysia - Malta - Morocco - Singapore - Spain - Sweden - Switzerland - United Kingdom - U.S.A.

<http://www.st.com>