



HESTORE.HU

elektronikai alkatrész áruház

EN: This Datasheet is presented by the manufacturer.

Please visit our website for pricing and availability at www.hestore.hu.

Silicon NPN Power Transistors

BU2525DF

DESCRIPTION

- With TO-3PFa package
- High voltage
- High speed switching
- Built-in damper diode

APPLICATIONS

- For use in horizontal deflection circuits of large screen colour TV receivers

PINNING

PIN	DESCRIPTION
1	Base
2	Collector
3	Emitter

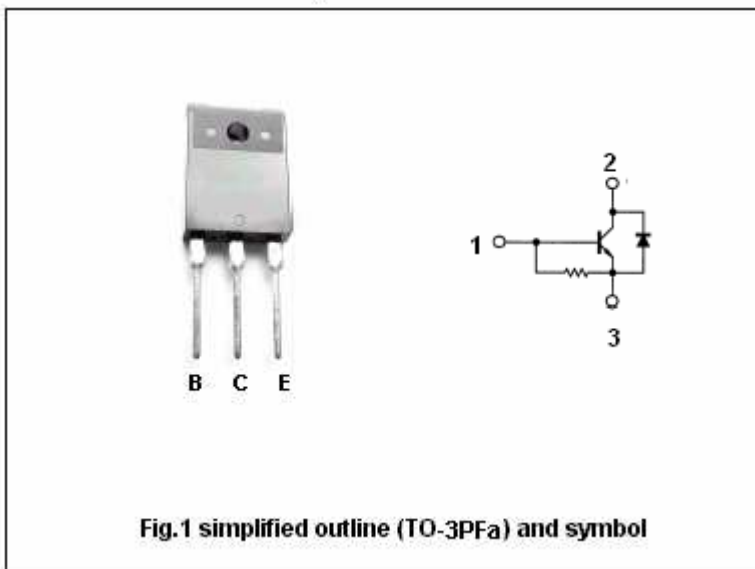

Fig.1 simplified outline (TO-3PFa) and symbol

Absolute maximum ratings(Ta=25°C)

SYMBOL	PARAMETER	CONDITIONS	VALUE	UNIT
V _{CBO}	Collector-base voltage	Open emitter	1500	V
V _{CEO}	Collector-emitter voltage	Open base	800	V
V _{EBO}	Emitter-base voltage	Open collector	7.5	A
I _C	Collector current (DC)		12	A
I _{CM}	Collector current -peak		30	A
I _B	Base Collector current (DC)		8	A
I _{BM}	Base current -peak		12	A
P _{tot}	Total power dissipation	T _C =25°C	45	W
T _j	Junction temperature		150	°C
T _{stg}	Storage temperature		-65~150	°C

Silicon NPN Power Transistors

BU2525DF

CHARACTERISTICS

T_j=25°C unless otherwise specified

SYMBOL	PARAMETER	CONDITIONS	MIN	TYP.	MAX	UNIT
V _{CEO(SUS)}	Collector-emitter sustaining voltage	I _C =100mA ; I _B =0, L=25mH	800			V
V _{(BR)EBO}	Emitter-base breakdown voltage	I _E =600mA ; I _C =0	7.5	13.5		V
V _{CEsat}	Collector-emitter saturation voltage	I _C =8A ; I _B =1.6 A			5.0	V
V _{BEsat}	Base-emitter saturation voltage	I _C =8A ; I _B =1.6 A			1.1	V
I _{CES}	Collector cut-off current	V _{CE} =BV _{CEs} ; V _{BE} =0 T _j =125°C			1.0 2.0	mA
I _{EBO}	Emitter cut-off current	V _{EB} =6V; I _C =0	72	110	218	mA
h _{FE-1}	DC current gain	I _C =1.0A ; V _{CE} =5V		11		
h _{FE-2}	DC current gain	I _C =8A ; V _{CE} =5V	5	7	9.5	
V _F	Diode forward voltage	I _F =8A		1.6	2.0	V
C _C	Collector capacitance	I _E =0, f=1MHz; V _{CB} =10V		145		pF

Silicon NPN Power Transistors

BU2525DF

PACKAGE OUTLINE

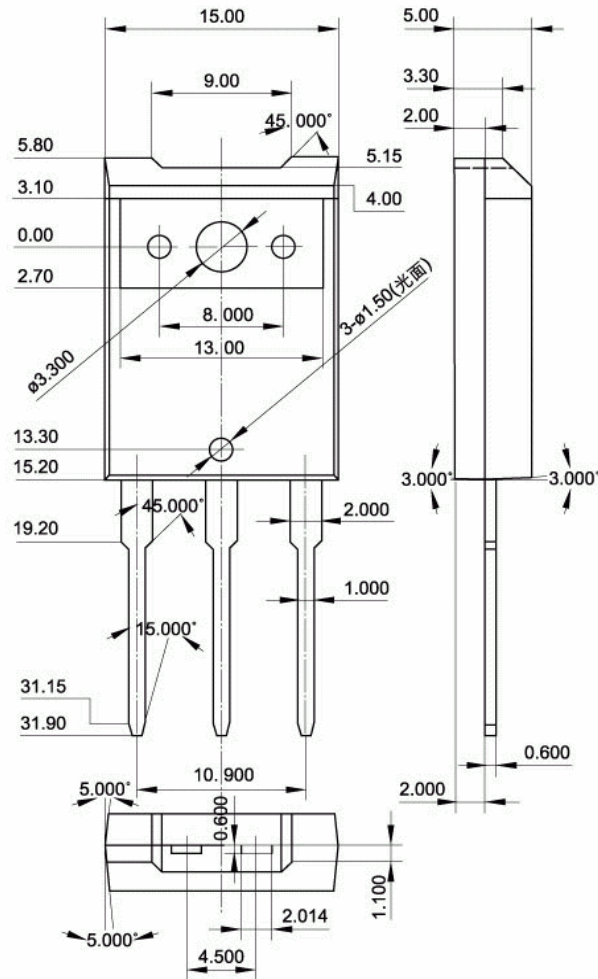

Fig.2 Outline dimensions (unindicated tolerance:±0.30mm)