



**HESTORE.HU**

elektronikai alkatrész áruház

**EN:** This Datasheet is presented by the manufacturer.

Please visit our website for pricing and availability at [www.hestore.hu](http://www.hestore.hu).

**1.2W AUDIO AMPLIFIER**

**DESCRIPTION**

The TBA820M is a monolithic integrated audio amplifier in a 8 lead dual in-line plastic package. It is intended for use as low frequency class B power amplifier with wide range of supply voltage: 3 to 16V, in portable radios, cassette recorders and players etc. Main features are: minimum working supply voltage of 3V, low quiescent current, low number of external components, good ripple rejection, no cross-over distortion, low power dissipation.

Output power:  $P_o = 2W$  at  $12V/8\Omega$ ,  $1.6W$  at  $9V/4\Omega$  and  $1.2W$  at  $9V/8\Omega$ .

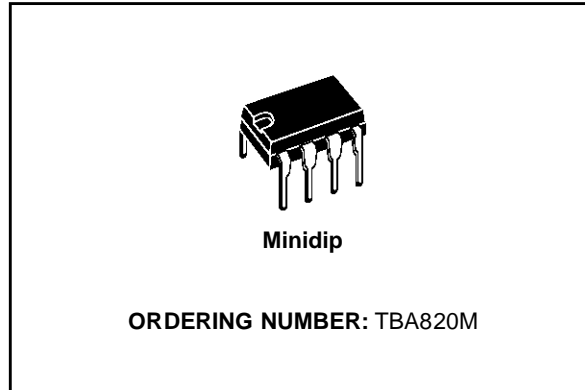

**ABSOLUTE MAXIMUM RATINGS**

Symbol	Parameter	Value	Unit
$V_s$	Supply voltage	16	V
$I_o$	Output peak current	1.5	A
$P_{tot}$	Power dissipation at $T_{amb} = 50^\circ C$	1	W
$T_{stg}, T_j$	Storage and junction temperature	-40 to 150	$^\circ C$

**TEST AND APPLICATION CIRCUITS**

**Figure 1. Circuit diagram with load connected to the supply voltage**

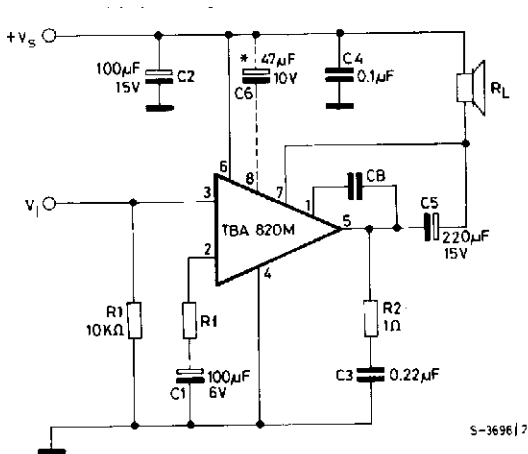

**Figure 2. Circuit diagram with load connected to ground**

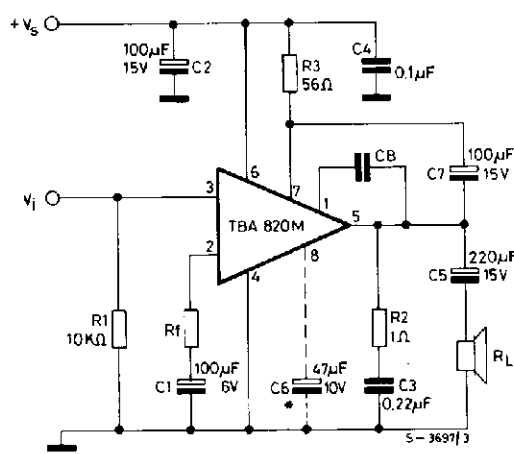

\* Capacitor C6 must be used when high ripple rejection is requested.

# TBA820M

## PIN CONNECTION (top view)

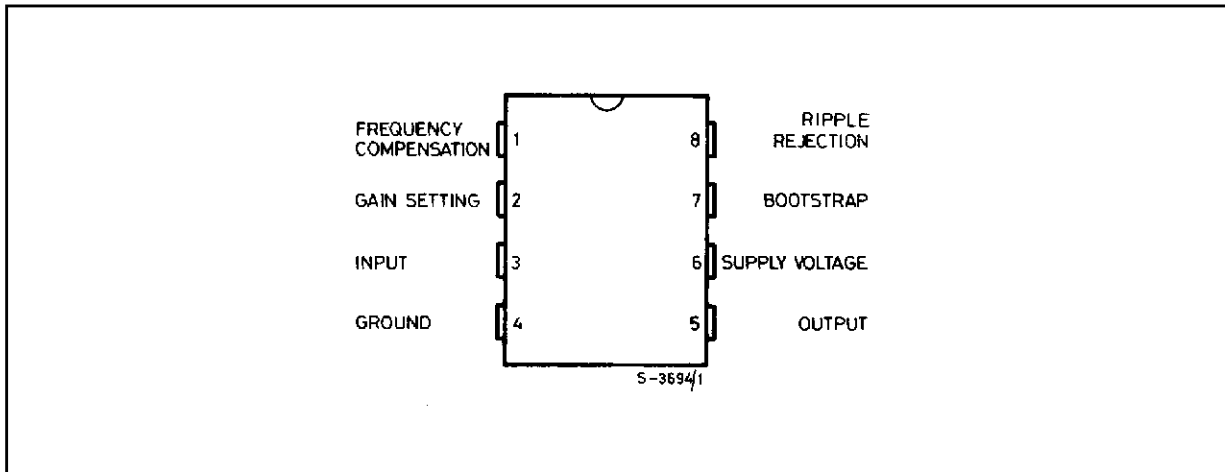

## SCHEMATIC DIAGRAM

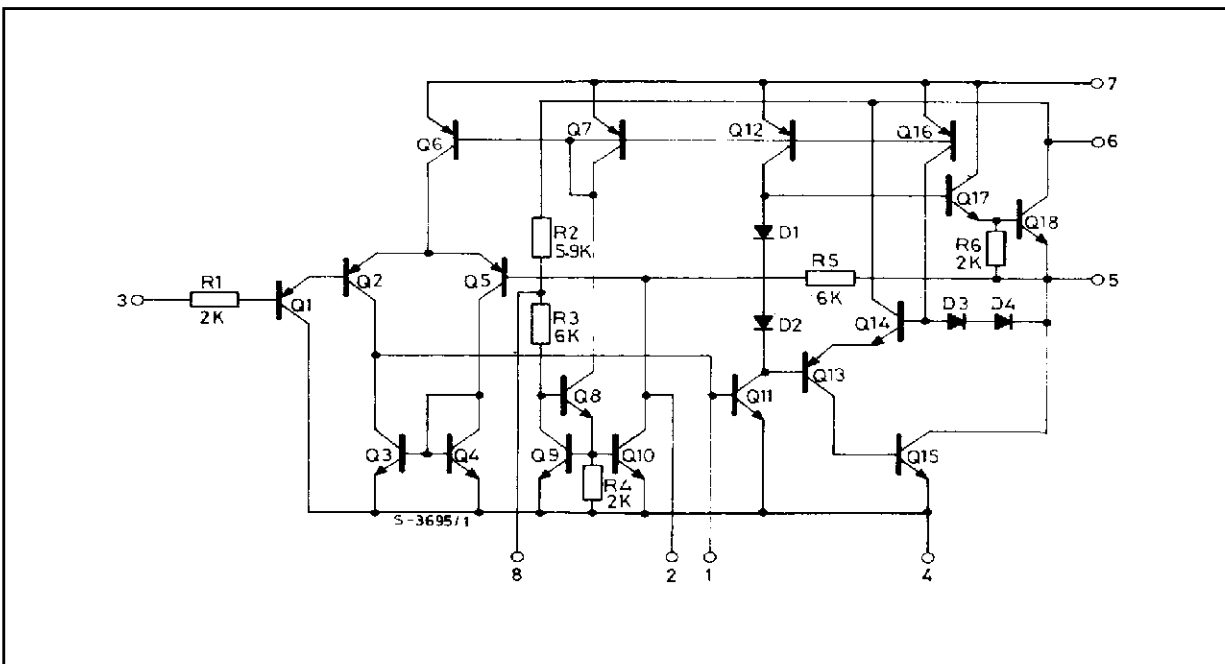

## THERMAL DATA

Symbol	Parameter	Value	Unit
$R_{th-j-amb}$	Thermal resistance junction-ambient	max 100	°C/W

**ELECTRICAL CHARACTERISTICS** (Refer to the test circuits  $V_s = 9V$ ,  $T_{amb} = 25\text{ }^\circ\text{C}$  unless otherwise specified)

Symbol	Parameter	Test conditions	Min.	Typ.	Max.	Unit
$V_s$	Supply voltage		3		16	V
$V_o$	Quiescent output voltage (pin 5)		4	4.5	5	V
$I_d$	Quiescent drain current			4	12	mA
$I_b$	Bias current (pin 3)			0.1		$\mu\text{A}$
$P_o$	Output power	$d = 10\%$ $f = 1\text{ kHz}$ $R_f = 120\Omega$ $V_s = 12V$ $R_L = 8\Omega$ $V_s = 9V$ $R_L = 4\Omega$ $V_s = 9V$ $R_L = 8\Omega$ $V_s = 6V$ $R_L = 4\Omega$ $V_s = 3.5V$ $R_L = 4\Omega$	0.9	2 1.6 1.2 0.75 0.25		W W W W W
$R_i$	Input resistance (pin 3)	$f = 1\text{ kHz}$		5		$\text{M}\Omega$
$B$	Frequency response (-3 dB)	$R_L = 8\Omega$ $C_B = 680\text{ pF}$ $C_5 = 1000\text{ }\mu\text{F}$ $R_f = 120\Omega$		25 to 7,000		Hz
				25 to 20,000		
$d$	Distortion	$P_o = 500\text{ mW}$ $R_L = 8\Omega$ $f = 1\text{ kHz}$	$R_f = 33\Omega$ $R_f = 120\Omega$	0.8 0.4		%
$G_v$	Voltage gain (open loop)	$f = 1\text{ kHz}$ $R_L = 8\Omega$		75		dB
$G_v$	Voltage gain (closed loop)	$R_L = 8\Omega$ $R_f = 33\Omega$ $f = 1\text{ kHz}$ $R_f = 120\Omega$		45 34		dB
$e_N$	Input noise voltage (*)			3		$\mu\text{V}$
$i_N$	Input noise current (*)			0.4		nA
$\frac{S+N}{N}$	Signal to noise ratio (*)	$P_o = 1.2W$ $R_L = 8\Omega$ $G_v = 34\text{ dB}$	$R_1 = 10K\Omega$ $R_1 = 50\text{ k}\Omega$	80 70		dB
SVR	Supply voltage rejection (test circuit of fig. 2)	$R_L = 8\Omega$ $f_{(ripple)} = 100\text{ Hz}$ $C_6 = 47\text{ }\mu\text{F}$ $R_f = 120\Omega$		42		dB

(\*) B = 22 Hz to 22 KHz

Figure 3. Output power vs. supply voltage

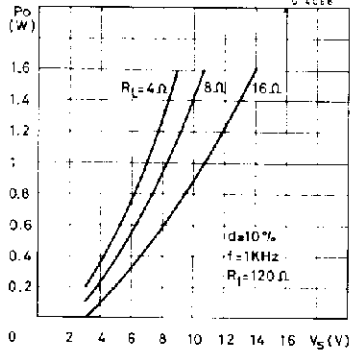

Figure 4. Harmonic distortion vs. output power

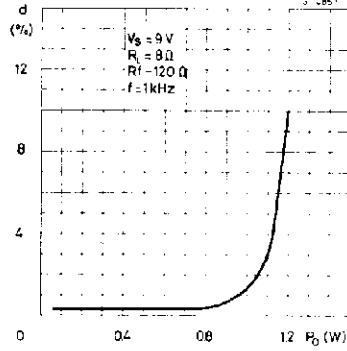

Figure 5. Power dissipation and efficiency vs. output power

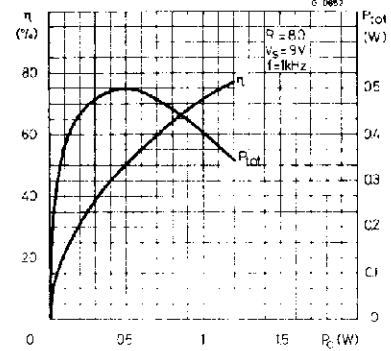

Figure 6. Maximum power dissipation (sine wave operation)

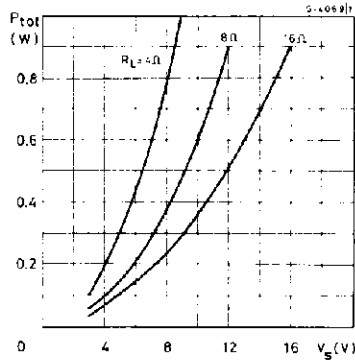

Figure 7. Suggested value of CB vs. Rf

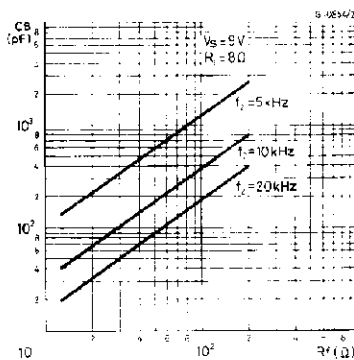

Figure 8. Frequency response

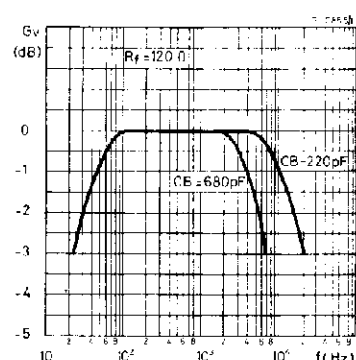

Figure 9. Harmonic distortion vs. frequency

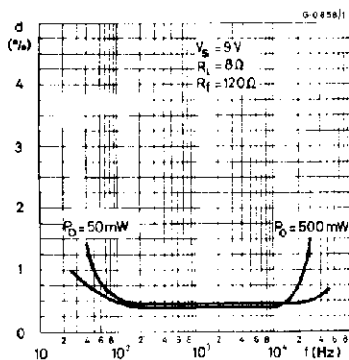

Figure 10. Supply voltage rejection (Fig. 2 circuit)

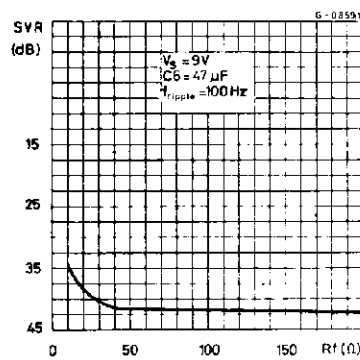
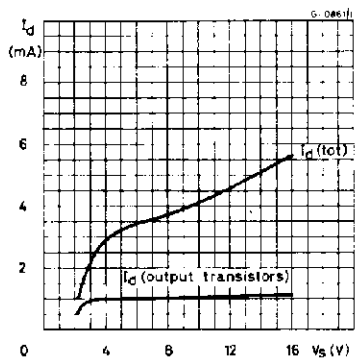
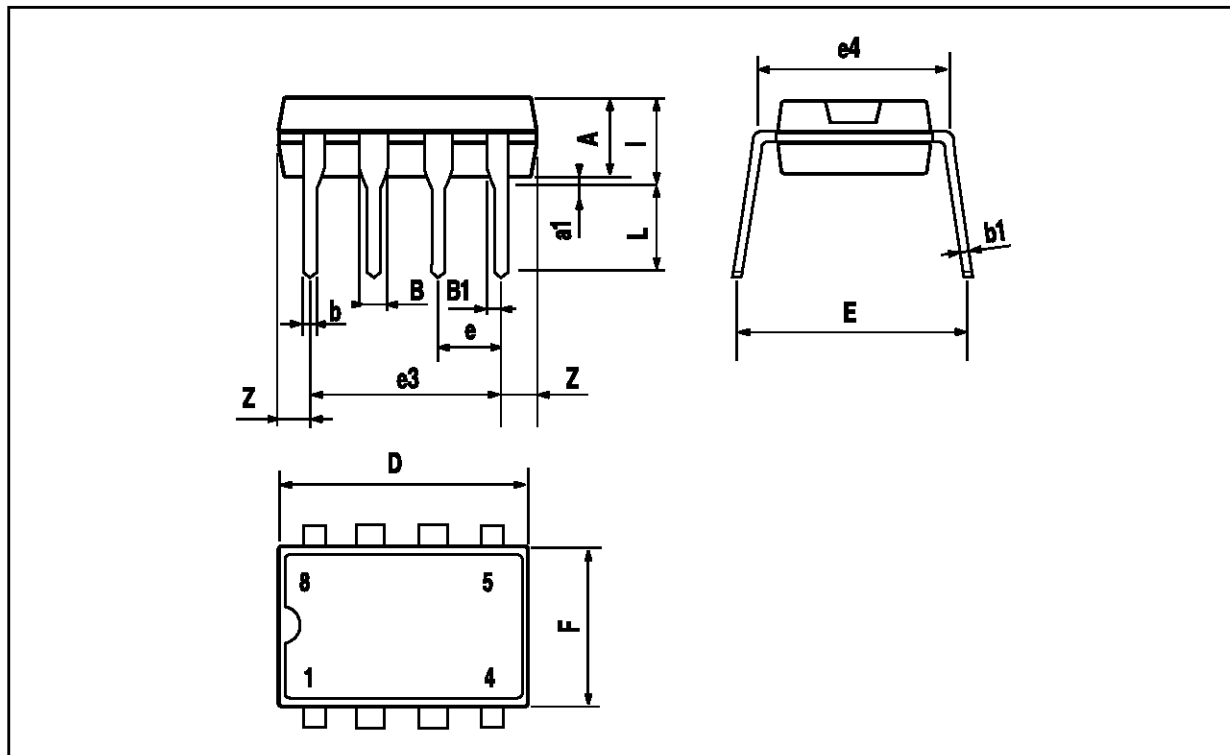

Figure 11. Quiescent current vs. supply voltage



MINIDIP PACKAGE MECHANICAL DATA

DIM.	mm			inch		
	MIN.	TYP.	MAX.	MIN.	TYP.	MAX.
A		3.32			0.131	
a1	0.51			0.020		
B	1.15		1.65	0.045		0.065
b	0.356		0.55	0.014		0.022
b1	0.204		0.304	0.008		0.012
D			10.92			0.430
E	7.95		9.75	0.313		0.384
e		2.54			0.100	
e3		7.62			0.300	
e4		7.62			0.300	
F			6.6			0.260
I			5.08			0.200
L	3.18		3.81	0.125		0.150
Z			1.52			0.060



Information furnished is believed to be accurate and reliable. However, SGS-THOMSON Microelectronics assumes no responsibility for the consequences of use of such information nor for any infringement of patents or other rights of third parties which may result from its use. No license is granted by implication or otherwise under any patent or patent rights of SGS-THOMSON Microelectronics. Specifications mentioned in this publication are subject to change without notice. This publication supersedes and replaces all information previously supplied. SGS-THOMSON Microelectronics products are not authorized for use as critical components in life support devices or systems without express written approval of SGS-THOMSON Microelectronics.

© 1994 SGS-THOMSON Microelectronics - All Rights Reserved

SGS-THOMSON Microelectronics GROUP OF COMPANIES

Australia - Brazil - France - Germany - Hong Kong - Italy - Japan - Korea - Malaysia - Malta - Morocco - The Netherlands - Singapore - Spain - Sweden - Switzerland - Taiwan - Thailand - United Kingdom - U.S.A.