



HESTORE.HU

elektronikai alkatrész áruház

EN: This Datasheet is presented by the manufacturer.

Please visit our website for pricing and availability at www.hestore.hu.

500mA, Low Dropout, Low Noise Ultra-Fast Without Bypass Capacitor CMOS LDO Regulator

General Description

The RT9013 is a high-performance, 500mA LDO regulator, offering extremely high PSRR and ultra-low dropout. Ideal for portable RF and wireless applications with demanding performance and space requirements.

The RT9013 quiescent current as low as 25µA, further prolonging the battery life. The RT9013 also works with low-ESR ceramic capacitors, reducing the amount of board space necessary for power applications, critical in hand-held wireless devices.

The RT9013 consumes typical 0.7µA in shutdown mode and has fast turn-on time less than 40µs. The other features include ultra-low dropout voltage, high output accuracy, current limiting protection, and high ripple rejection ratio. Available in the SC-82, SOT-23-5, SC-70-5 and WDFN-6L 2x2 package.

Ordering Information

RT9013-□□□	Package Type
	Y : SC-82
	B : SOT-23-5
	U5 : SC-70-5
	QW : WDFN-6L 2x2 (W-Type)
	Lead Plating System
	P : Pb Free
	G : Green (Halogen Free and Pb Free)
	Fixed Output Voltage
	12 : 1.2V
	13 : 1.3V
	15 : 1.5V
	16 : 1.6V
	:
	32 : 3.2V
	33 : 3.3V
	1B : 1.25V
	1H : 1.85V
	2H : 2.85V

Note :

Richtek products are :

- ▶ RoHS compliant and compatible with the current requirements of IPC/JEDEC J-STD-020.
- ▶ Suitable for use in SnPb or Pb-free soldering processes.

Features

- Wide Operating Voltage Ranges : 2.2V to 5.5V
- Low Dropout : 250mV at 500mA
- Ultra-Low-Noise for RF Application
- Ultra-Fast Response in Line/Load Transient
- Current Limiting Protection
- Thermal Shutdown Protection
- High Power Supply Rejection Ratio
- Output Only 1µF Capacitor Required for Stability
- TTL-Logic-Controlled Shutdown Input
- RoHS Compliant and 100% Lead (Pb)-Free

Applications

- CDMA/GSM Cellular Handsets
- Portable Information Appliances
- Laptop, Palmtops, Notebook Computers
- Hand-Held Instruments
- Mini PCI & PCI-Express Cards
- PCMCIA & New Cards

Marking Information

For marking information, contact our sales representative directly or through a Richtek distributor located in your area.

Pin Configurations

(TOP VIEW)

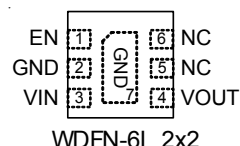
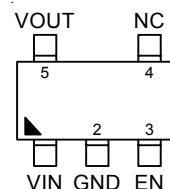
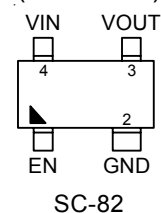

Typical Application Circuit

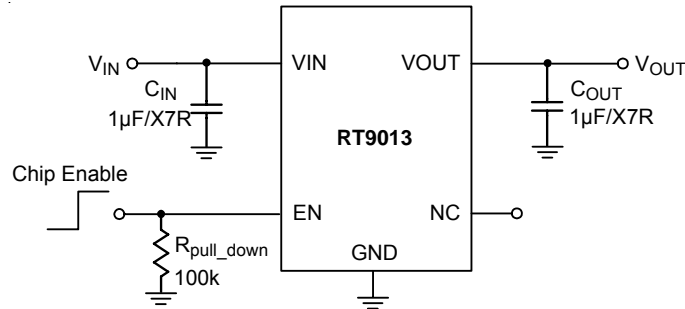

Functional Pin Description

Pin Number			Pin Name	Pin Function
SC-82	SOT-23-5 / SC-70-5	WDFN-6L 2x2		
3	5	4	VOUT	Regulator Output.
--	4	5, 6	NC	No Internal Connection.
2	2	2, 7 (Exposed Pad)	GND	Common Ground. The exposed pad must be soldered to a large PCB and connected to GND for maximum power dissipation.
1	3	1	EN	Enable Input Logic, Active High. When the EN goes to a logic low, the device will be shutdown mode.
4	1	3	VIN	Supply Input.

Function Block Diagram

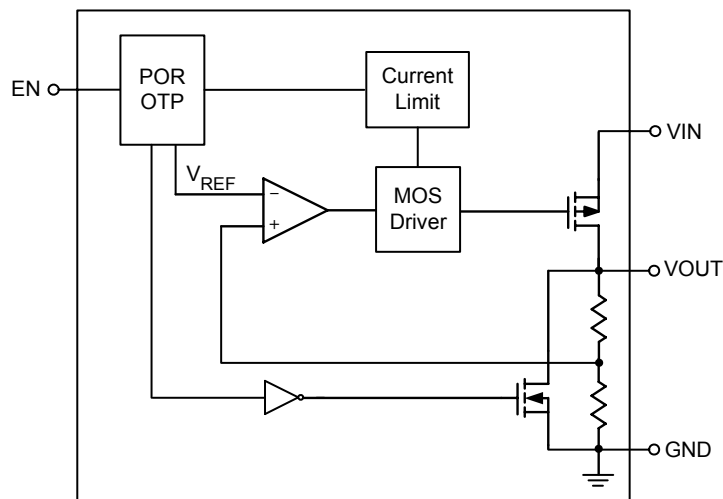

Absolute Maximum Ratings (Note 1)

- Supply Input Voltage ----- 6V
- EN Input Voltage ----- 6V
- Power Dissipation, P_D @ T_A = 25°C
 - SOT-23-5 ----- 0.4W
 - SC-70-5/ SC-82 ----- 0.3W
 - WDFN-6L 2x2 ----- 0.606W
- Package Thermal Resistance (Note 2)
 - SOT-23-5, θ_{JA} ----- 250°C/W
 - SOT-23-5, θ_{JC} ----- 25°C/W
 - SC-70-5/ SC-82, θ_{JA} ----- 333°C/W
 - WDFN-6L 2x2, θ_{JA} ----- 165°C/W
 - WDFN-6L 2x2, θ_{JC} ----- 20°C/W
- Lead Temperature (Soldering, 10 sec.) ----- 260°C
- Junction Temperature ----- 150°C
- Storage Temperature Range ----- -65°C to 150°C
- ESD Susceptibility (Note 3)
 - HBM ----- 2kV
 - MM ----- 200V

Recommended Operating Conditions (Note 4)

- Supply Input Voltage ----- 2.2V to 5.5V
- Junction Temperature Range ----- -40°C to 125°C
- Ambient Temperature Range ----- -40°C to 85°C

Electrical Characteristics

(V_{IN} = V_{OUT} + 0.5V, V_{EN} = V_{IN}, C_{IN} = C_{OUT} = 1μF (Ceramic, X7R), T_A = 25°C unless otherwise specified)

Parameter	Symbol	Test Conditions	Min	Typ	Max	Unit
Input Voltage Range	V _{IN}		2.2	--	5.5	V
Output Noise Voltage	V _{ON}	V _{OUT} = 1.5V, C _{OUT} = 1μF, I _{OUT} = 0mA	--	30	--	μV _{RMS}
Output Voltage Accuracy (Fixed Output Voltage)	ΔV _{OUT}	I _{OUT} = 10mA	-2	0	+2	%
Quiescent Current (Note 5)	I _Q	V _{EN} = 5V, I _{OUT} = 0mA	--	25	50	μA
Shutdown Current	I _{SHDN}	V _{EN} = 0V	--	0.7	1.5	μA
Current Limit	I _{LIM}	R _{LOAD} = 0Ω, 2.2V ≤ V _{IN} < 2.6V	0.4	0.5	0.85	A
		R _{LOAD} = 0Ω, 2.7V ≤ V _{IN} ≤ 5.5V	0.5	0.6	0.85	A
Dropout Voltage (Note 6)	V _{DROP}	I _{OUT} = 400mA, 2.2V ≤ V _{IN} < 2.7V	--	160	320	mV
		I _{OUT} = 500mA, 2.7V ≤ V _{IN} ≤ 5.5V	--	250	400	
Load Regulation (Note 7) (Fixed Output Voltage)	ΔV _{LOAD}	1mA < I _{OUT} < 400mA 2.2V ≤ V _{IN} < 2.7V	--	--	0.6	%
		1mA < I _{OUT} < 500mA 2.7V ≤ V _{IN} ≤ 5.5V	--	--	1	

To be continued

Parameter		Symbol	Test Conditions	Min	Typ	Max	Unit
EN Threshold Voltage	Logic-Low	V_{IL}		0	--	0.6	V
	Logic-High	V_{IH}		1.6	--	5.5	
Enable Pin Current		I_{EN}		--	0.1	1	μA
Power Supply Rejection Rate		PSRR	$I_{OUT} = 100mA, f = 10kHz$	--	-50	--	dB
Line Regulation		ΔV_{LINE}	$V_{IN} = (V_{OUT} + 0.5) \text{ to } 5.5V,$ $I_{OUT} = 1mA$	--	0.01	0.2	%/V
Thermal Shutdown Temperature		T_{SD}		--	170	--	$^{\circ}C$
Thermal Shutdown Hysteresis		ΔT_{SD}		--	30	--	

Note 1. Stresses listed as the above “Absolute Maximum Ratings” may cause permanent damage to the device. These are for stress ratings. Functional operation of the device at these or any other conditions beyond those indicated in the operational sections of the specifications is not implied. Exposure to absolute maximum rating conditions for extended periods may remain possibility to affect device reliability.

Note 2. θ_{JA} is measured in the natural convection at $T_A = 25^{\circ}C$ on a low effective thermal conductivity test board of JEDEC 51-3 thermal measurement standard. The case position of θ_{JC} is on the exposed pad for the package.

Note 3. Devices are ESD sensitive. Handling precaution is recommended.

Note 4. The device is not guaranteed to function outside its operating conditions.

Note 5. Quiescent, or ground current, is the difference between input and output currents. It is defined by $I_Q = I_{IN} - I_{OUT}$ under no load condition ($I_{OUT} = 0mA$). The total current drawn from the supply is the sum of the load current plus the ground pin current.

Note 6. The dropout voltage is defined as $V_{IN} - V_{OUT}$, which is measured when V_{OUT} is $V_{OUT(NORMAL)} - 100mV$.

Note 7. Regulation is measured at constant junction temperature by using a 2ms current pulse. Devices are tested for load regulation in the load range from 10mA to 500mA.

Typical Operating Characteristics

($C_{IN} = C_{OUT} = 1\mu/X7R$, unless otherwise specified)

Output Voltage vs. Temperature

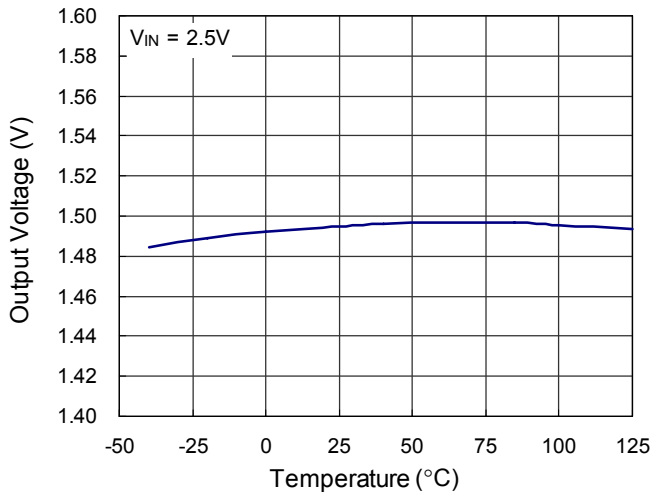

Quiescent Current vs. Temperature

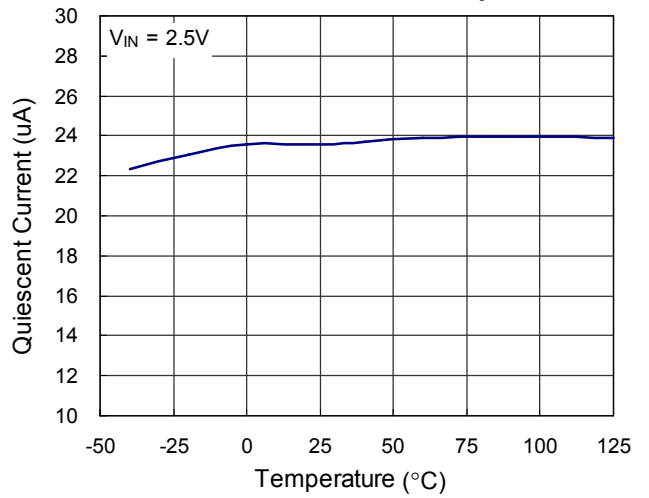

Dropout Voltage vs. Load Current

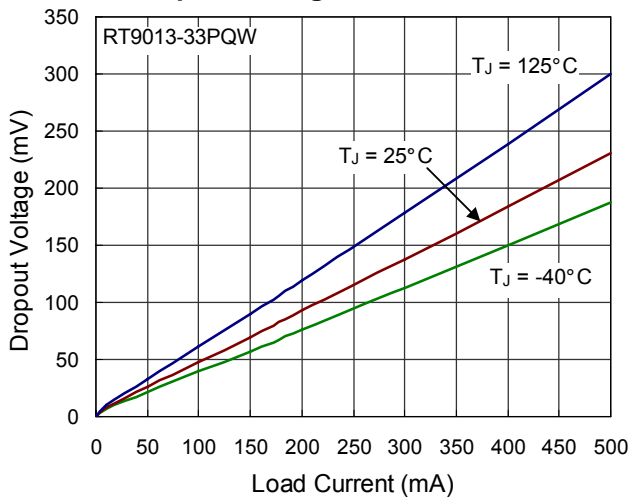

Dropout Voltage vs. Load Current

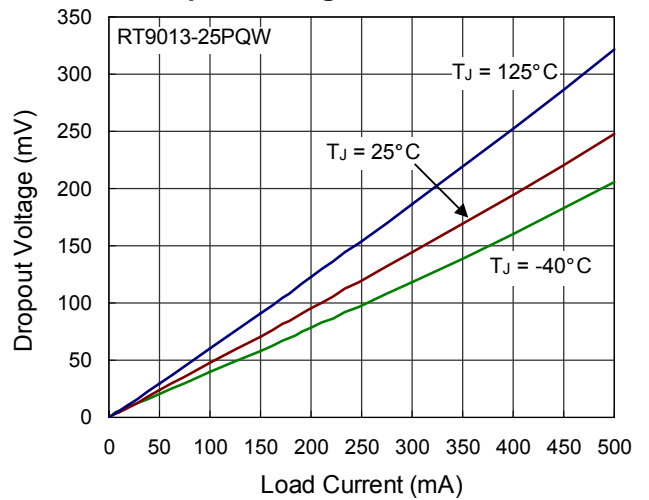

EN Pin Shutdown Response

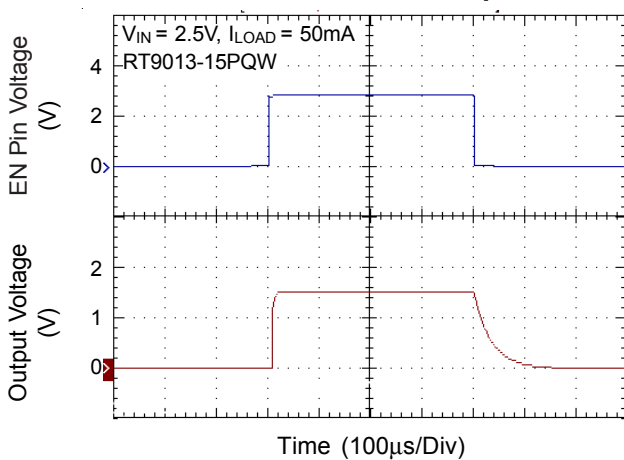

Start Up

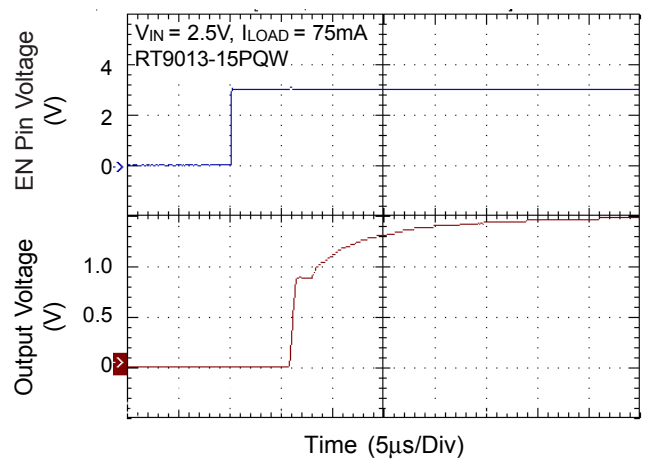

Line Transient Response

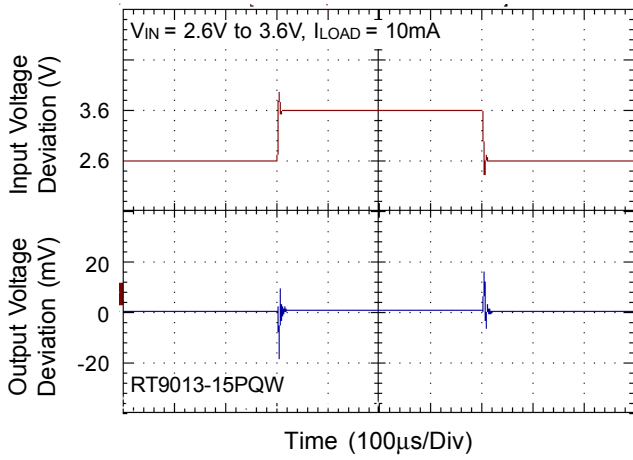

Line Transient Response

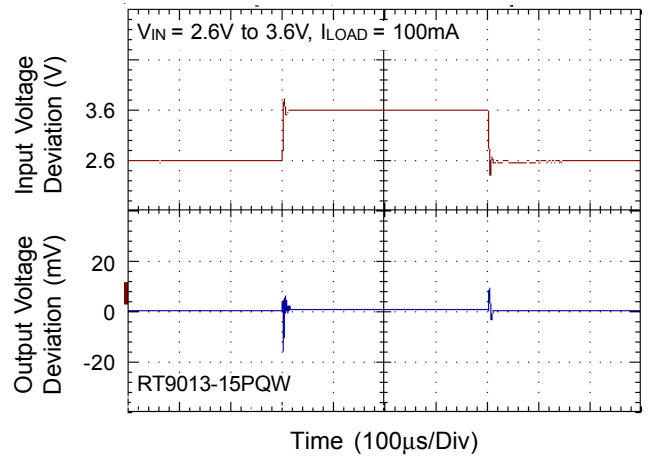

Load Transient Response

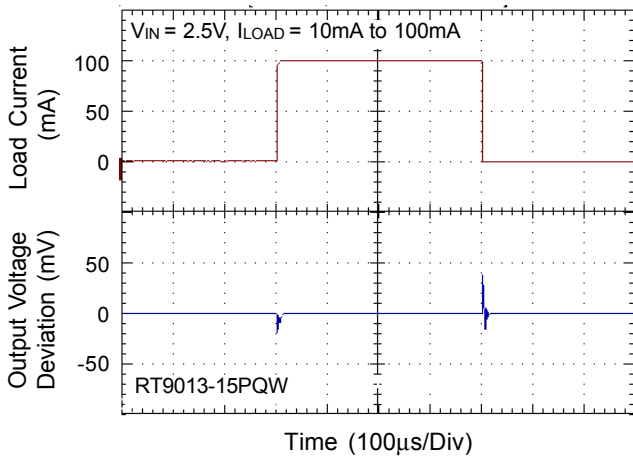

Load Transient Response

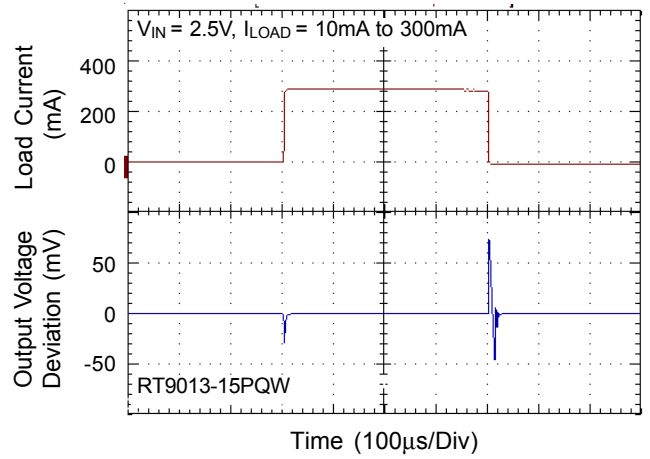

Noise

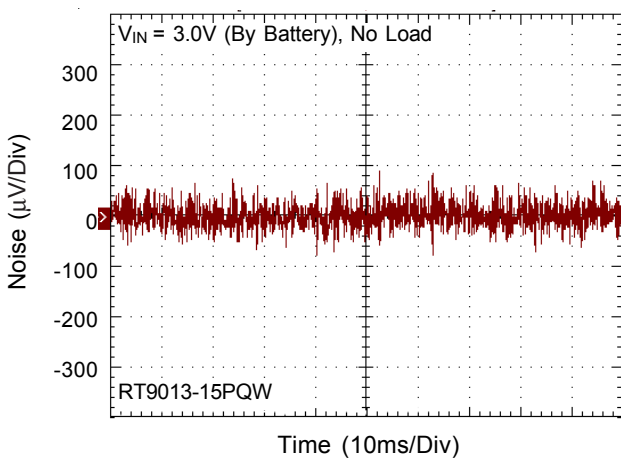

Noise

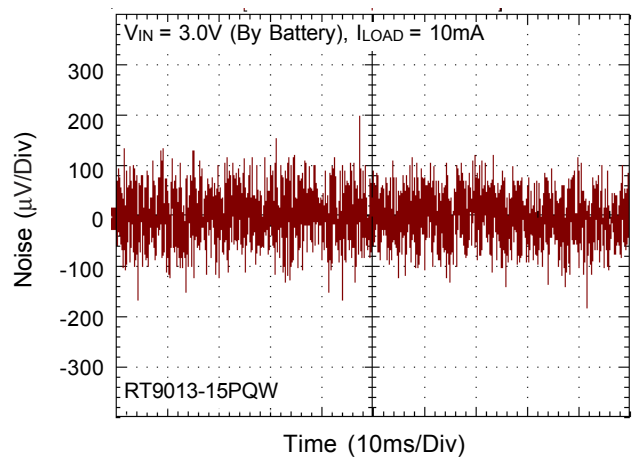

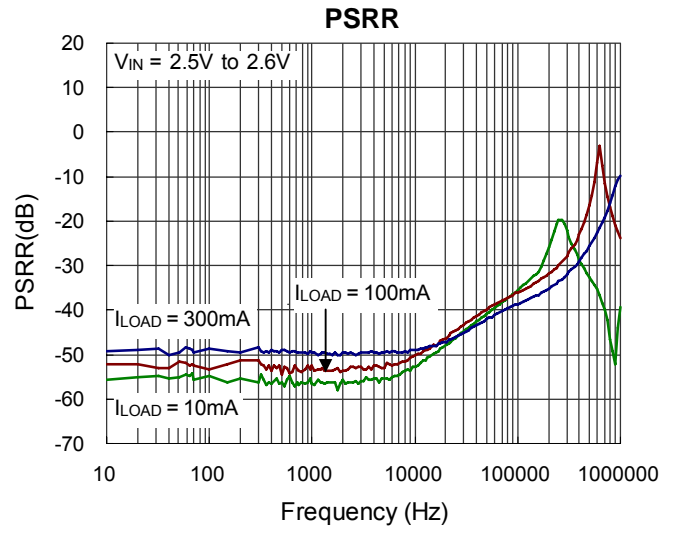
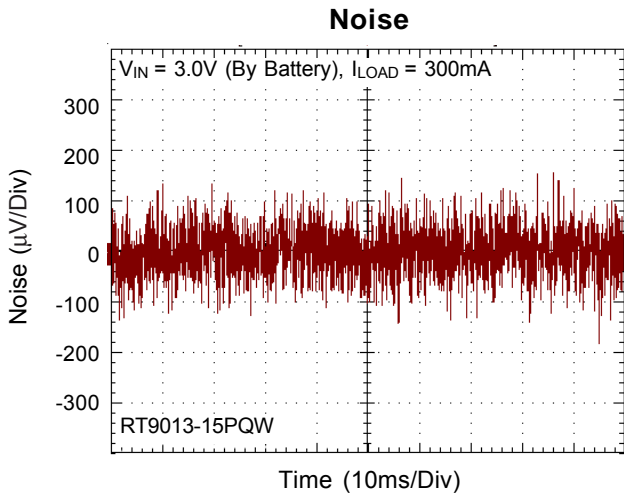

Applications Information

Like any low-dropout regulator, the external capacitors used with the RT9013 must be carefully selected for regulator stability and performance. Using a capacitor whose value is $> 1\mu\text{F}/X7\text{R}$ on the RT9013 input and the amount of capacitance can be increased without limit. The input capacitor must be located a distance of not more than 0.5 inch from the input pin of the IC and returned to a clean analog ground. Any good quality ceramic can be used for this capacitor. The capacitor with larger value and lower ESR (equivalent series resistance) provides better PSRR and line-transient response.

The output capacitor must meet both requirements for minimum amount of capacitance and ESR in all LDOs application. The RT9013 is designed specifically to work with low ESR ceramic output capacitor in space-saving and performance consideration. Using a ceramic capacitor whose value is at least $1\mu\text{F}$ with ESR is $> 5\text{m}\Omega$ on the RT9013 output ensures stability. The RT9013 still works well with output capacitor of other types due to the wide stable ESR range. Figure 1. shows the curves of allowable ESR range as a function of load current for various output capacitor values. Output capacitor of larger capacitance can reduce noise and improve load transient response, stability, and PSRR. The output capacitor should be located not more than 0.5 inch from the VOUT pin of the RT9013 and returned to a clean analog ground.

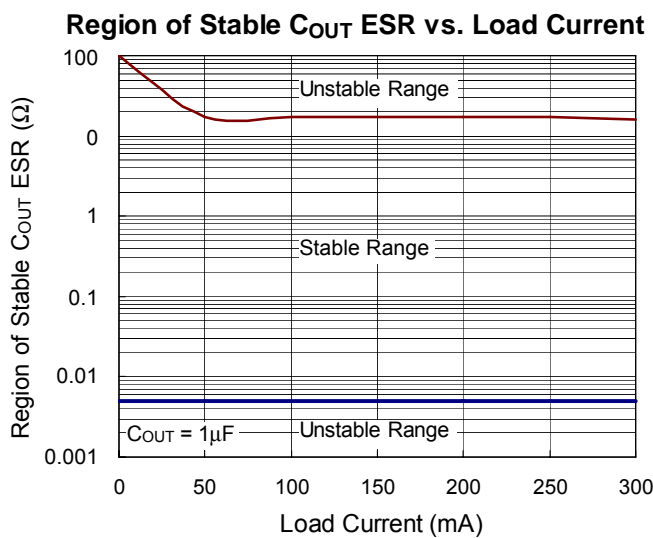

Figure 1

Enable

The RT9013 goes into sleep mode when the EN pin is in a logic low condition. During this condition, the RT9013 has an EN pin to turn on or turn off regulator, When the EN pin is logic high, the regulator will be turned on. The supply current to $0.7\mu\text{A}$ typical. The EN pin may be directly tied to V_{IN} to keep the part on. The Enable input is CMOS logic and cannot be left floating.

PSRR

The power supply rejection ratio (PSRR) is defined as the gain from the input to output divided by the gain from the supply to the output. The PSRR is found to be

$$\text{PSRR} = 20 \times \log\left(\frac{\Delta\text{Gain Error}}{\Delta\text{Supply}}\right)$$

Note that when heavy load measuring, Δsupply will cause $\Delta\text{temperature}$. And $\Delta\text{temperature}$ will cause $\Delta\text{output voltage}$. So the heavy load PSRR measuring is include temperature effect.

Current limit

The RT9013 contains an independent current limiter, which monitors and controls the pass transistor's gate voltage, limiting the output current to 0.6A (typ.). The output can be shorted to ground indefinitely without damaging the part.

Thermal Considerations

Thermal protection limits power dissipation in RT9013. When the operation junction temperature exceeds 170°C , the OTP circuit starts the thermal shutdown function and turns the pass element off. The pass element turn on again after the junction temperature cools by 30°C .

For continuous operation, do not exceed absolute maximum operation junction temperature 125°C . The power dissipation definition in device is :

$$P_D = (V_{\text{IN}} - V_{\text{OUT}}) \times I_{\text{OUT}} + V_{\text{IN}} \times I_Q$$

The maximum power dissipation depends on the thermal resistance of IC package, PCB layout, the rate of surroundings airflow and temperature difference between junction to ambient. The maximum power dissipation can be calculated by following formula :

$$P_{D(MAX)} = (T_{J(MAX)} - T_A) / \theta_{JA}$$

Where $T_{J(MAX)}$ is the maximum operation junction temperature, T_A is the ambient temperature and the θ_{JA} is the junction to ambient thermal resistance.

For recommended operating conditions specification of RT9013 the maximum junction temperature is 125°C and T_A is the operated ambient temperature. The junction to ambient thermal resistance θ_{JA} (θ_{JA} is layout dependent) for WDFN-6L 2x2 package is 165°C/W, SOT-23-5 package is 250°C/W and SC-70-5/ SC-82 package is 333°C/W on the standard JEDEC 51-3 single-layer thermal test board. The maximum power dissipation at $T_A = 25^\circ\text{C}$ can be calculated by following formula :

$$P_{D(MAX)} = (125^\circ\text{C} - 25^\circ\text{C}) / 165^\circ\text{C/W} = 0.606 \text{ W for WDFN-6L 2x2 packages}$$

$$P_{D(MAX)} = (125^\circ\text{C} - 25^\circ\text{C}) / 250^\circ\text{C/W} = 0.400 \text{ W for SOT-23-5 packages}$$

$$P_{D(MAX)} = (125^\circ\text{C} - 25^\circ\text{C}) / 333^\circ\text{C/W} = 0.300 \text{ W for SC-70-5/ SC-82 packages}$$

The maximum power dissipation depends on operating ambient temperature for fixed $T_{J(MAX)}$ and thermal resistance θ_{JA} . For RT9013 package, the Figure 2 of derating curves allows the designer to see the effect of rising ambient temperature on the maximum power dissipation allowed.

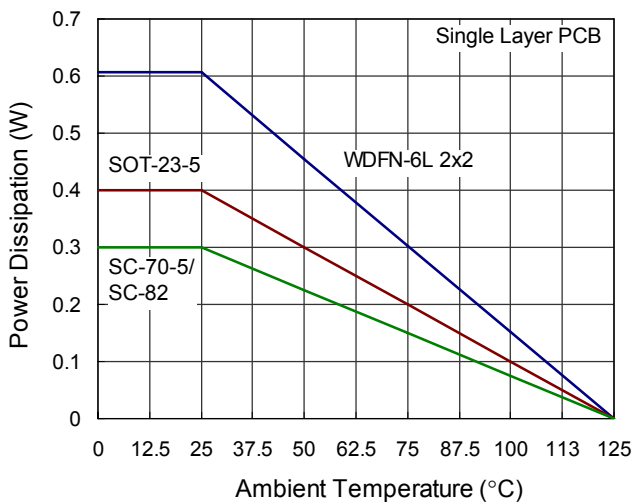
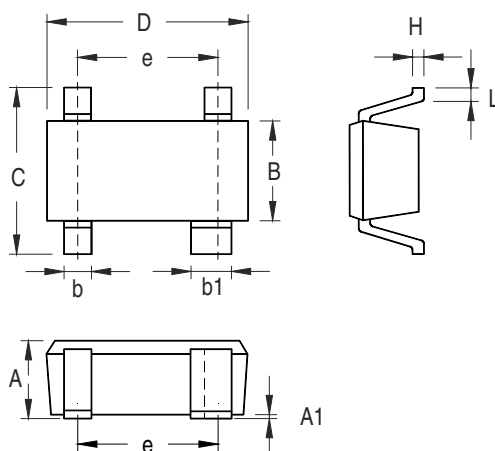

Figure 2. Derating Curves for RT9013 Packages

Outline Dimension



Symbol	Dimensions In Millimeters		Dimensions In Inches	
	Min	Max	Min	Max
A	0.800	1.100	0.031	0.043
A1	0.000	0.100	0.000	0.004
B	1.150	1.350	0.045	0.053
b	0.150	0.400	0.006	0.016
b1	0.350	0.500	0.014	0.020
C	1.800	2.450	0.071	0.096
D	1.800	2.200	0.071	0.087
e	1.300		0.051	
H	0.080	0.260	0.003	0.010
L	0.200	0.460	0.008	0.018

SC-82 Surface Mount Package

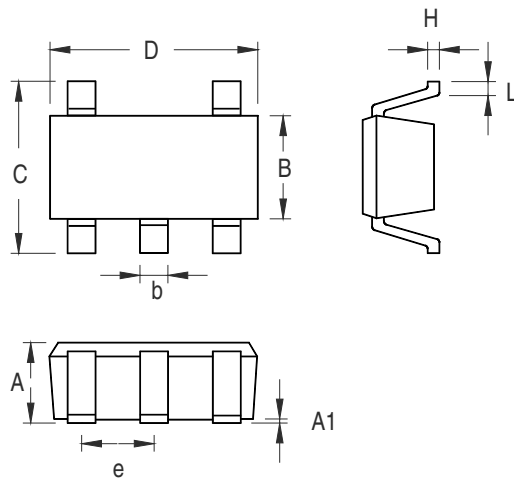

Symbol	Dimensions In Millimeters		Dimensions In Inches	
	Min	Max	Min	Max
A	0.889	1.295	0.035	0.051
A1	0.000	0.152	0.000	0.006
B	1.397	1.803	0.055	0.071
b	0.356	0.559	0.014	0.022
C	2.591	2.997	0.102	0.118
D	2.692	3.099	0.106	0.122
e	0.838	1.041	0.033	0.041
H	0.080	0.254	0.003	0.010
L	0.300	0.610	0.012	0.024

SOT-23-5 Surface Mount Package

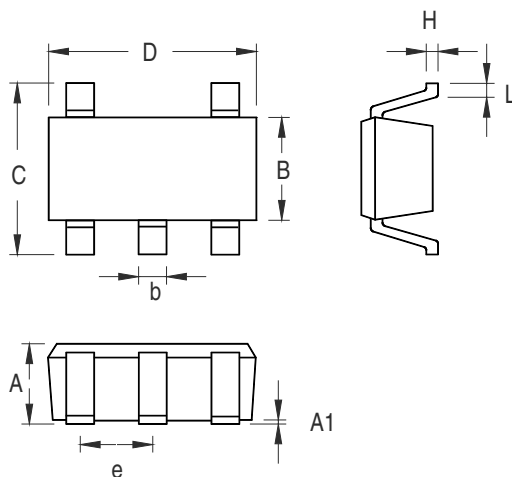

Symbol	Dimensions In Millimeters		Dimensions In Inches	
	Min	Max	Min	Max
A	0.800	1.100	0.031	0.044
A1	0.000	0.100	0.000	0.004
B	1.150	1.350	0.045	0.054
b	0.150	0.400	0.006	0.016
C	1.800	2.450	0.071	0.096
D	1.800	2.250	0.071	0.089
e	0.650		0.026	
H	0.080	0.260	0.003	0.010
L	0.210	0.460	0.008	0.018

SC-70-5 Surface Mount Package

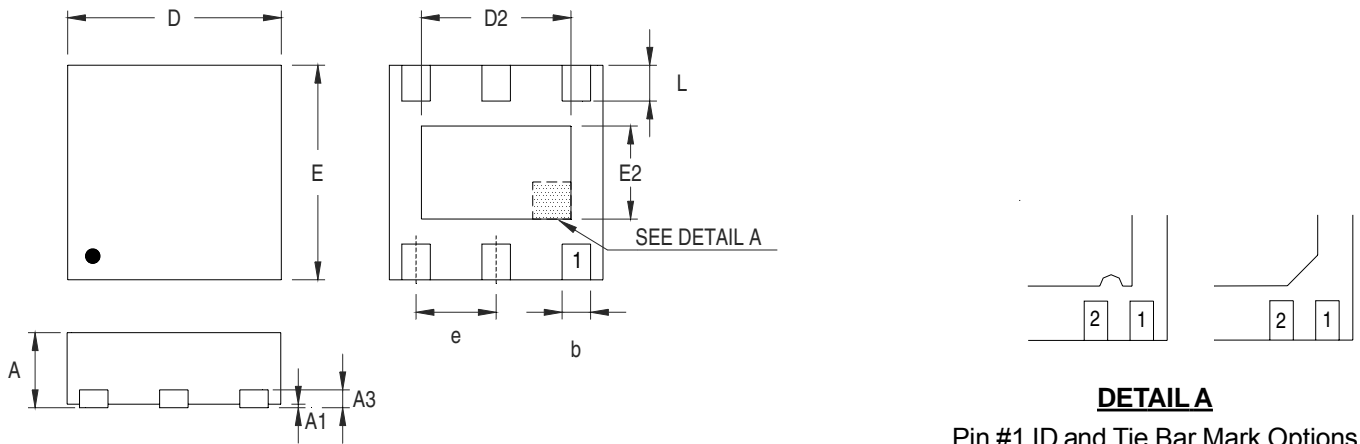

DETAIL A

Pin #1 ID and Tie Bar Mark Options

Note : The configuration of the Pin #1 identifier is optional, but must be located within the zone indicated.

Symbol	Dimensions In Millimeters		Dimensions In Inches	
	Min	Max	Min	Max
A	0.700	0.800	0.028	0.031
A1	0.000	0.050	0.000	0.002
A3	0.175	0.250	0.007	0.010
b	0.200	0.350	0.008	0.014
D	1.950	2.050	0.077	0.081
D2	1.000	1.450	0.039	0.057
E	1.950	2.050	0.077	0.081
E2	0.500	0.850	0.020	0.033
e	0.650		0.026	
L	0.300	0.400	0.012	0.016

W-Type 6L DFN 2x2 Package

Richtek Technology Corporation

Headquarter
 5F, No. 20, Taiyuen Street, Chupei City
 Hsinchu, Taiwan, R.O.C.
 Tel: (8863)5526789 Fax: (8863)5526611

Richtek Technology Corporation

Taipei Office (Marketing)
 5F, No. 95, Minchiuan Road, Hsintien City
 Taipei County, Taiwan, R.O.C.
 Tel: (8862)86672399 Fax: (8862)86672377
 Email: marketing@richtek.com

Information that is provided by Richtek Technology Corporation is believed to be accurate and reliable. Richtek reserves the right to make any change in circuit design, specification or other related things if necessary without notice at any time. No third party intellectual property infringement of the applications should be guaranteed by users when integrating Richtek products into any application. No legal responsibility for any said applications is assumed by Richtek.